

MM 1700-1
July, 1976

STANDARDIZED TEST PROCEDURE FOR MIDWAY'S PROCESSOR BOARDS



MIDWAY MFG. CO.

A BALLY COMPANY

**10750 WEST GRAND AVENUE
FRANKLIN PARK, ILLINOIS, 60131, U.S.A.**

PHONE: 312 451-1360

TOLL FREE NO.: 800 323-7182

CABLE ADDRESS: MIDCO

TELEX NO: 72-1596

FLOW CHART OF TROUBLESHOOTING
PROCEDURE

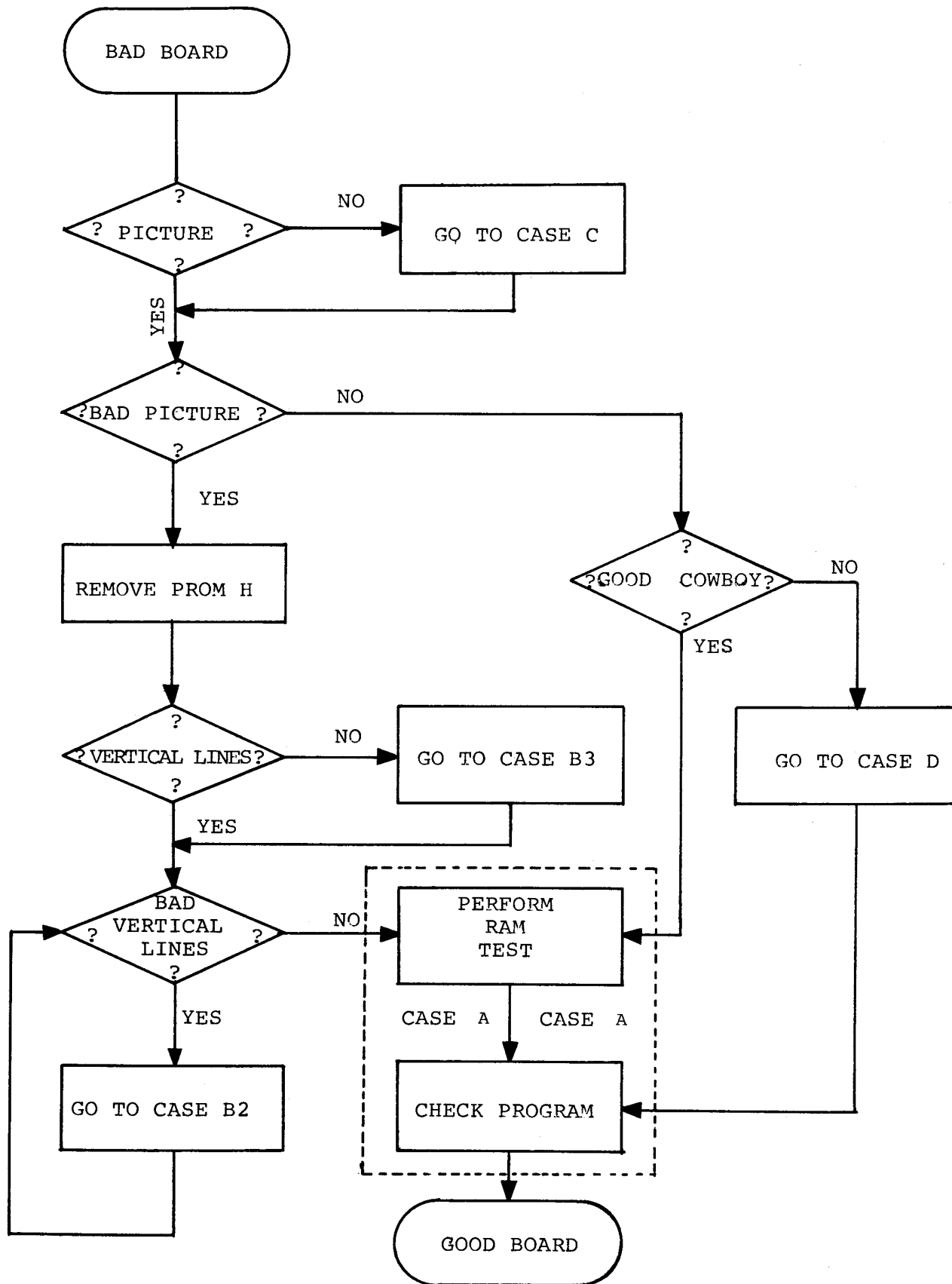

**STANDARDIZED
TEST PROCEDURE
FOR
MIDWAY'S
PROCESSOR BOARDS**

TABLE OF CONTENTS

	Flow Chart of Troubleshooting Procedure . . .	Inside Front Cover
ii	List of Illustrationsiii
1.	INTRODUCTION.1
2.	ASSUMPTIONS2
3.	TEST PROCEDURE.3
3.1	Preliminary Instructions3
3.2	Case A: Good Picture - Bad Program.5
3.3	Case B: Bad Picture7
3.3.1	Case B1: Good Vertical Lines7
	No Ram Test9
3.3.2	Case B2: Bad Vertical Lines.	15
3.3.3	Case B3: No Vertical Lines	23
3.4	Case C: No Picture - Dead	32
3.5	Case D: Bad Cowboy.	36
	Lines in Cowboy	37
	Sample.	39
4.	APPENDIX 1: Clock Section Check	40
	2: Some Useful Pin Configurations and Logic Diagrams.	44
	3: Mother Board Schematic.	46

LIST OF ILLUSTRATIONS

Figure #

3.2-1	Good Picture with Good Program5
	(a) Gunfight	
	(b) Sea Wolf	
3.3.1-1	Good Vertical Lines.7
3.3.1-2	Section showing PROMS and IC 7442.8
3.3.1-3	Section showing IC 74174's	10
3.3.1-4	Waveform at C3 PIN 2	11
3.3.1-5	Ram Address.	12
	(a) With Information	
	(b) Without Information	
3.3.2-1	Section showing Inputs to RAMS	14
3.3.2-2	Good Tri-State Data Input.	16
3.3.2-3	Good Ram Data Output	16
	(a) Tri-State	
	(b) Bi-State	

List of Illustrations

(cont.)

<u>Figure #</u>		
3.3.2-4	Good Address	18
3.3.2-5	Section showing Bidirectional Lines.	20
3.3.2-6	Input from Multiplexer to IC 8216.	19
3.3.2-7	Bidirectional Line	19
3.3.2-8	Clock at Pin 2 of Multiplexer IC 74153	21
3.3.2-9	Clock at Pin 14 of Multiplexer IC 74153.	21
3.3.3-1	Section showing Clock Driver Inputs and Outputs . .	24
3.3.3-2	Clock Driver IC 3245 Outputs	25
3.3.3-3	Flip Flop IC 74LS74 at E3.	26
3.3.3-4	Section showing Inputs and Outputs of IC 9322 at F4.	28
3.3.3-5	Sync, WR, and DBIN at CPU.	27
3.3.3-6	Ram Write Enable - Pin 12 of RAMS	29
3.3.3-7	Section showing IC 74LS74 at E3 and part of Associated Loop.	30
3.3.4-1	Pin 15 of IC 74166 at C4	34
3.3.5-1	Sample	39
3.3.5-2	Section showing Sample.	38

Chapter 1

INTRODUCTION

The tremendous success of Midway's Gunfight and Sea Wolf games in the coin-operated amusement industry has created a new kind of need. This need has been felt because of the deviation from the usual TTL and the advancement into the Microprocessor (CPU) and the associated circuitry involving RAMS and PROMS. Much has been said and talked about regarding the CPU, RAMS, and PROMS both in the literature and outside, but little has been said or done about troubleshooting a board using these. Hence, this book has been specifically tailored to meet the requirements of troubleshooting Midway's Processor Boards*, (henceforth - referred to as Mother Boards). It does not in any way try to explain how the board works. Throughout the book the major emphasis has been on "How to Fix the Board" and no attempt has been made to describe "How it Works".

The Mother Boards used in both the games Gunfight and Sea Wolf are identical except for the Program part. However, to facilitate the writing of this book reference has been made to the Gunfight game. Substituting "Ship" for "Cowboy" in this book should enable fixing the Sea Wolf games as well.

* The turnout percentage of these boards at Midway Mfg. Co. is of the order of 99.7%. This relatively small fall-out is mainly attributed to the manufacturing defects of boards and not the troubleshooting procedures used!

Chapter 2

ASSUMPTIONS

1. It is assumed that the Mother Board was working once and has gone bad during use, that is, there are no shorts on the board. However, instances where shorts could exist and cause grave problems have been taken into consideration.

2. It is assumed that (a) the Power Supply, (b) the Game Board, and (c) the Tester are all in good working condition. Also the Monitor is synchronized.

3. It is assumed that the Operator has the following available:

- (a) A 50 MHz Oscilloscope
- (b) A Ram Test Board with a good Test PROM
(GUN FIGHT & SEA WOLF ONLY)
- (c) A set of good ROMS or PROMS

Chapter 3

TEST PROCEDURE

3.1 PRELIMINARY INSTRUCTIONS:

- (a) Make sure the Mother Board looks physically OK - no hanging jumper wires or burnt out chips.
- (b) Make sure that the jack from the Tester to the Mother Board is tight and properly connected.
- (c) Make sure the Game Board fits into the Mother Board jack tight. It is not necessary to hook up the Game Board jacks from the Tester at this time. Remember that without the Game Board or Ram Test Board in the Mother Board jack the CPU would not operate. The main criteria here is that "Hold" (pin 13 of CPU) should be low.
- (d) Turn on the Power Supply switch.
- (e) Check the following: +5V, -5V, +12V, VRA₊+5V, VRB₊+5V. (If VRA or VRB is low cut out the 0.1 MF Capacitor near A3 and A5. If it is still low refer to Case C, Step 3).

(f) Make sure that CPU socket is not broken and the PROMS are not loose in their sockets.

(g) What is seen on the screen would naturally vary from board to board. Each of these is discussed separately. Proceed to the relevant case.

NOTE: It has been observed that on boards where -5V was lost and the game was left ON for a long time all 16 of the RAMS were burnt out.

3.2 CASE A: GOOD PICTURE - BAD PROGRAM

By good picture is meant here a clear screen with the words "Game Over" and "0" on either side of it. In the case of a good Mother Board the words "Gun Fight" would be seen followed by the Cowboy coming in, shooting a bullet downwards, and walking back. During this process the words "Insert Coin" would appear on the lower right hand side temporarily (Figure 3.2-1). If all or part of this is bad it could most likely be a program problem.



(a) Gunfight

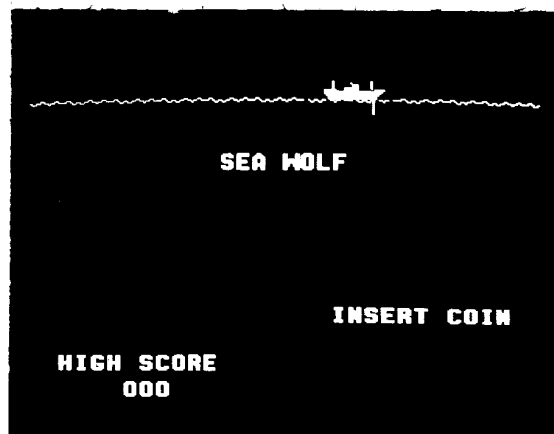

(b) Sea Wolf

Figure 3.2-1 Good Picture with Good Program

Try changing the PROMS one at a time till it is rectified. If the program seems alright and the Cowboy shape or movement is bad go to Case D.

If the above checks OK hook up the Game Board jacks and play the game. If the game cannot be played correctly (e.g. picture breaks down when one Cowboy shoots another, other characters instead of numericals appear at time count, etc.,) then the problem could most probably be in the PROMS. Try changing them one at a time.

In some instances it is a good idea to check the Ram Test out all the way. Though the Ram Test should be expected to work this is a good procedure and is recommended here.

3.3 CASE B: BAD PICTURE

When the words "Game Over" are not seen on the screen and the screen is filled with a lot of irrelevant, unintended material (Garbage) it is referred to here as bad picture. When the Mother Board gives a bad picture the first step would be to remove the PROM H from its socket. When PROM H is removed the screen should normally display good vertical lines (Figure 3.3.1-1). In some instances, however, the vertical lines may be present but bad, or there may not be any vertical lines at all. It is suggested that all the PROMS be removed at this time. Depending on the pattern displayed on the screen go to the relevant section

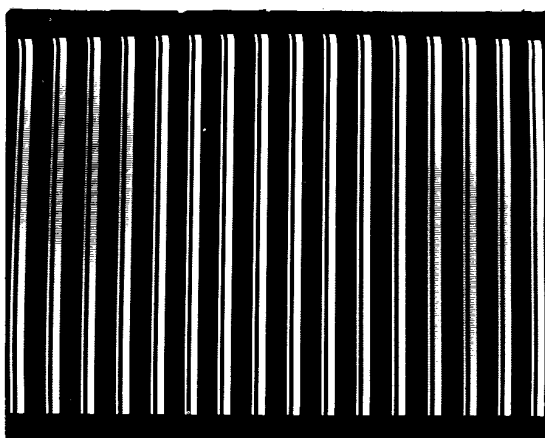
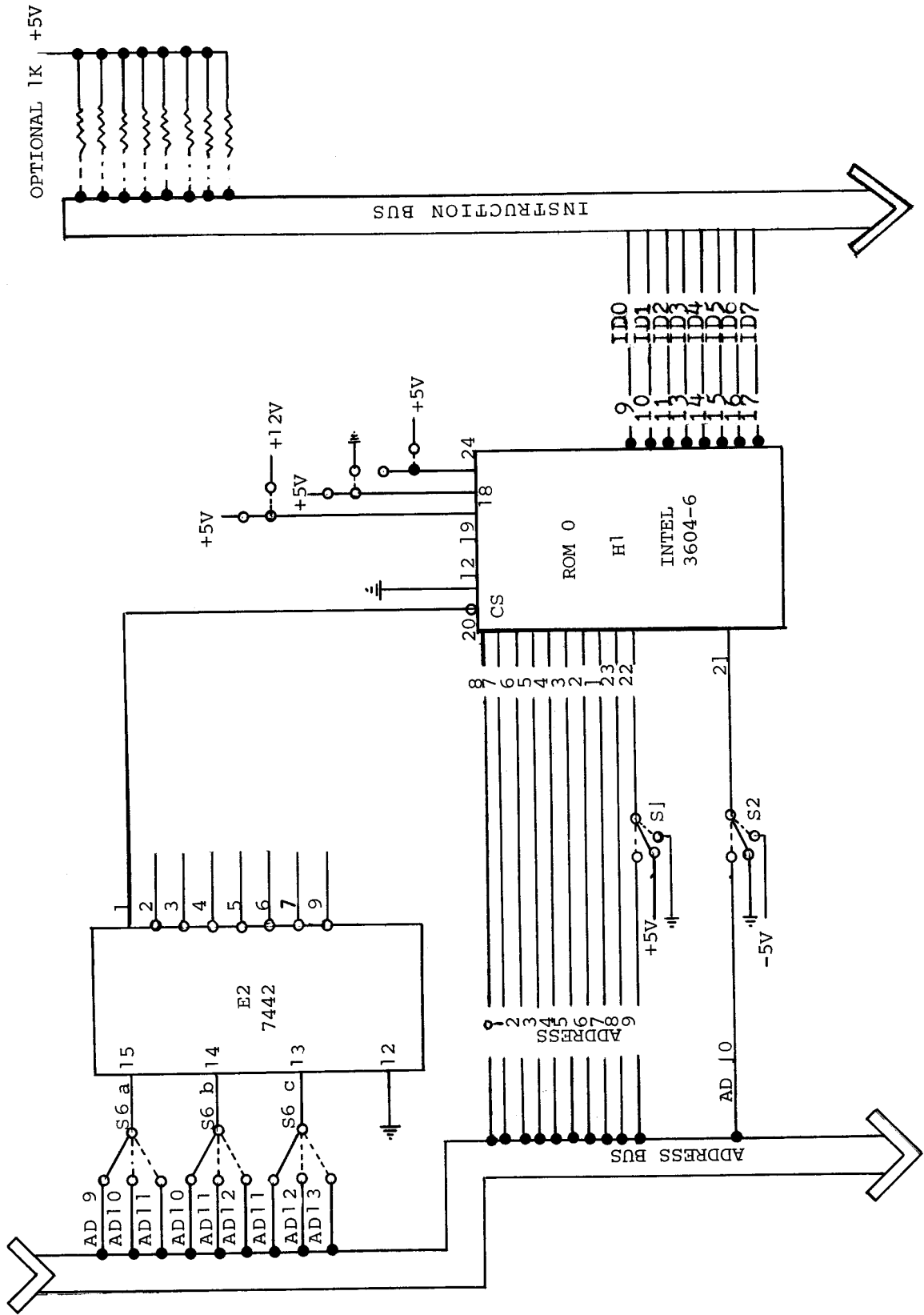

Figure 3.3.1-1 Good Vertical Lines

3.3.1 CASE B1 - GOOD VERTICAL LINES: The vertical lines are said to be good when there are sixteen clean vertical columns on the screen. Each column consists of 16 lines. Only 4 of these are ON at a time and these are arranged in the following order: 1 line on, 2 lines off, 3 lines on, and 10 lines off. If the vertical lines are good hit the tilt (Reset) switch till the pattern shifts on the screen. If the second pattern is also good it means that the CPU and RAMS are most probably working well. If one or more of these lines are bad or displaying dots on screen possibly the problem rests in the RAMS, then to to Case B2.

FIGURE # 3.3.1]-2: SECTION SHOWING PROMS AND IC 7442



If the vertical lines check good perform the Ram Test. (If the Mother Board uses 8K ROMS all of them should be removed to perform the Ram Test). If the Ram Test stops after a few scans the board would read out the bad RAM which should be changed. If the Ram Test runs all the way the problem rests with the program. The PROMS should be changed one at a time to get a good picture. Of course, PROM H should also be inserted at this time. Even after changing all the PROMS if the picture is still bad then it means that there is a break on the lines leading to the sockets. The best thing to do at a time like this is to remove all the PROMS and check all the pins for continuity (Figure 3.3.1-2). Generally the problem should be isolated by this time. If not, specifically check all the pins on IC 7442 at E2. There should be high frequency pulses on all pins 1 through 9 except 8 which is ground. (In the case of boards using IC 3205 in place of IC 7442 the corresponding pins are 7 and 9 thru 15).

NO RAM TEST

A number of causes could result in a No Ram Test situation. The following hints should however be helpful:

1. Make sure that the ID lines reach the PROM H socket (pins 9, 10, 11, and 13 thru 17) and are not short to one another. This could be done by grounding one at a time and checking the others with a scope. On Mother Boards using 8K ROMS the lines should be floating and on those using 4K PROMS the lines should be high.

FIGURE # 3:3.1-3: SECTION SHOWING IC 74]74s

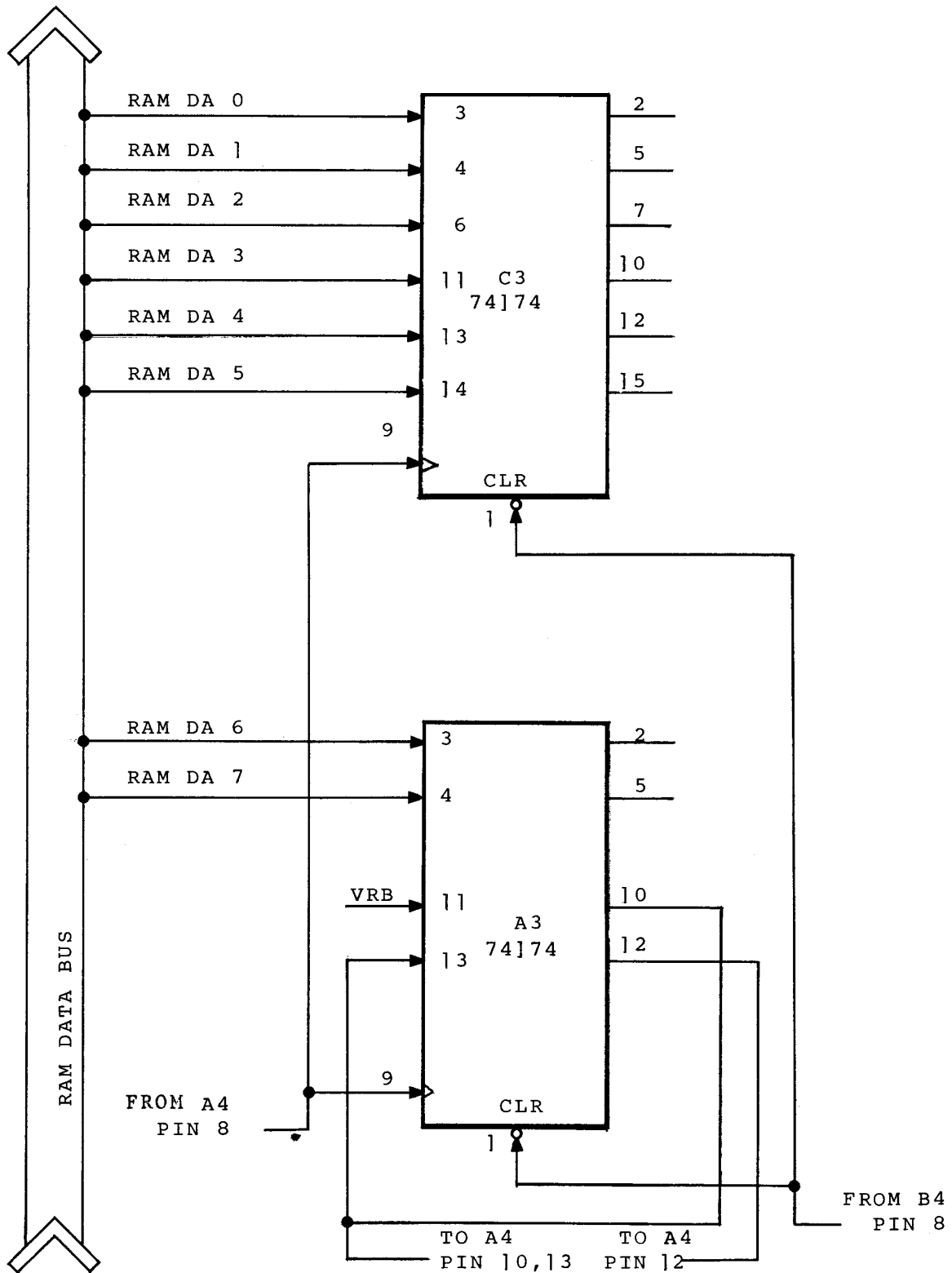

2. If the ID lines check OK, and they should on most boards that were working before, with the TEST PROM Cable removed check the outputs (Figure 3.3.1-3) of the IC 74174's at A3 (pins 2 and 5) and C3 (pins 2, 5, 7, 10, 12, and 15). Pins 2 and 5 on A3 and pins 5 and 7 on C3 should be low and there should be pulses on all the rest (Figure 3.3.1-4). If this condition is not met follow the line backwards to isolate the problem. A good trick at this point would be to ground these pins one at a time and hit the tilt (Reset) switch to see if it starts the Ram Test. IF it does it would stop after 1 scan. This would indicate that the problem is on that line. Follow it backwards and check all pins on the corresponding pair of RAMS. Change the corresponding IC 74174 if necessary.

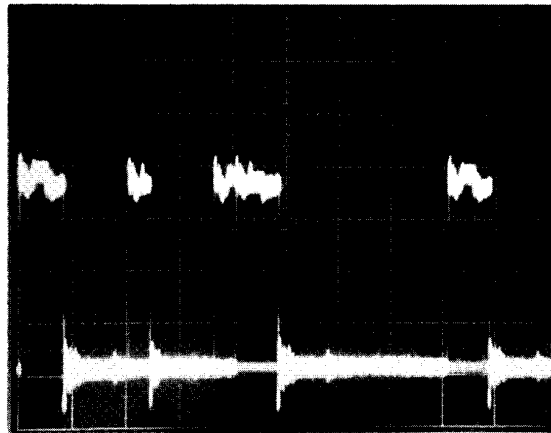
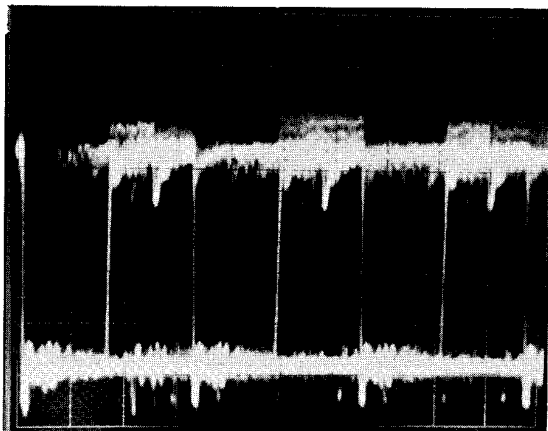

Figure 3.3.1-4 Waveform at C3 Pin 2
Vert: 1V/div, Horz: 2 μ Sec/div

3. IF 1 and 2 do not locate the problem check the RAM Addresses (Ram Ads) going to the RAMS for shorts and/or breaks. It is generally sufficient to check all pins on H8, G8, H15, G15. If any of the Ram Ads look fishy check the inputs to the corresponding IC 9322 or IC 74157 at F4, F5, F6, or F7. (Figure 3.3.1-5). If necessary change the chip.

4. If the Ram Test board reads out a RAM as bad check all pins on that RAM before changing it. The Ram Test board generally helps to narrow down the problem area.



(a) With Information

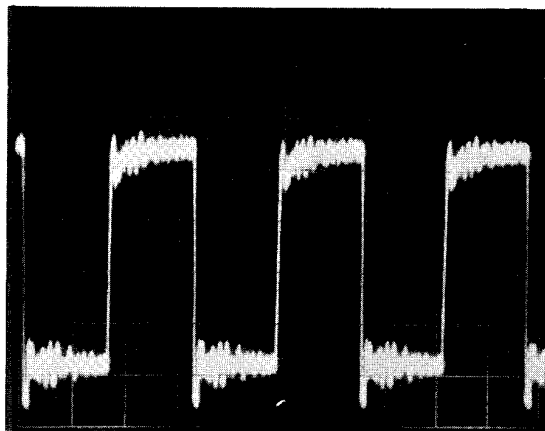

(b) Without Information

Figure 3.3.1-5 Ram Address
Vert: 1V/div, Horz: 0.5 μ Sec/div

5. In some instances the Multiplexers (IC 74153's) could go bad and cause the No Ram Test situation. This could be verified as follows: Check the output pins 7 and 9 on A2, B2, C2, and D2. There should be pulses on all of them (Figure 3.3.2-6). Now ground the corresponding ID inputs (pins 4 and 12) of each of these outputs and observe them. All the outputs except pins 7 and 9 of D2 and 7 of C2 should go low when the corresponding ID lines are low. On these three, however, there would be some obvious change in pulse duration and frequency. If any of the IC 74153's does not behave as described above it should be changed.

FIGURE # 3.3.2-1: SECTION SHOWING RAM INPUTS

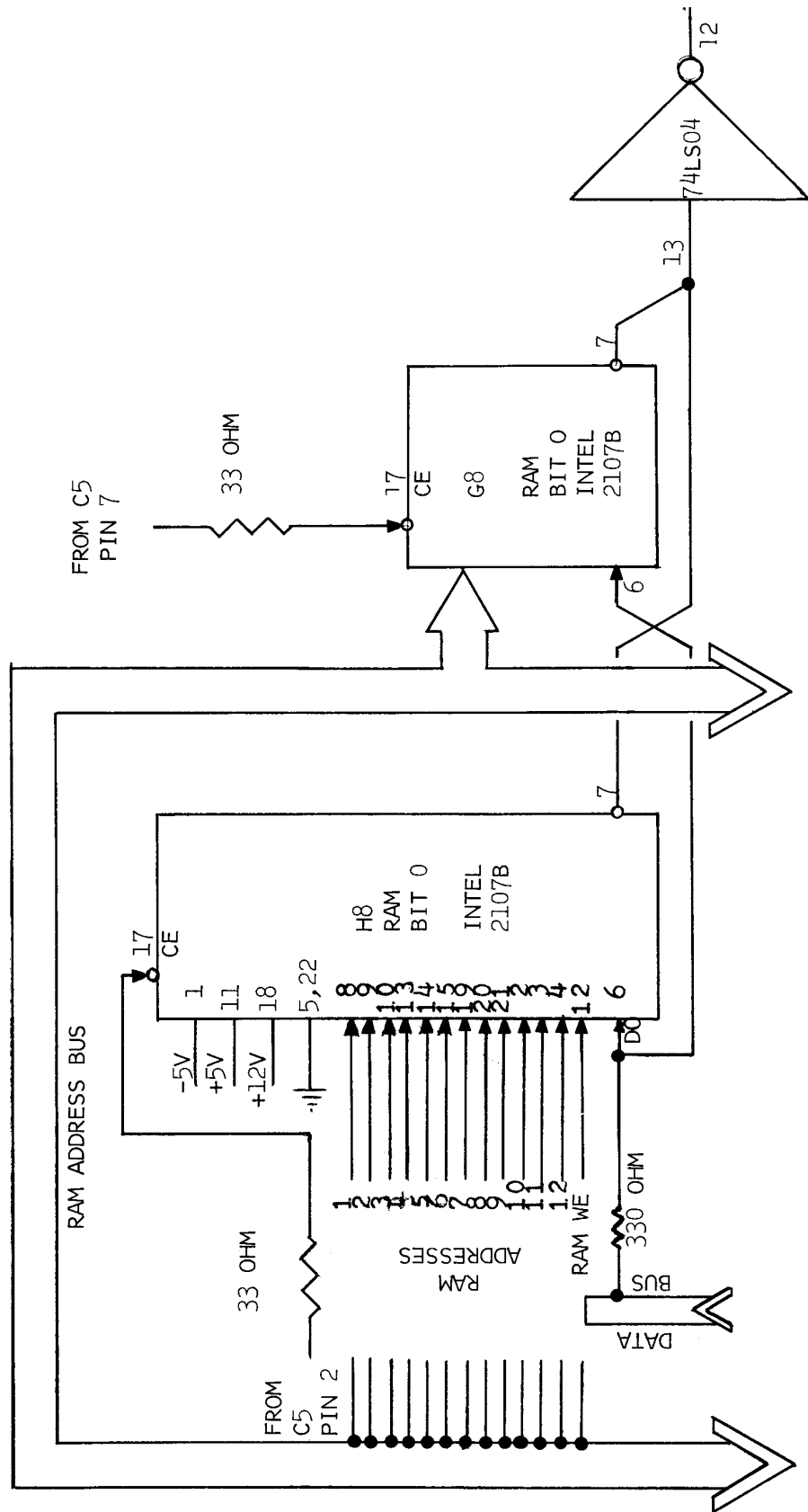

3.3.2 CASE B2 - BAD VERTICAL LINES: By bad vertical lines what is meant here is that the vertical lines are present but there is "garbage" associated with it. The "garbage" basically is of three types. Type 1: In the form of dots scattered and/or uniformly distributed across the screen. Type 2: In the form of rectangular blocks running horizontally across the screen. Type 3: In the form of rectangular blocks running vertically on the screen. Type 1 is attributed to bad RAMS or missing Ram Address to the RAMS, Type 2 to a bad address line/s, and Type 3 to bad data line/s.

TYPE 1

When the problem is of this type the first thing to check would be the Ram Ads on all RAMS. As mentioned earlier it is generally sufficient to check all pins on H8, G8, H15, and G15 (Figure 3.3.2-1).

A typical Data Input to the RAMS and RAM outputs (both Bi-State and Tri-State) are provided in Figure 3.3.2-2, and Figure 3.3.2-3 respectively.

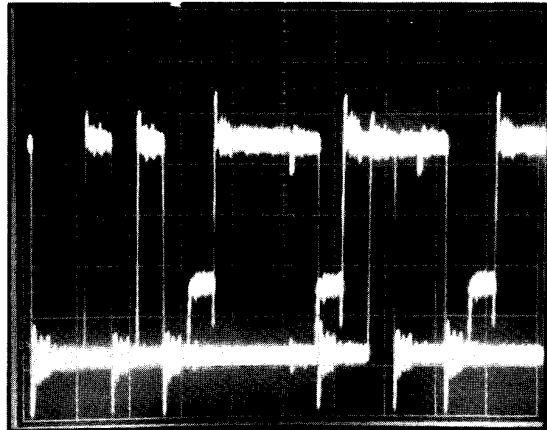
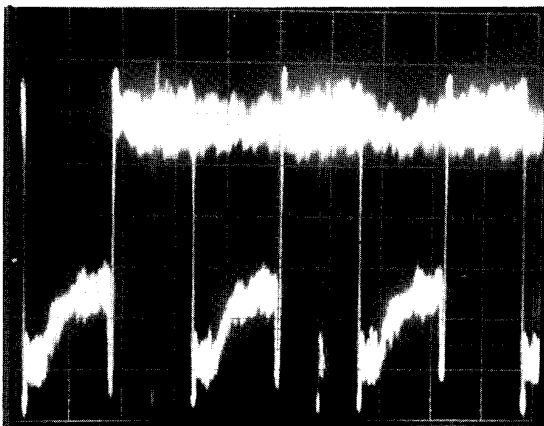

Figure 3.3.2-2 Good Data Input (Tri-State)
Vert: 1V/div, Horz: 1 μ Sec/div

To identify the RAMS causing the dots on the screen try the Ram Test first. If the test starts it

would stop at the dot and the board would read out the bad RAM.



(a) Tri-State

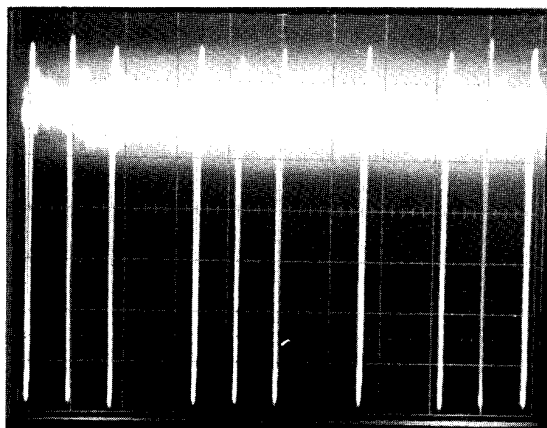

(b) Bi-State

Figure 3.3.2-3 Good RAM Data Output
Vert: 1V/div, Horz: 1 μ Sec/div

If the test does not start and still the board reads out a RAM as bad go to the output of that RAM (pin 7) and ground it. This

would verify the board by putting a white line through the dot. Change all RAMS necessary till the Ram Test runs all the way. Slightly adjusting the potentiometer (pot) of the +5V supply also helps in locating bad RAMS. If the board does not read out anything go to the inverters IC 74LS04 or IC 7404 at D4 and E4 and ground them out one at a time till it either takes the dots out or puts a line through them. This would naturally identify the pair of RAMS that could be bad. Check all pins on these RAMS for breaks, and the data input (pin 6) and output (pin 7) before changing them.

It has been observed that a bad Clock Driver (IC 3245) at C5 could cause dots on the screen. It is advisable to check this out by freezing or heating it as required and changing it if necessary.

In rare instances the IC 74LS08 at F3 could also cause dots. This could also be checked by freezing and heating as required.

- NOTE:
1. If there are full vertical lines in the wrong places it is advisable to check the input (pin 6) and output (pin 7) of the corresponding RAMS. If grounding the corresponding inverter pins does not take the line away then IC 74166 at C4 is bad and should be changed.
 2. It is very easy to make solder shorts or break lines when changing RAMS. So it is a good idea to exercise great care and check for shorts and/or breaks everytime a RAM is changed.

TYPE 2

When the address line/s are bad check all the inputs and outputs of the IC 74LS08's at G3, H3, F2, and F3. See Figure 3.3.2-4 for a sample of an address. It has been observed that this section has practically never caused any problems and hence is not emphasized here.

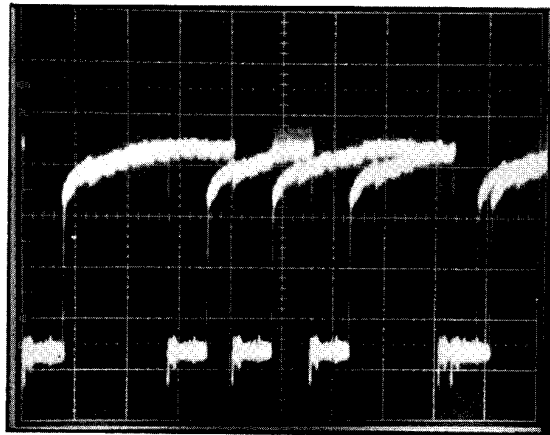

Figure 3.3.2-4 Good Address
Vert: 1V/div, Horz: 2 μ Sec/div

NOTES

This space is provided for personal notes

TYPE 3

When the data lines are bad check all the pins of the Bus Drivers IC 8216's at B3 and D3 (Figure 3.3.2-5). Figure 3.3.2-6 shows the input, Figure 3.3.2-7 shows the bidirectional line from the CPU and Figure 3.3.2-2 shows the output of the IC 8216.

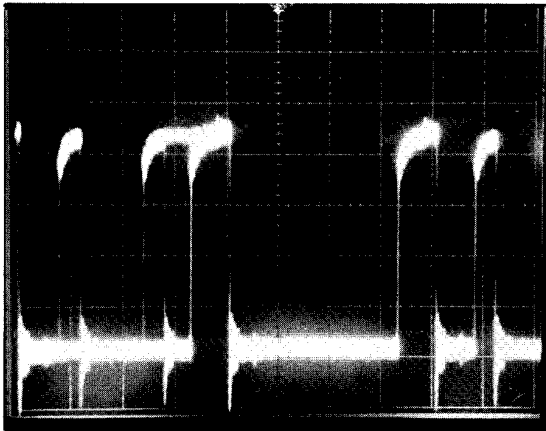

Figure 3.3.2-6 Input from
MUX to 8216
Vert: 1V/div,
Horz: 2 μ Sec/div

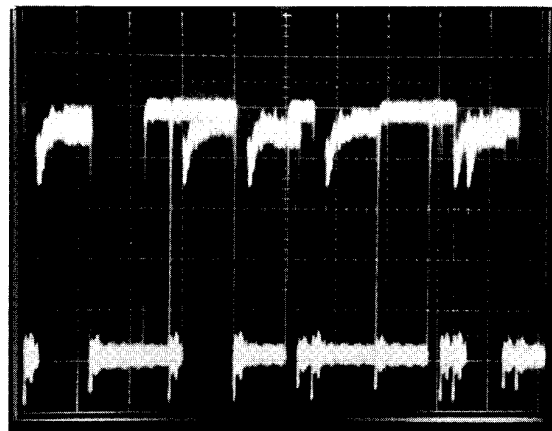
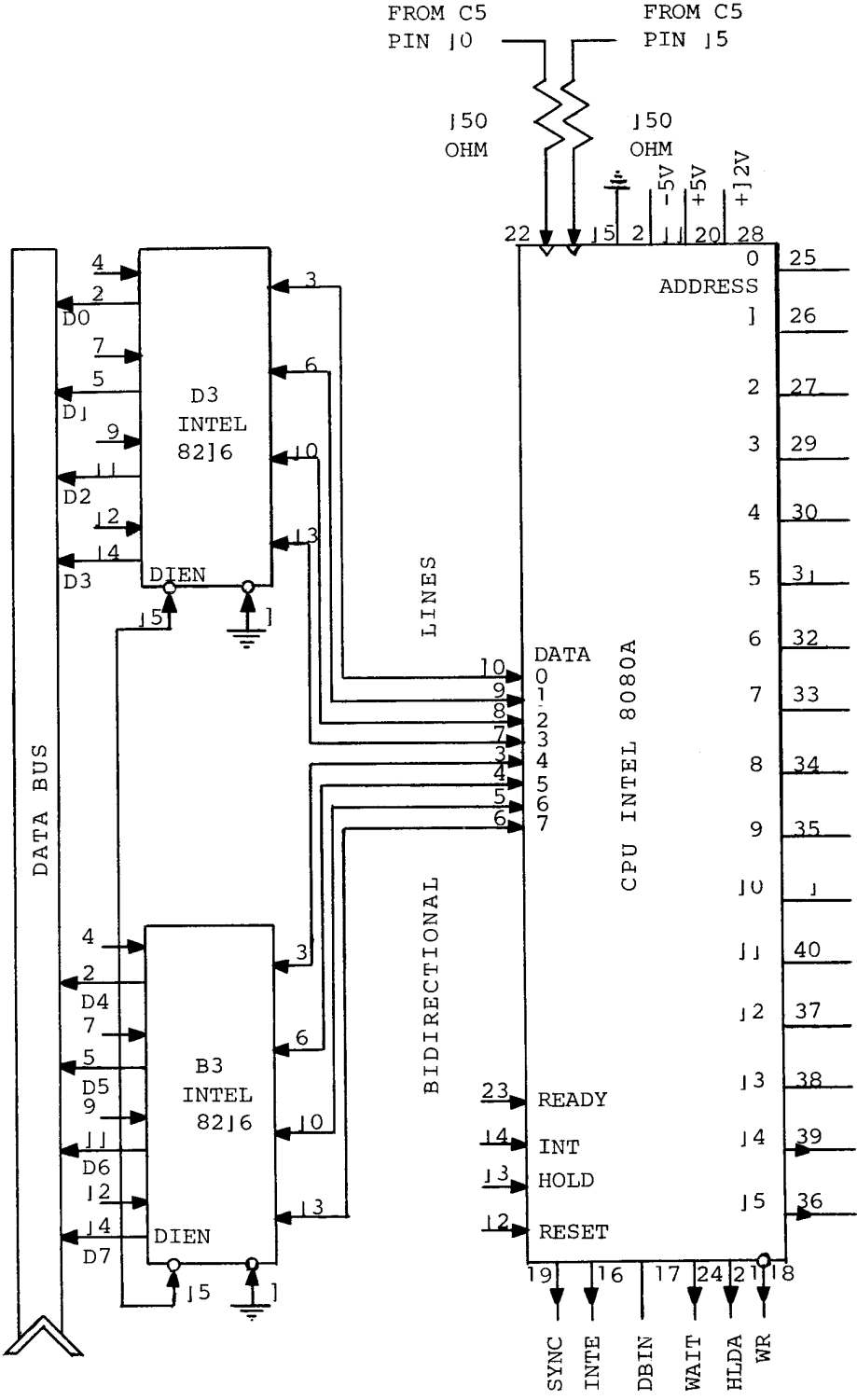

Figure 3.3.2-7 Bidirectional Line
Vert: 1V/div,
Horz: 2 μ Sec/div

FIGURE # 3.3.2-5: SECTION SHOWING BIDIRECTIONAL LINES



If the problem is found to be difficult to isolate it often helps to cut out the input pins 4, 7, 9, and 12 of the IC 8216's one at a time. Each time hit the Reset switch. If this helps follow that line backwards to the Multiplexer IC 74153 at A2, B2, C2, or D2 and check all the corresponding inputs and clocks (Figure 3.3.2-8 and 3.3.2-9) of the multiplexer.

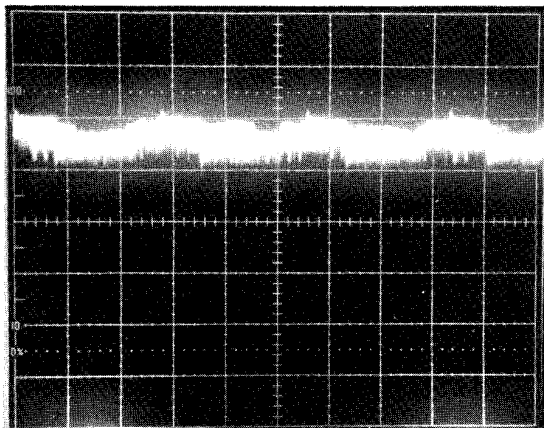

Figure 3.3.2-8
Clock at pin 2 of IC 74153
Vert: 1V/div,
Horz: 2 μ Sec/div

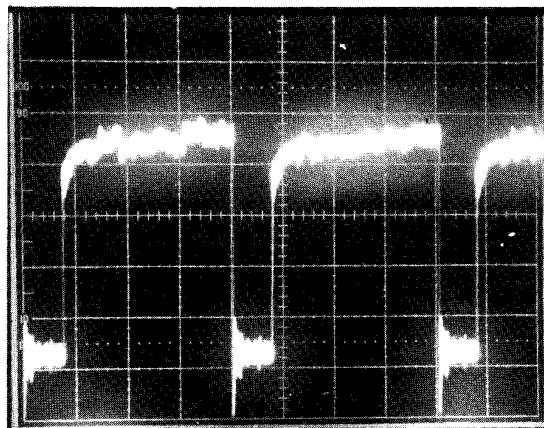

Figure 3.3.2-9
Clock at pin 14 of IC 74153
Vert: 1V/div,
Horz: 2 μ Sec/div

It has been observed that on repair boards this section is generally good. Changing the CPU and/or checking the bidirectional lines (from CPU to the 8216's) for continuity should help isolate the problem.

Once good vertical lines are obtained proceed as in Case B1.

NOTE: If the Mother Board uses a Sister Board (PC 80-902) in place of the IC 8216's it is often advisable to replace it with IC 8216's (This is only to facilitate troubleshooting). Make sure to connect the ground line back where it is cut (right below A2). If desired, after fixing the board the IC 8216's could be replaced by the Sister Board. It should also be noted that when a Sister Board is used IC 74253's are used as multiplexers in place of the IC 74153's. The IC 74253's require a block resistor going to the ID lines. When IC 8216's are used, however, all IC 74153's OR all IC 74253's could be used.

3.3.3 CASE B3: NO VERTICAL LINES: This means that the screen has no vertical lines present - just garbage on it. This could be caused for various reasons and the following procedure should be helpful in most cases.

1. Check the Clock Driver IC 3245 (4060 on some boards) output pins 2, 7, 10, and 15 (Figure 3.3.3-1).

2. If IC 3245 checks out good make sure the outputs reach their destinations - pin 17 on all the RAMS and pins 15, and 22 at CPU. Also doublecheck for +5V, -5V, and +12V at CPU.

3. Check pins 12 and 13 at CPU for low. Make sure the reset at pin 12 goes high when the tilt (Reset) switch is hit. If everything checks so far change the CPU.

4. If changing CPU does not help cut out pins 4, 7, 9, and 12 of the Bus Driver (IC 8216's) one at a time and proceed as in Case B2, Type 3. The cause could be a bad clock pulse on pin 2 and/or

FIGURE # 3.3.3-1: SECTION SHOWING CLOCK DRIVER INPUTS AND OUTPUTS

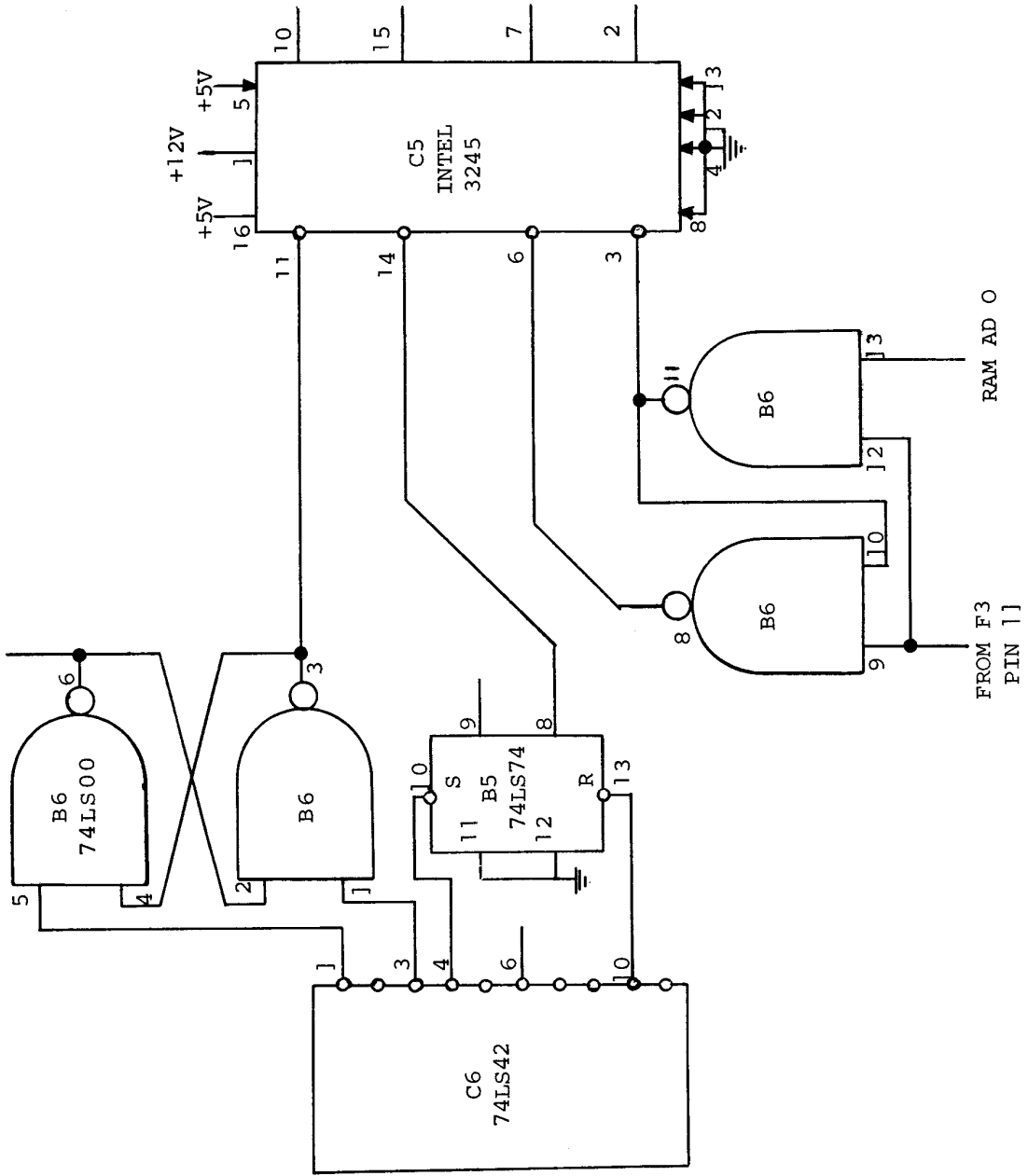

14 of the IC 74153's or pin 4 or 12 could be loaded down or it could be a bad chip. Change the IC 74153 if necessary.

5. If steps 1 through 4 do not bring the vertical lines back change the IC 74LS74 at E3.

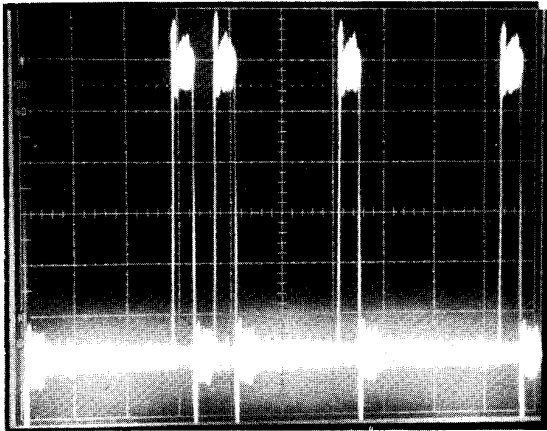

(a) At Pin 2
Vert: 2V/div,
Horz: 1 μ Sec/div

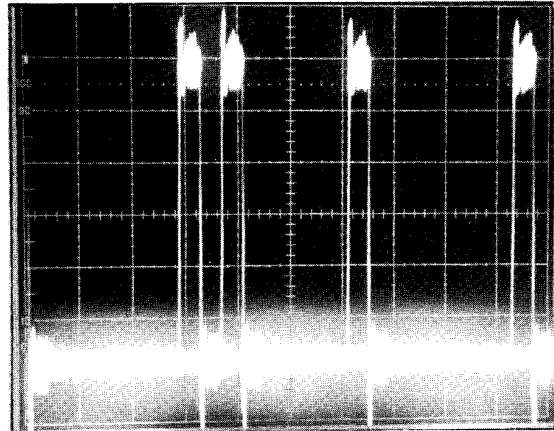

(b) At Pin 7
Vert: 2V/div,
Horz: 1 μ Sec/div

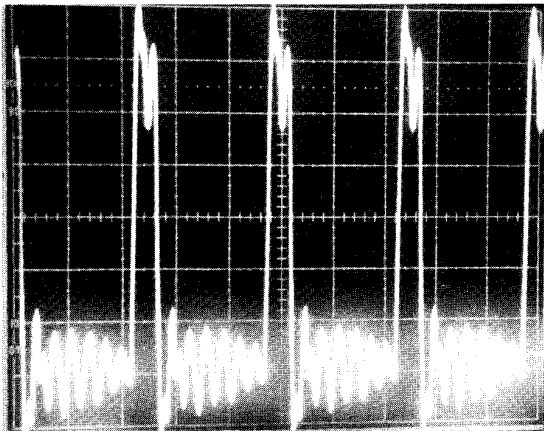

(c) At Pin 10
Vert: 2V/div,
Horz: 0.2 μ Sec/div

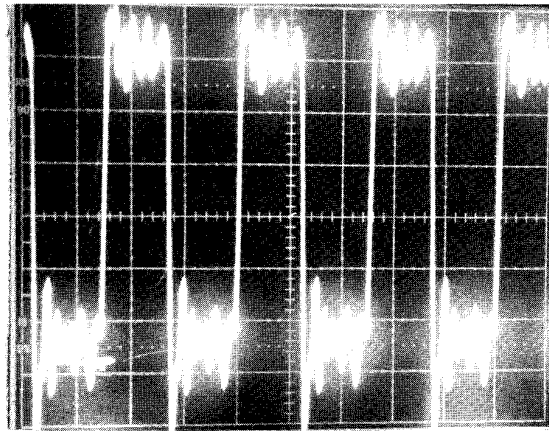

(d) At Pin 15
Vert: 2V/div,
Horz: 0.2 μ Sec/div

Figure 3.3.3-2 Clock Driver IC 3245 Outputs

6. If all pulses on E3 pins 9, 11, 12, 13 (Figure 3.3.3-3)

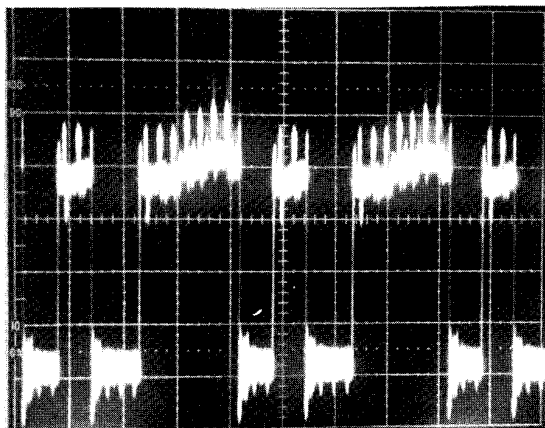

(a) At Pin 9
Vert: 1V/div,
Horz: 2 μ Sec/div

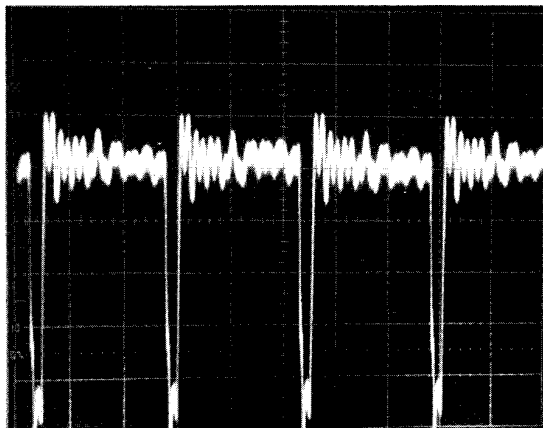

(b) At Pin 11
Vert: 1V/div,
Horz: 0.2 μ Sec/div

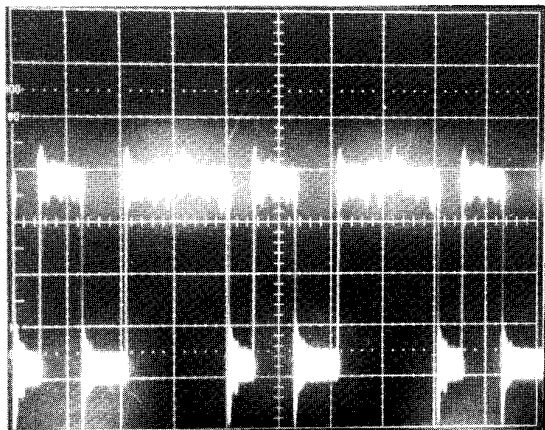

(c) At Pin 12
Vert: 1V/div,
Horz: 2 μ Sec/div

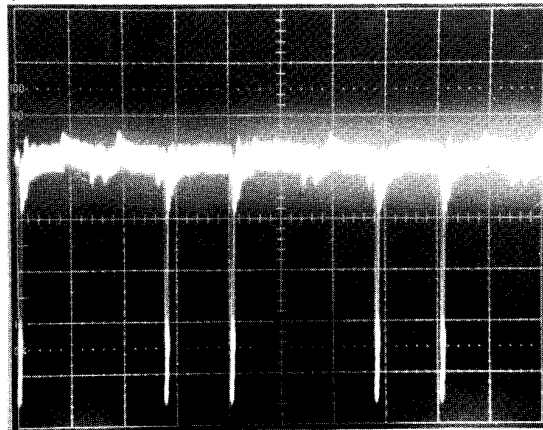

(d) At Pin 13
Vert: 1V/div,
Horz: 2 μ Sec/div

Figure 3.3.3-3 Flip Flop IC 74LS74 at E3

and . . .

pulses on pin 17, 18, 19 of CPU (Figure 3.3.3-5) look good and still the vertical lines are absent it is worth checking the write enable (Pin 12)

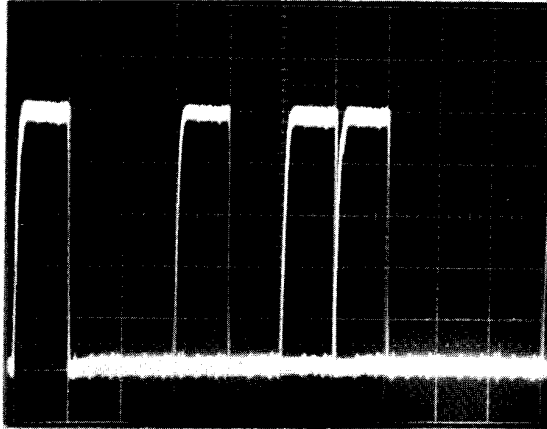

(a) SYNC - Pin 19
Vert: 1V/div,
Horz: 0.5 μ Sec/div

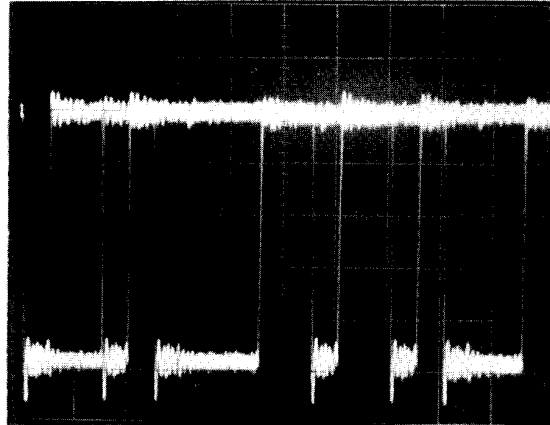

(b) WR - Pin 18
Vert: 1V/div,
Horz: 1 μ Sec/div

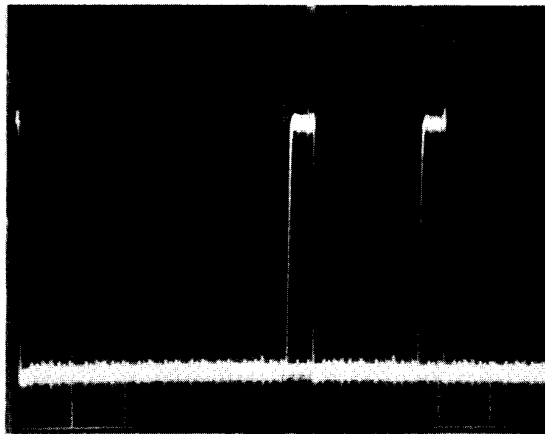

(c) DBIN - Pin 17
Vert: 1V/div,
Horz: 1 μ Sec/div

Figure 3.3.3-5 SYNC, WR, and DBIN at CPU

FIGURE # 3.3.3-4: SECTION SHOWING INPUTS AND OUTPUTS OF IC 9322 AT F4

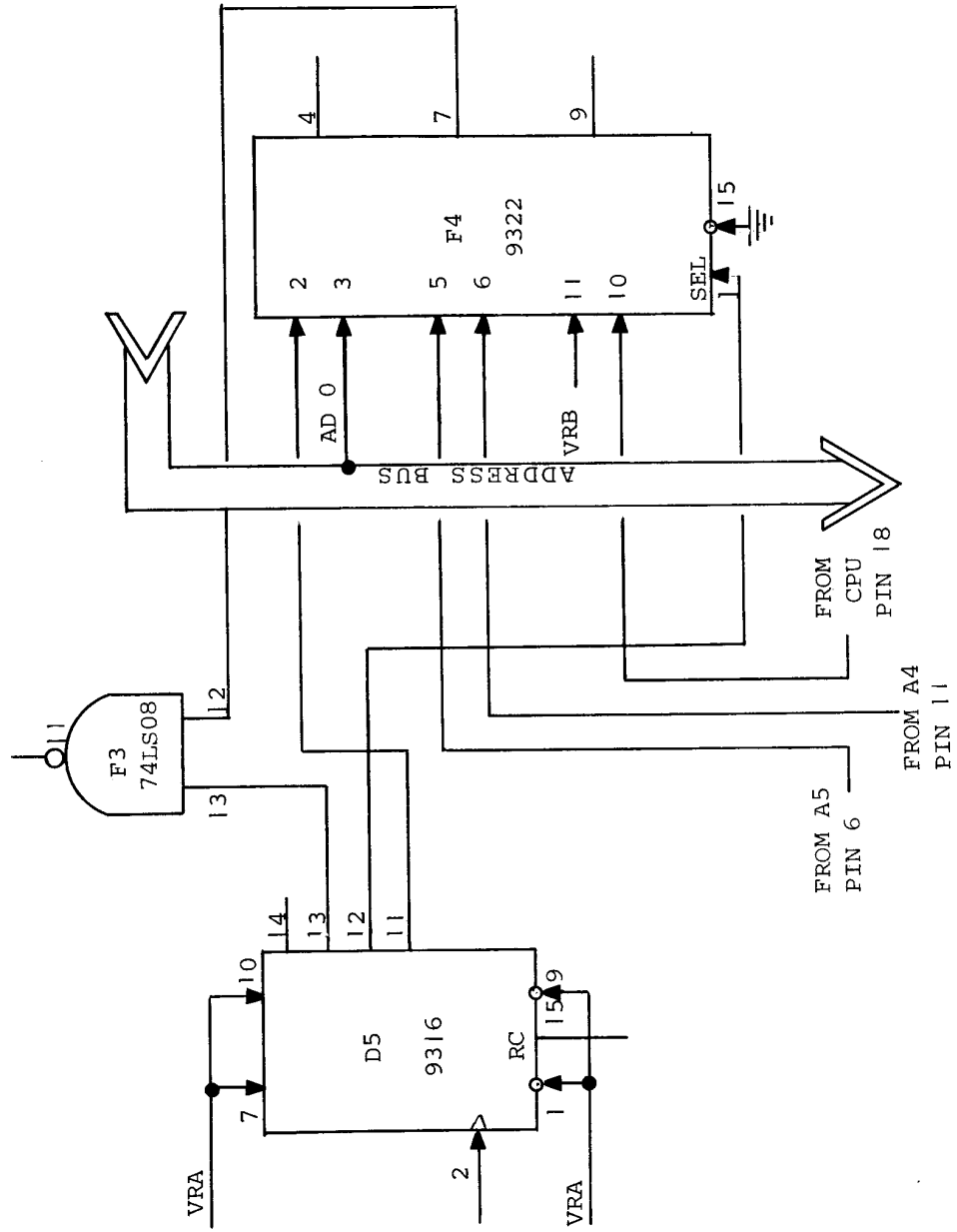

at the RAM (Figure 3.3.3-6). Also check the inputs and outputs of the IC 9322 at F4 (Figure 3.3.3-4).

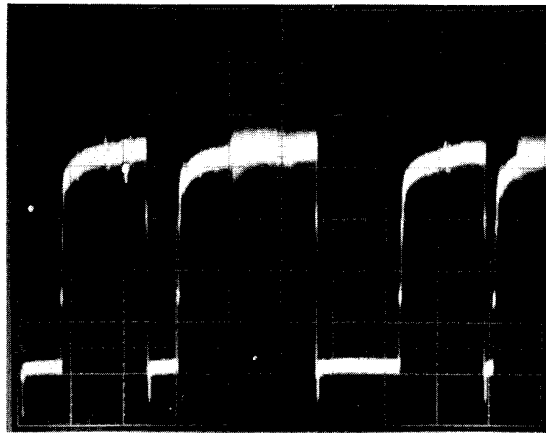
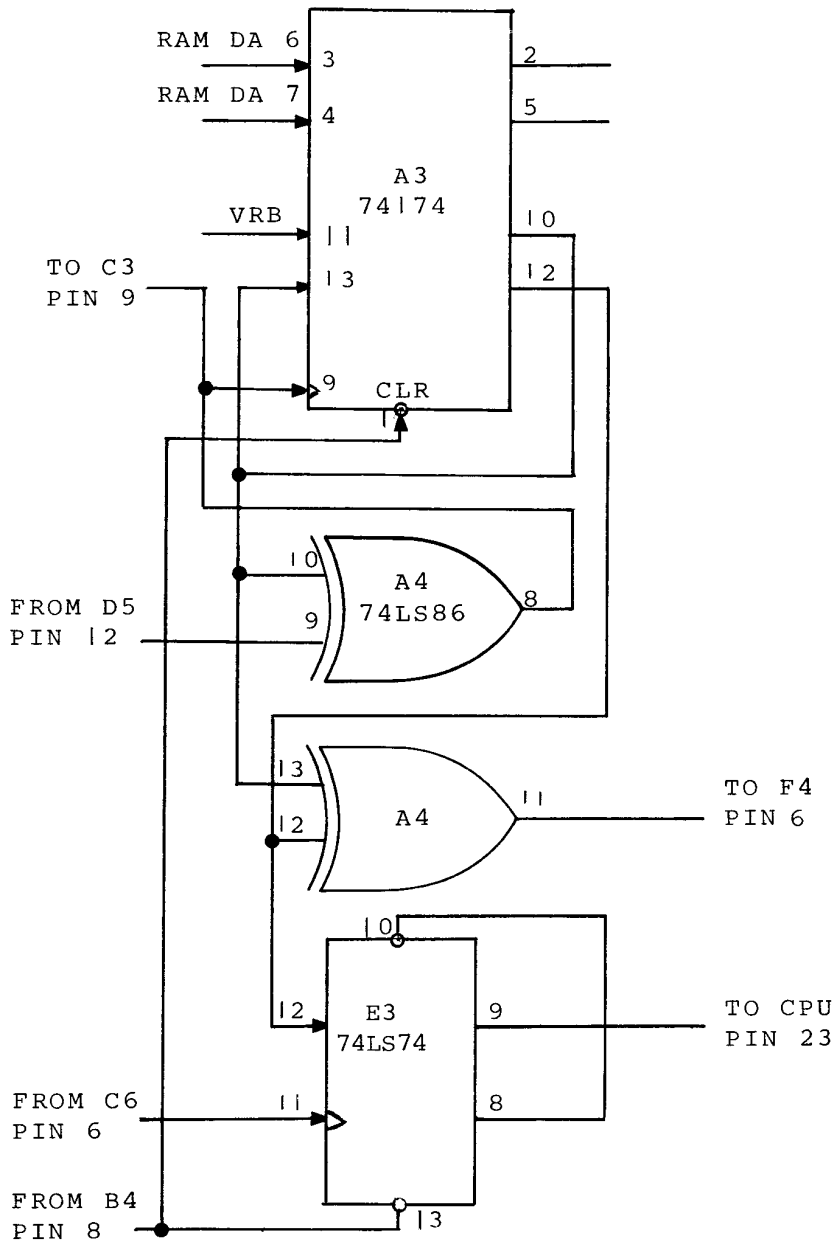

Figure 3.3.3-6 RAM WE - Pin 12 of RAMS
Vert: 1V/div, Horz: 0.5 u Sec/div

FIGURE # 3.3.3-7:
SECTION SHOWING IC 74LS74 AT E3
AND PART OF ASSOCIATED LOOP



7. If the vertical lines are not obtained by this time the problem could be a difficult and involved one. Check for the following conditions (Figure 3.3.3-7):

	<u>Pins High</u>	<u>Pins Low</u>
On CPU	18, 23	17, 19
On IC 74LS74 (E3)	9, 12, 13	8, 10

Pin 11 on IC 74LS74, should have a clock pulse (See Figure 3.3.3-3). As mentioned above pin 9 (READY) on IC 74LS74 (i.e. pin 23 of CPU) should be a high with some 0.5V noise on it.

If pins 12 or 13 of E3 are low this will cause pin 9 to go low. Follow the low one backwards and isolate the problem. This may require changing the IC 7420 at B4 or IC 7486 at A4. It should be emphasized here that a problem of this kind is hard to solve. The best that could be done under the circumstances is to make sure ALL the connections in the loop are correct and continuous. The other Flip Flop on E3 (i.e. pins 1 through 7) could be ignored at this time.

NOTE: Sometimes when pin 12 on E3 is low it helps to cut it to isolate the problem. When pin 12 is cut, and the CPU is Reset there should be pulses on all pins of E3 (8, 9, 10, 11, and 13). Though this is of the WRONG FREQUENCY it might help in some cases to pinpoint the problem.

8. Once vertical lines are obtained proceed as in Case B1.

3.4 CASE C: NO PICTURE

This means that there is nothing on the screen - in other words it could also be called "DEAD". This could happen for a number of reasons and could usually be rectified by following the instructions below:

1. Check for +5V. If this is missing and it is certainly not the Power Supply the short or chip that is loading it has to be located by cutting lines.

2. Check for +12V. In a number of cases the +12V gets loaded for some reason. Most commonly the 22 MF Capacitors near the RAMS H8 and H15 short out. So cut them out. Generally when a capacitor is the cause the line would be floating at about +1V. If cutting these caps out does not help then cut out pin 1 of the Clock Driver IC 3245 at C5. If +12V is recovered change C5. In the case of Gunfight using 8K ROMS the +12V line goes to pin 19 on the ROMS. Make sure that all ROMS are out and it is not here that it is loaded. If still the +12V is not recovered start cutting the lines near the RAMS and locate the bad RAM or short that is loading it down.

3. Check VRA and VRB at the resistors near A3 and A5. They should both be about +5V. If not, follow that line and find the short or chip loading it. The following table lists the pins to which VRA and VRB go.

VRA			VRB		
<u>Chip #</u>	<u>Location</u>	<u>Pin #</u>	<u>Chip #</u>	<u>Location</u>	<u>Pin #</u>
74LS74	A5	1, 4, 10, 13	74174	A3	11
7486	A4	5	74153	A2	6, 10
74LS74	B5	4, 1	74153	C2	6
9316	D5	1, 7, 9, 10	74153	D2	6, 10
74166	C4	9	74174	E3	4
9310	C7	1, 7, 19, 10	9322	F4	11
74174	D7	1			
9316	E5	1, 7			
9316	E6	1			
9316	E7	1			

Table: Pins to which VRA and VRB lead to

4. Check if the Crystal is tight in its' socket. Also check if it is working.

5. If +5V and +12V check good and still the board is dead check pin 15 of the IC 74166 at C4. The pulse should be as in Figure 3.3.4-1. If it is just a high check the clock section out. The clock section test is given in the Appendix.

6. If the clock checks good then check the Clock Driver IC 3245 at C5 outputs. As mentioned elsewhere there should be +12V pulses on pins 2, 7, 10, and 15. See Figure 3.3.3-2. A low on 2 or 7 could cause no picture condition. Check these out on the other side of the coupling resistors as well.

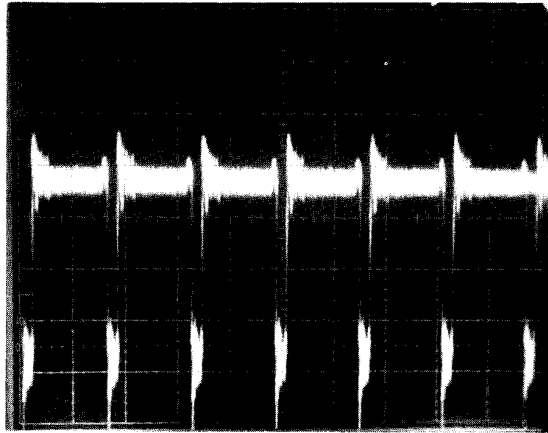

Figure 3.3.4-1 Pin 15
of IC 74166 at C4.
Vert: 1V/div, Horz: 1 μ Sec/div

7. The Write Enable on pin 12 of the RAMS should not be low. If this is so find the cause.

8. It has been observed that in some instances the IC 74166 at C4 was burnt out internally. If there are pulses on the inputs and clocks on pins 6, 7, and 15 of C4 and there is no pulse on pin 13 it is advisable to change IC 74166.

9. Sometimes the 10 MF video cap near the Mother Board jack could be bad and cause the no picture situation. This should be checked.

3.5 CASE D: BAD COWBOY

Most of the problems associated with the bad shape of the Cowboy or wrong (jumpy) movement are centered on the Game Board. However, in some instances the Mother Board could cause the Bad Cowboy problem. This is primarily because the Game Board requires certain information from the Mother Board and at the same time gives certain information to the Mother Board. Therefore, any problem related to the Cowboy has to be on these lines. The information coming into the Game Board is on the Data Bus (D0 thru D7) at pins 25, 26, 27, 28, and d, e, f, and h on the Mother Board jack. The Sample coming in at pin 31 plays an important role in the Cowboy movement. Also the three Addresses (AD 8, AD 9, and Ad 10) coming into the Game Board at Pins K, L, and M of the Mother Board jack play a dominant part in the shape and movement of the Cowboy. So the first place to check a bad Cowboy problem is at these pins ON the Game Board. A lot of times it is just missing information (e.g. a break or bent pin) from the Mother Board that causes these problems. In rare instances the block resistor going to the ID lines could cause a distorted Cowboy. In Mother Boards using IC 74153's as Multiplexers this block resistor could be safely removed.

LINES IN COWBOY

If the problem lies on the Mother Board it is most likely due to a break on the MX lines going from pins 33, 34, 35, 36, or n, p, q, and r at the Mother Board jack to the multiplexers at A2, B2, C2, and D2. A good and easy way to identify a bad MX line is to ground them one at a time and observe the Cowboy when he moves. Sometimes the corresponding multiplexer needs to be changed to correct the bad lines on the Cowboy.

FIGURE # 3.3.5-2: SECTION SHOWING SAMPLE

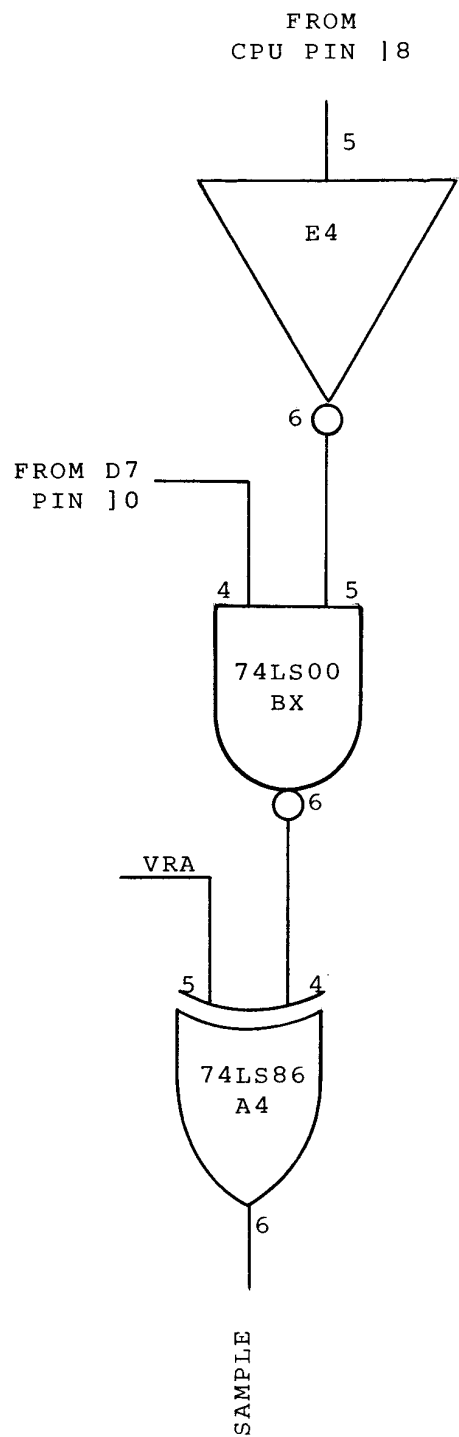

SAMPLE: The sample at pin 31 is a continuous low with a high going pulse (Figure 3.3.5-1) when the Cowboy walks in and out. If there is no pulse at pin 31 follow it backwards to A4 and BX (Figure 3.3.5-2). Check pins 4 and 5 of A4. Pin 4 should be a high with a low going pulse when the Cowboy walks in and out. Pin 5 should be a high. If pin 4 does not check correctly follow it further backwards to BX and check pins 4, 5, and 6 of BX. Pin 5 should have a continuous pulse as it comes from CPU pin 18 (Write Enable) through the inverter E4. If there is no pulse on BX pin 4 when the Cowboy moves in and out check the IC 74174 at D7 pins 10 and 11. If necessary change D7. Remember to keep the program running when checking the sample pulses.

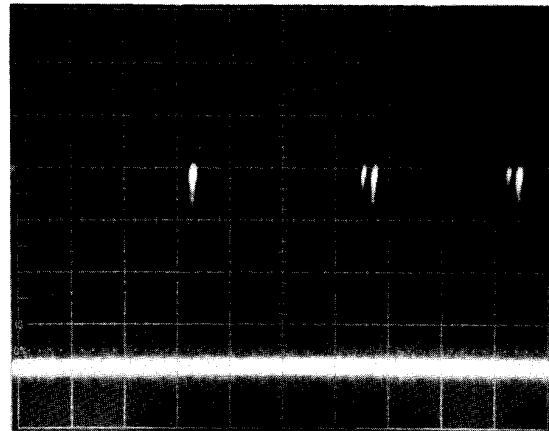

Figure 3.3.5-1 Sample
Vert: 1V/div, Horz: 10 μ Sec/div

A P P E N D I X

The Clock Section

Pin Configurations

Mother Board Schematic

APPENDIX 1

CLOCK SECTION CHECK

Remove all PROMS from their sockets. Check for +5V, +12V, -5V, VRA, and VRB.

At this time the screen should have vertical lines and/or garbage on it. If all or part of the screen is blanked out and it is not because of the NO PICTURE conditions listed in Case C, or if the picture keeps rolling, then it is referred to here as the Clock Problem. This could be rectified in most cases as follows:

- 1) Remove the Game Board.
- 2) Check the Write Enable pin 17 on the RAMS. They should be high and not loaded to another pulse or ground.
- 3) Check the Ram Enable pin 17 on the RAMS. They should be as in Figure 3.3.3-2 a, b. If they are at a different dc level or missing isolate the problem. The cause could be a bad IC 3245 or a bad RAM or a bad input to IC 3245.
- 4) Check the Shifter IC 74166 pin 15. The pulse should be as in Figure 3.3.4-1. If this checks good go to Step 7. If this is just a high check the entire clock section out for the conditions listed below.

(a) At C7 IC 9310: If pin 2 is bad then check the crystal and IC 74S04 (or IC 7404) at A7. If necessary change both.

If any of the outputs are bad cut the pins and check.

IC 9310	
PIN #	FREQ.
2	20MHz
11	2MHz
12	2MHz
13	2MHz
14	10MHz
15	2MHz

THE CLOCK SECTION

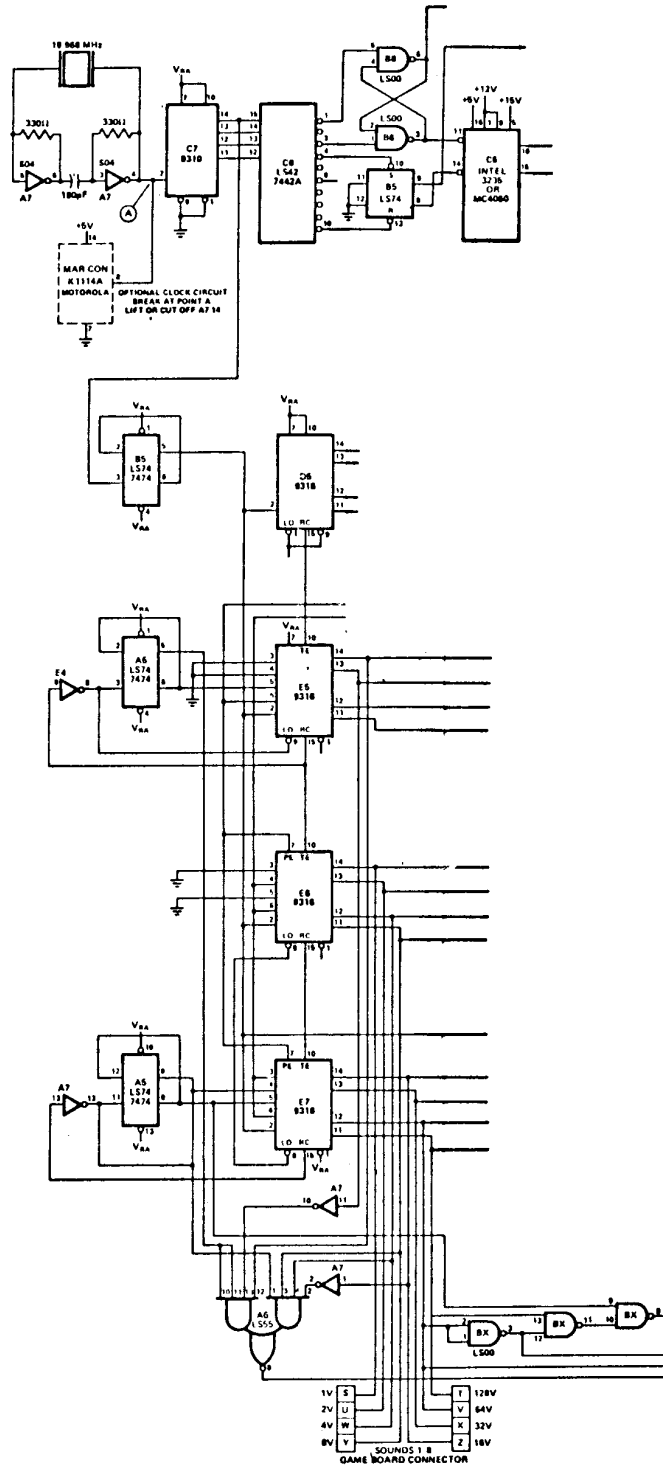

(b) At B5 IC 74LS74 (or IC 7474):
 Generally this should check out good. If not cut out pin 5 and check. If it is still bad change the chip.

IC 74LS74	
PIN #	FREQ.
5	5MHz
2,6	5MHz

(c) At A5 IC 74LS74 (or IC 7474):
 In some instances this section may not check. Rarely is it because of a bad chip. In most cases it is due to a discontinuity or short in the loop or it could be due to a bad IC 9316 (or IC 74161) at E5, E6, or E7. The following Table gives the outputs of these chips. It is advised that these be checked starting at D5 pin 14 and working downwards. Also check for the triggering pulses on pin 15 of these.

IC 74LS74	
PIN #	FREQ.
5	15.4KHz
2,6	15.4KHz
8,12	60Hz
9	60Hz

IC 9316's				
CHIP LOCATION	PIN # 11	PIN # 12	PIN # 13	PIN # 14
D5	245.76KHz	491.52KHz	0.98304MHz	1.96608MHz
E5	15.36KHz	30.72KHz	61.44KHz	122.88KHz
E6	960Hz	1920Hz	3840Hz	7680Hz
E7	60Hz	120Hz	240Hz	480Hz

If any of these happen to lie low or are bad (wrong frequency) it is advisable to cut the pin and check again. If it is still bad change the IC 9316. Generally this procedure should bring back the whole picture on the screen. If so the clock problem is solved. Proceed as in the main text.

5. If the clock problem still persists check IC 74LS20 at B4. Pin 6 should have a pulse of frequency 1.25MHz. If not check input pins 1, 2, 4, and 5. If inputs are good change B4.
6. If B4 pin 6 checks OK follow it through IC 74LS02 at D6 (pins 11, 12, and 13) and IC 74S04 at A7 (pins 9 and 8).
7. SYNC. PROBLEM: When the picture starts rolling it is generally a Sync. Problem. This is due to one of the inputs to the IC 74LS55 at A6 being of the wrong frequency. To facilitate the user a table of these inputs is given below. When any of these don't seem right a good trick would be to heat or freeze the corresponding IC 9316 and see if it stabilizes the picture. If so the problem could be solved by just changing the chip. Otherwise follow the suspected input backwards to the IC 9316 and isolate the problem.

IC 74LS55	
<u>PIN #</u>	<u>FREQ.</u>
8 (outputs)	15KHz
1	60Hz
2	480Hz
3	960Hz
4	1920Hz
10,11	15.4KHz
12	122.88KHz
13	61.44KHz

NOTE: In some instances the picture would be good, the Ram Test would be good but when the PROMS are inserted it gives multiple pictures. This is because of a missing pulse to the IC 9322's at F5, F6, and F7 from the corresponding IC 9316.

APPENDIX 2

PIN CONFIGURATIONS

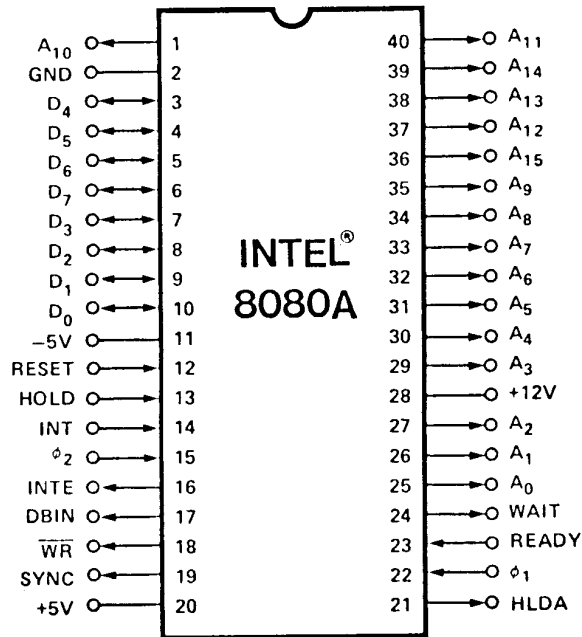

MICROPROCESSOR

PROM

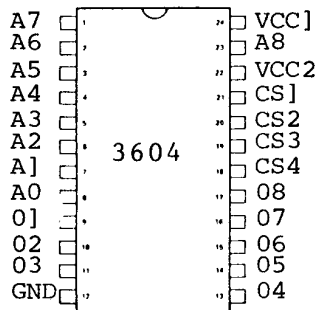

RAM

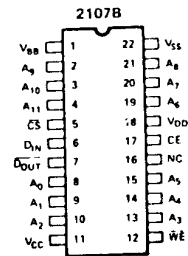

REQUIRED ON 3604-6 ONLY:

- A0-A8 ADDRESS INPUTS
- O7-O0 DATA OUTPUTS
- CS1-CS4 CHIP SELECT INPUTS

PIN CONFIGURATION

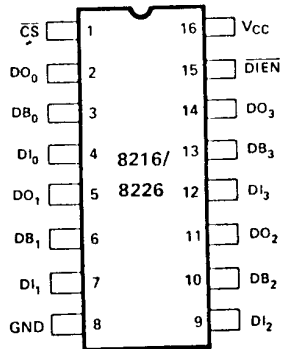

PIN NAMES

DB ₀ -DB ₃	DATA BUS BI DIRECTIONAL
DI ₀ -DI ₃	DATA INPUT
DO ₀ -DO ₃	DATA OUTPUT
DIEN	DATA IN ENABLE DIRECTION CONTROL
CS	CHIP SELECT

LOGIC DIAGRAM
8216

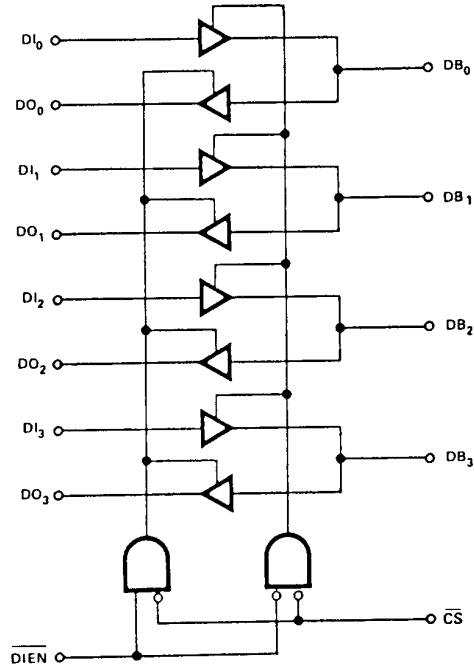

BUS DRIVER IC 8216

PIN CONFIGURATION

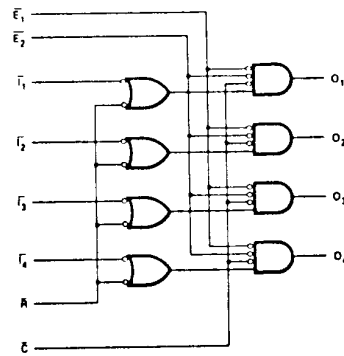
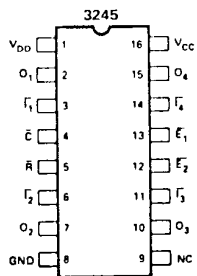

LOGIC DIAGRAM

CLOCK DRIVER IC 3245

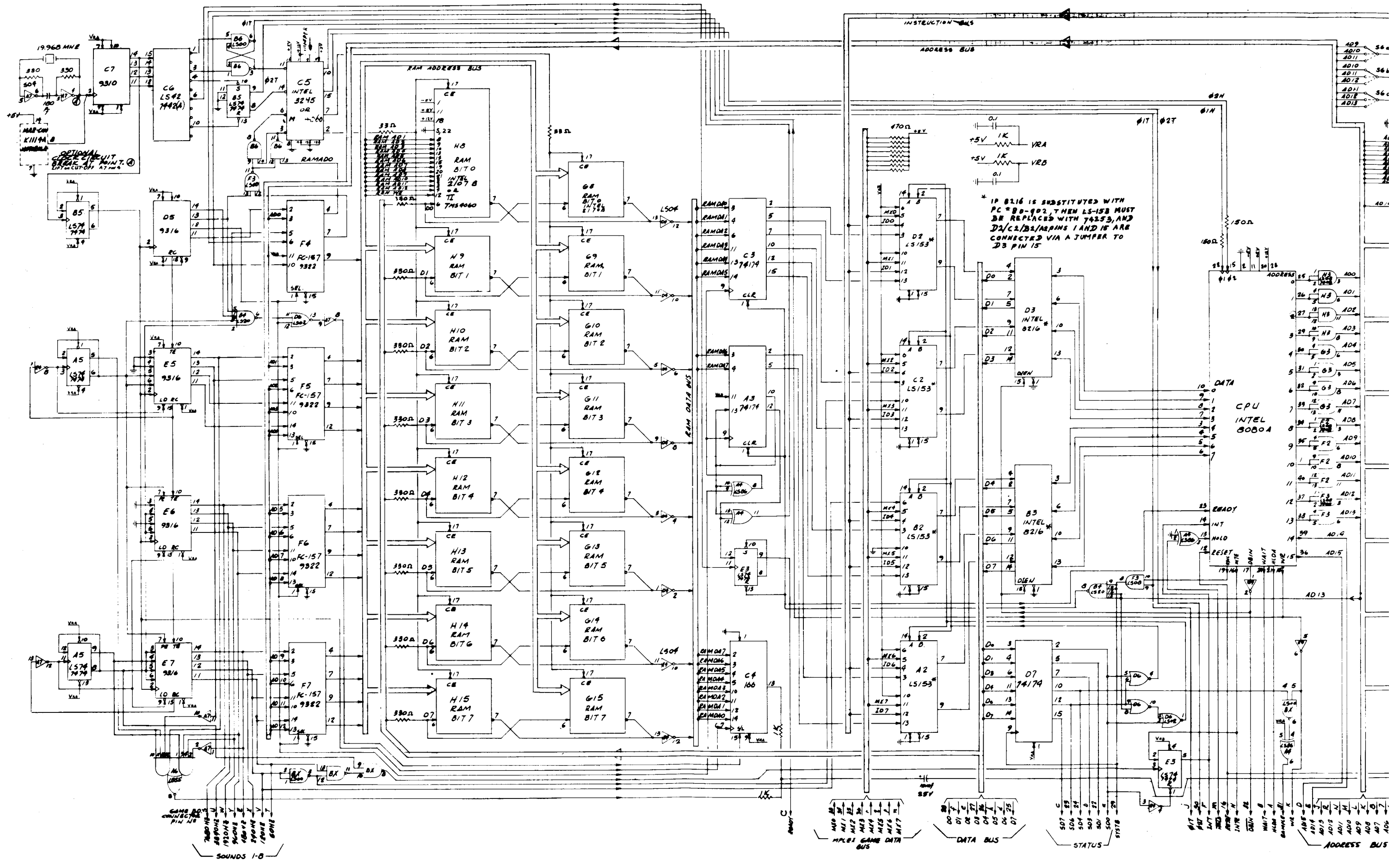

* IF 8216 IS SUBSTITUTED WITH PC-80-902, THEN LS-153 MUST BE REPLACED WITH 74253, AND D2/C2/D2/AS/PINS 1 AND 15 ARE CONNECTED VIA A JUMPER TO D3 PIN 15

CPU
INTEL
8080A

SOUNDS I-O

MPCE1 GAME DATA BUS

DATA BUS

STATUS

ADDRESS BUS

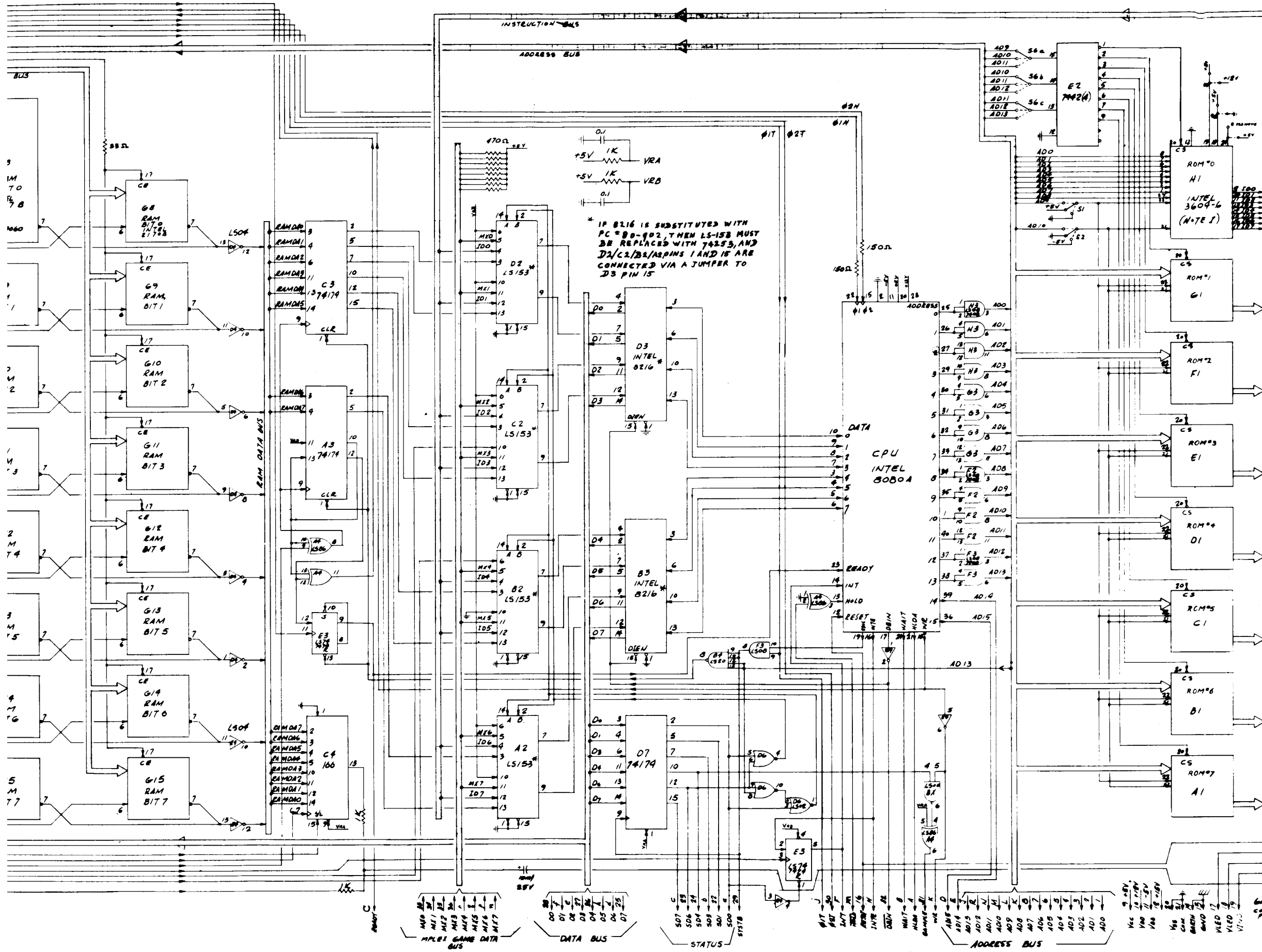

TTL = 7400 SERIES

Schematic

NOTE 1 OTHER AVAILABLE CHIPS AND STRAP ARRANGEMENT IF USED

MFG	NR	S1	S2	S3	S5	S6a	S6b	S6c	PNR
		PIN 22	PIN 31	PIN 19	PIN 18	PIN 15	PIN 14	PIN 13	PIN 12
INTEL	2308	AD9	-5V	+12V	COM	AD10	AD11	AD12	+5V NO
INTEL	2704	COM	-5V	+12V	COM	AD9	AD10	AD11	+5V NO
INTEL	2708	AD9	-5V	+12V	COM	AD10	AD11	AD12	+5V NO
INTEL	3308A	+5V	COM	+5V	+5V	AD9	AD10	AD11	+5V YES
INTEL	3308A-6	+5V	COM	+5V	+5V	AD9	AD10	AD11	PNW CUT-OUT YES
INTEL	3329A	+5V	COM	+5V	+5V	AD9	AD10	AD11	+5V NO
INTEL	3608	+5V	COM	+5V	+5V	AD9	AD10	AD11	+5V YES
INTEL	3608-6	+5V	COM	+5V	+5V	AD9	AD10	AD11	PNW CUT-OUT YES
INTEL	3628	+5V	COM	+5V	+5V	AD9	AD10	AD11	+5V NO
INTEL	3628-4	+5V	COM	+5V	+5V	AD9	AD10	AD11	PNW CUT-OUT YES
INTEL	8308	AD9	-5V	+12V	+5V	AD10	AD11	AD12	+5V NO
AMD	9208	AD9	X	+12V	COM	AD10	AD11	AD12	+5V NO
AMD	9216	AD9	AD10	+12V	+5V	AD11	AD12	AD13	+5V NO
AMD	27580	AD9	COM	+5V	+5V	AD10	AD11	AD12	+5V YES
AMD	27581	AD9	COM	+5V	+5V	AD10	AD11	AD12	+5V NO
HARRIS	7640-5	X	COM	+5V	+5V	AD9	AD10	AD11	+5V YES
HARRIS	7641-5	X	COM	+5V	+5V	AD9	AD10	AD11	+5V NO
FSC	93438	X	COM	+5V	+5V	AD9	AD10	AD11	+5V YES
FSC	93448	X	COM	+5V	+5V	AD9	AD10	AD11	+5V NO

