

# NX-15

## USERS MANUAL



### Federal Communications Commission Radio Frequency Interference Statement

This equipment generates and uses radio frequency energy and if not installed and used properly, that is, in strict accordance with the manufacturer's instructions, may cause interference to radio and television reception. It has been type tested and found to comply with the limits for a Class B computing device in accordance with the specifications in Subpart J of Part 15 of FCC Rules, which are designed to provide reasonable protection against such interference in a residential installation. However, there is no guarantee that interference will not occur in a particular installation. If this equipment does cause interference to radio or television reception, which can be determined by turning the equipment off and on, the user is encouraged to try to correct the interference by one or more of the following measures:

- Reorient the receiving antenna
- Relocate the computer with respect to the receiver
- Move the computer away from the receiver
- Plug the computer into a different outlet so that computer and receiver are on different branch circuits.

If necessary, the user should consult the dealer or an experienced radio/television technician for additional suggestions. The user may find the following booklet, prepared by the Federal Communications Commission helpful: "How to Identify and Resolve Radio-TV Interference Problems." This booklet is available from the U.S. Government Printing Office, Washington, D.C., 20402, Stock No. 004-000-00345-4.

For compliance with Federal Noise Interference Standard, this equipment requires a shielded cable.

*This statement will be applied only for the printers marketed in U.S.A.*

#### Self Declaration

Radio interferences regarding this equipment has been eliminated according to Vfg 1046/1984 announced by the DBP.

DBP has been informed about the introduction of this special equipment and has been conceded the right to examine the whole series.

It is upon the responsibility of the user to assume that his own assembled system is in accordance with the technical regulations under Vfg 1046/1984.

To observe FTZ-regulations it is necessary, to establish all connections to the printer with shielded cable.

The equipment may only be opened by qualified service representatives.

*This statement will be applied only for the printers marketed in West Germany.*

#### Trademark Acknowledgement

**NX-15:** Star Micronics Co., Ltd.

**Apple II:** Apple Computer Inc.

**EasyWriter II:** Information Unlimited Software, Inc.

**FX-85:** Seiko Epson Corp.

**IBM PC, IBM Graphics Printer:** International Business Machines Corp.

**Lotus 1-2-3:** Lotus Development Corp.

**Microsoft BASIC:** Microsoft Corporation

**WordStar:** MicroPro International Corporation

#### NOTICE

- All rights reserved. Reproduction of any part of this manual in any form whatsoever, without STAR's express permission is forbidden.
- The contents of this manual are subject to change without notice.
- All efforts have been made to ensure the accuracy of the contents of this manual at the time of going to press. However, should any errors be detected, STAR would be greatly appreciate being informed of them.
- The above notwithstanding, STAR can assume no responsibility for any errors in this manual.

©Copyright 1986 Star Micronics Co., Ltd.

# Table of Contents

<b>Chapter 1</b>	<b>Setting Up Your Printer</b>	<b>1</b>
	Locating the printer	
	Check the carton contents	
	Removing the printer cover	
	Removing the packing tube	
	Installing the ribbon cartridge	
	Installing the interface board	
<b>Chapter 2</b>	<b>Getting to Know Your Printer</b>	<b>7</b>
	Controls and parts of the printer	
	Parts of the printer	
	Controls and indicators	
	Extra functions	
	Other controls	
	Selecting and loading paper	
	Loading single sheets	
	Loading sprocket-feed paper	
	Adjusting the print head	
	Testing the printer	
	Connecting the printer	

<b>Chapter 3</b>	<b>Using the Printer with Commercial Software</b>	<b>21</b>
	Using commercial software	
	Word processing with the printer	
	General concepts	
	The escape code	
	The master reset code	
	Using Near Letter Quality (NLQ)	
	Getting the most from your print choices	
	Using the printer with EasyWriter II	
	Redefining pitch settings and print control codes	
	A sample printout with EasyWriter II	
	Redefining your own print pitches	
	Redefining your own print control keys	
	Using the printer with WordStar	
	User-defined print commands	
	Using the printer with Lotus 1-2-3	
	Using the panel modes	
	Advanced panel functions	
	Setting print start position	
	Setting the top of form	
	Setting the left and right margins	
<b>Chapter 4</b>	<b>Printing with BASIC</b>	<b>37</b>
	Some basics of BASIC	
	First steps	
	ASCII codes and the CHR\$ function	
	Control codes	
	The escape codes	
	A note on command syntax	
	Selecting the right software mode	
	Some special kinds of text	
	Near Letter Quality characters	
	Italic printing	
	Underlining	
	Superscripts and subscripts	
	Changing the print pitch	
	Expanded print	
	Condensed print	
	Proportional printing	
	Making words stand out	
	Mixing print modes	

<b>Chapter 5</b>	<b>Formatting Text</b>	<b>55</b>
	Lines and line spacing	
	Starting a new line	
	Reverse line feeds	
	Changing the line spacing	
	Moving down the page without a carriage return	
	Page control	
	Form feed	
	Reverse form feed	
	Changing the page length	
	Top and bottom margins	
	Setting left and right margins	
	Horizontal and vertical tabs	
	Horizontal tabs	
	One-time horizontal tabs	
	Vertical tabs	
	Vertical tab channels	
	Centering and aligning text	
<b>Chapter 6</b>	<b>Special Features of the Printer</b>	<b>77</b>
	Now hear this	
	Resetting the printer	
	Taking the printer off line	
	Printing the bottom of the sheet	
	Backspace, delete, and cancel text	
	Printing zeroes	
	Immediate-print	
	Adjusting the width of space between characters	
	Uni-directional printing	
	The seven bit dilemma	
	Block graphics characters and special symbols	
	International character sets	
	Printing characters in the control code area	
	Printing BIG characters	
	The optional sheet feeder	
	The macro control code	
	Reading a hex dump	

<b>Chapter 7</b>	<b>Download Characters and Dot Graphics</b>	<b>97</b>
	Dot matrix printing	
	Designing your own characters	
	Defining proportional characters	
	Designing your own NLQ characters	
	User-designed Dot Graphics	
	Higher resolution graphics	
	More graphics programming tips	
	Redefining alternate graphics codes	
	9-pin graphics mode	
<b>Chapter 8</b>	<b>Caring for Your Printer</b>	<b>115</b>
	Cleaning the printer	
	Replacing the ribbon	
	Replacing the print head	
<b>Appendix A</b>	<b>DIP Switch Settings</b>	<b>121</b>
	Switch functions	
<b>Appendix B</b>	<b>ASCII Codes and Conversion Chart</b>	<b>125</b>
<b>Appendix C</b>	<b>Function Codes</b>	<b>133</b>
	Commands to control print style	
	Font style controls	
	Font pitch controls	
	Special print modes	
	Controlling the vertical print position	
	Line feed and reverse line feed	
	Form feed and related commands	
	Top/bottom margins and vertical tabs	
	Controlling the horizontal print position	
	Download character commands	
	Dot graphics commands	
	Macro instruction commands	
	Other commands	
<b>Appendix D</b>	<b>Command Summary in Numeric Order</b>	<b>179</b>
<b>Appendix E</b>	<b>Technical Specifications</b>	<b>183</b>
<b>Appendix F</b>	<b>The Parallel Interface</b>	<b>187</b>
	Functions of the Connector Signals	

<b>Appendix G</b>	<b>Serial Interface Specifications</b>	<b>191</b>
	Configuring the serial interface	
	The serial protocols	
	Serial busy protocols	
	XON/XOFF protocol	
	ACK protocol	
<b>Index</b>		<b>196</b>





---

---

# CHAPTER 1

# SETTING UP YOUR

# PRINTER

---

---

**Subjects covered in Chapter 1 include—**

- **Choosing a suitable place for your printer**
- **Unpacking**
- **Setting up**

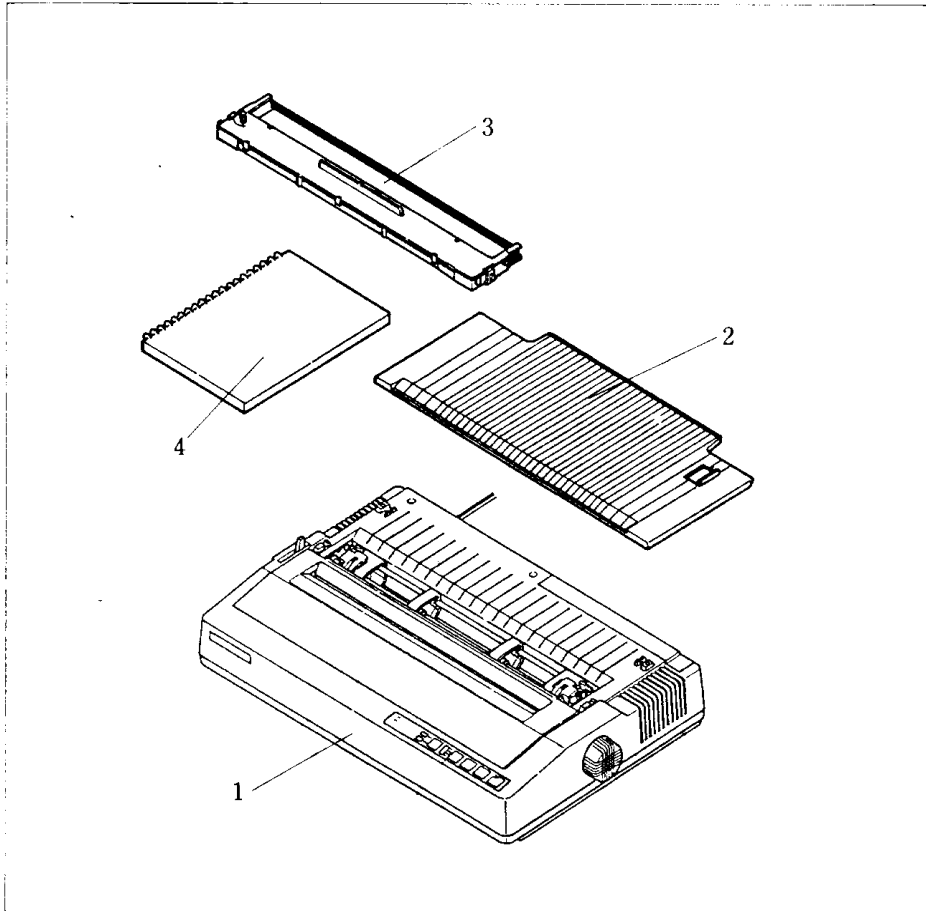
## **LOCATING THE PRINTER**

Give some thought to the best place to put the printer. Both the printer and computer should be used in normal office surroundings. For best performance, we recommend:

- Use the printer on a flat surface.
- Keep it out of direct sunlight and away from heat-producing appliances.
- Use it only in temperatures where you are comfortable.
- Avoid locations with dust, grease, or high humidity.
- Supply it “clean” electricity. Don’t connect it to the same circuit used by large, noise-producing appliances (such as refrigerators).
- Make sure the line voltage is within 10% of the voltage specified on the identification plate.

## **CHECK THE CARTON CONTENTS**

Open the carton and check each item in the box against Figure 1-1 to make sure that you have everything (there should be four items).



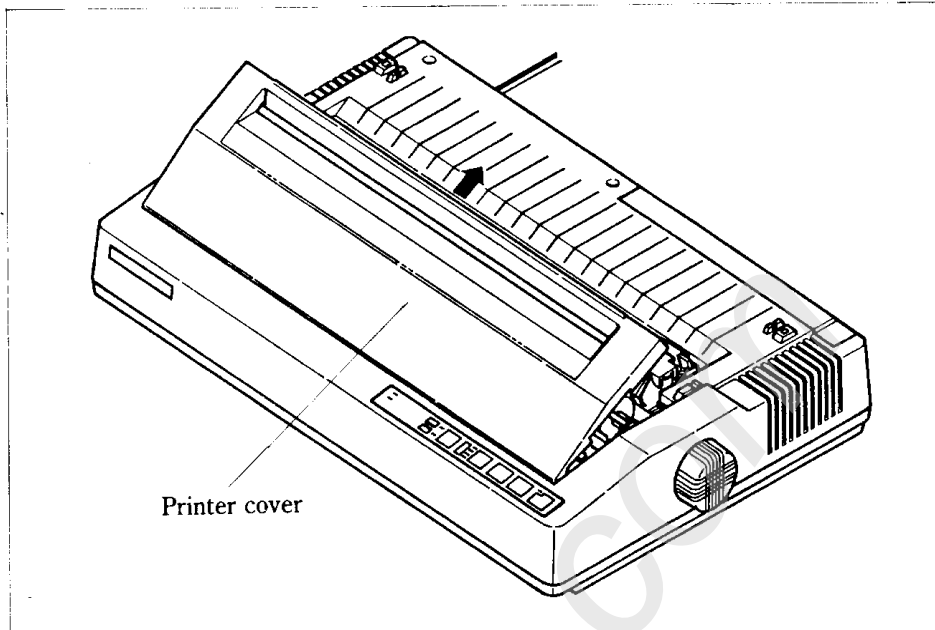
**Figure 1-1.** Check to make sure you have all four items: 1) printer, 2) paper guide, 3) ribbon cartridge, and 4) user's manual.

You should also have a parallel interface board to connect your computer to the printer. Also available are a parallel interface board with extra buffer memory and a serial interface board, both optional. (More on interfaces later.)

#### ■ Removing the printer cover

The printer's cover is important for two reasons — it keeps dust and dirt away from the printer's delicate mechanism, and it absorbs nearly all of the printer's operating sounds. Don't take off the cover unless you have to change the ribbon or make an adjustment.

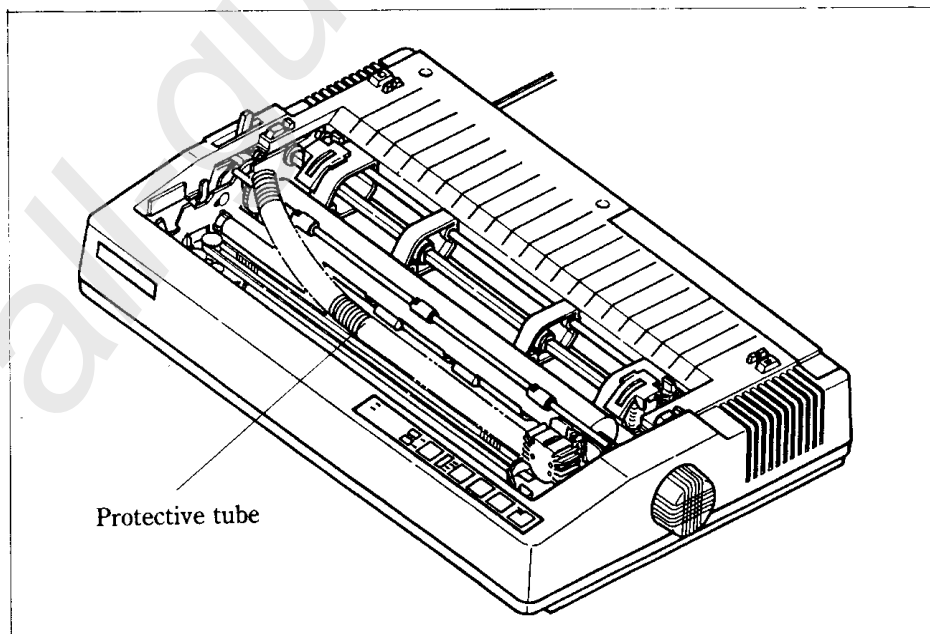
To remove the cover, lift up the back of the cover to disengage the three tabs at the front, then lift it off the rest of the way. To replace the cover, slide the tabs in at the front and lower it into place. Figure 1-2 shows the proper position and movement for both removing and replacing the cover.



**Figure 1-2.** Remove the printer cover by lifting carefully.

■ Removing the packing tube

The printer is shipped with a protective spiral tube to keep the print head from being damaged during shipping. This tube must be removed before use. First, take off the printer cover. The protective tube is split along its bottom side to allow easy removal. Grasp one end of the spiral tube and firmly pull it upward and away from the carriage rail.

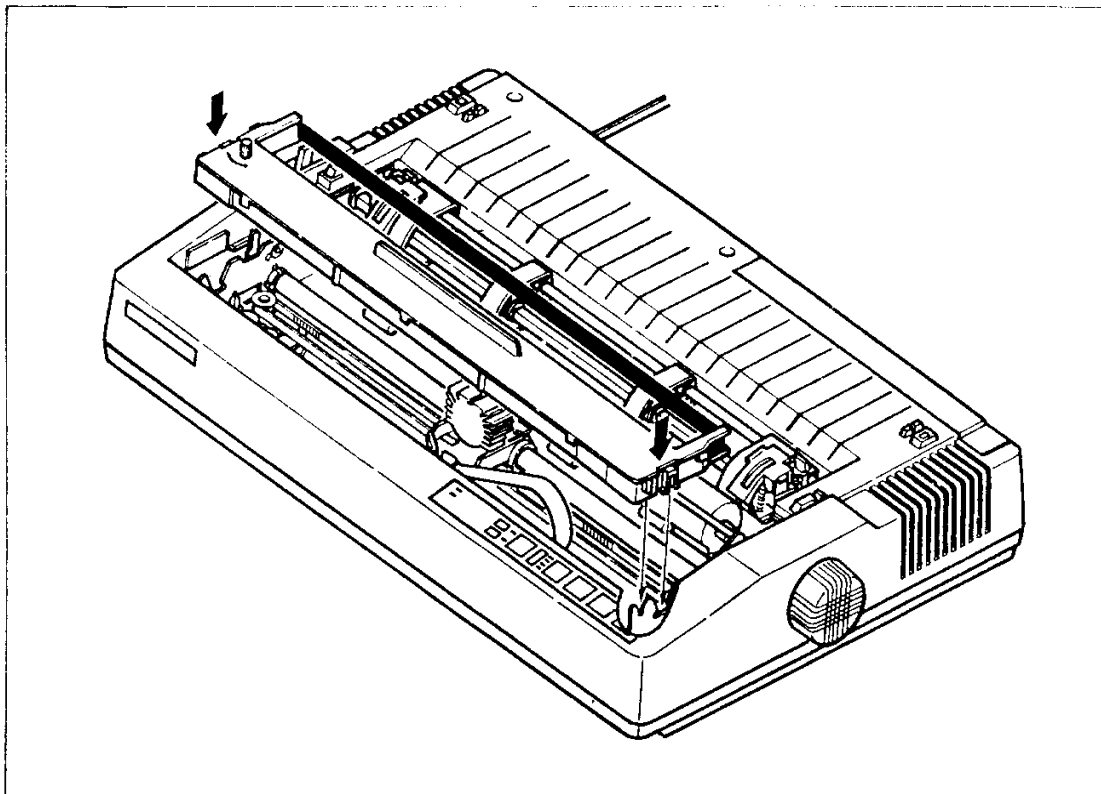


**Figure 1-3.** Remove the protective tube from the carriage rail.

## ■ Installing the ribbon cartridge

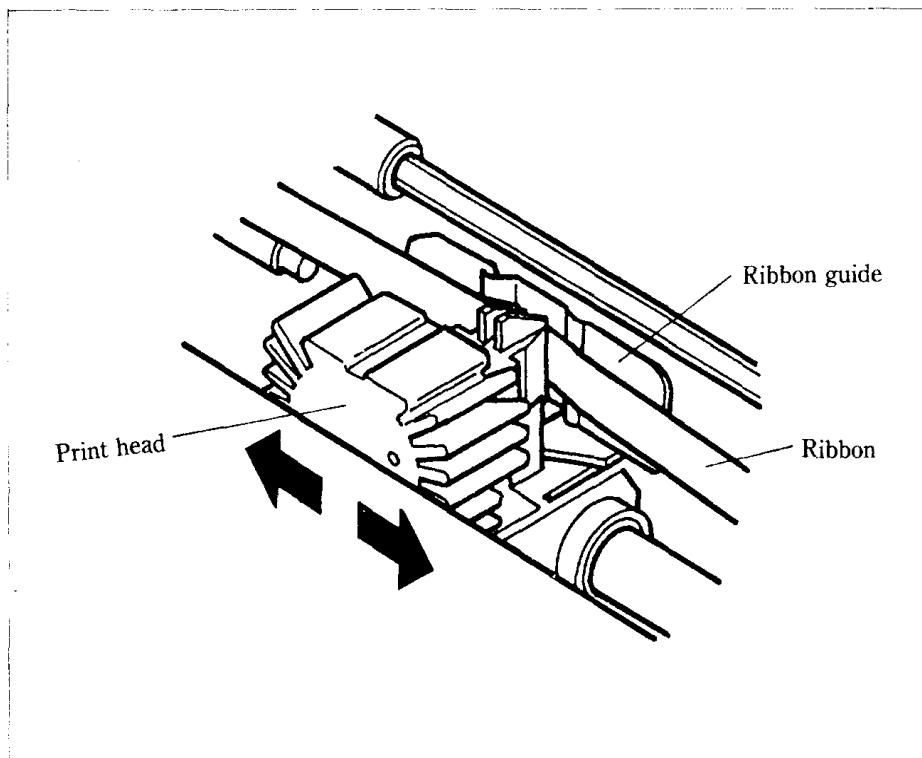
This printer uses a neat, easy-to-change ribbon cartridge with automatic threading. To fit or change the ribbon cartridge:

1. Turn *off* the power and remove the printer cover.
2. Slide the print head gently to the center of the printer.  
**Warning:** The print head gets hot during operation, so let it cool off before you touch it.
3. Set the release lever to either single sheet (■) or sprocket-feed paper (■).
4. With the ribbon facing away from you, use the guide holders as a fulcrum, and lightly press the cartridge down until the two holder springs snap shut to hold the cartridge firmly in place. See Figure 1-4.



**Figure 1-4.** Press the cartridge into place until the holding springs snap into place.

5. Check that the cartridge fits so that the drive pins engage the cartridge teeth, by turning the ribbon advance knob. Advance the ribbon to take up any slack.
6. Gently slide the print head carriage manually all the way to your right or left until the ribbon automatically slips down into its proper place between the print head



**Figure 1-5.** To thread the ribbon, slide the print head carriage manually to the right or left, and the ribbon will slip down by itself into its proper position.

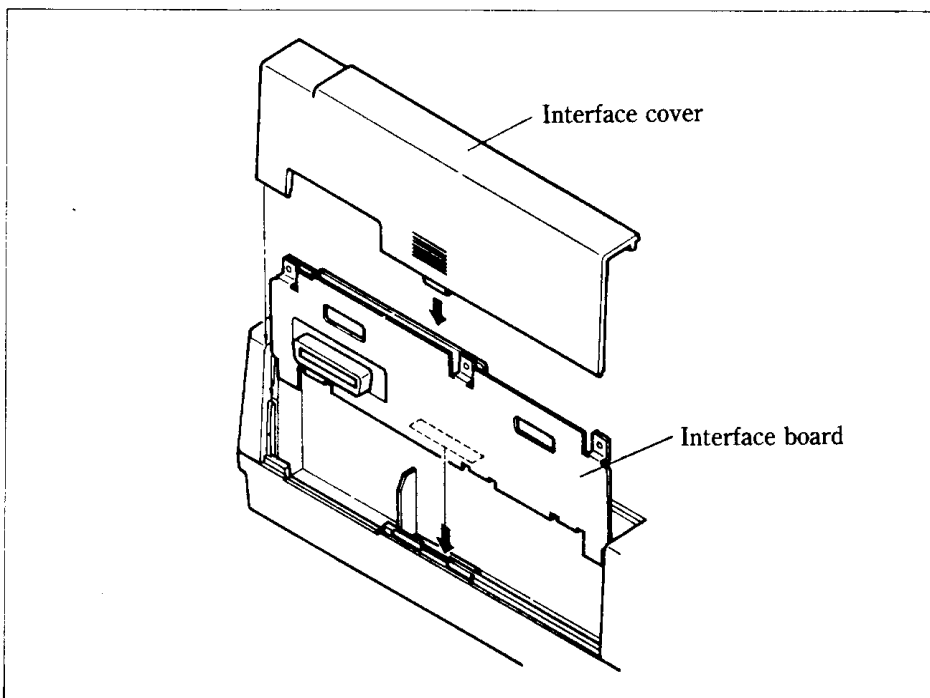
7. Replace the printer cover. (A switch on the printer prevents the printer from operating when the cover is off.)

#### ■ Installing the interface board

A parallel interface board comes standard with your printer. In addition, there are two optional interface (I/F) boards: a serial interface board that lets you connect to a serial (RS-232C) computer port; and the other board contains extra buffer memory for parallel output. All three boards are installed the same way.

To install or change an I/F board, turn off the power and turn the printer around. Notice the snap-on cover at the left end. Take it off by sliding it upwards.

Fit the I/F board into the side slots and slide it all the way down (don't force it). Make sure that the board connector is seated snugly in its socket. Put the cover back on and connect the cable from your computer — you're ready to go.



**Figure 1-6.** Slide the I/F board into the slot.

---

---

# CHAPTER 2

## GETTING TO KNOW YOUR PRINTER

---

---

**Subjects covered in Chapter 2 include—**

- **Parts of the printer – what they're for and how to use them**
- **Paper selection and loading**
- **Adjustment**
- **Testing printer operation**

### **CONTROLS AND PARTS OF THE PRINTER**

#### ■ **Parts of the printer**

**PRINTER COVER** — This protects the ribbon and the print head from dust and dirt, and cuts down the sound of the printer.

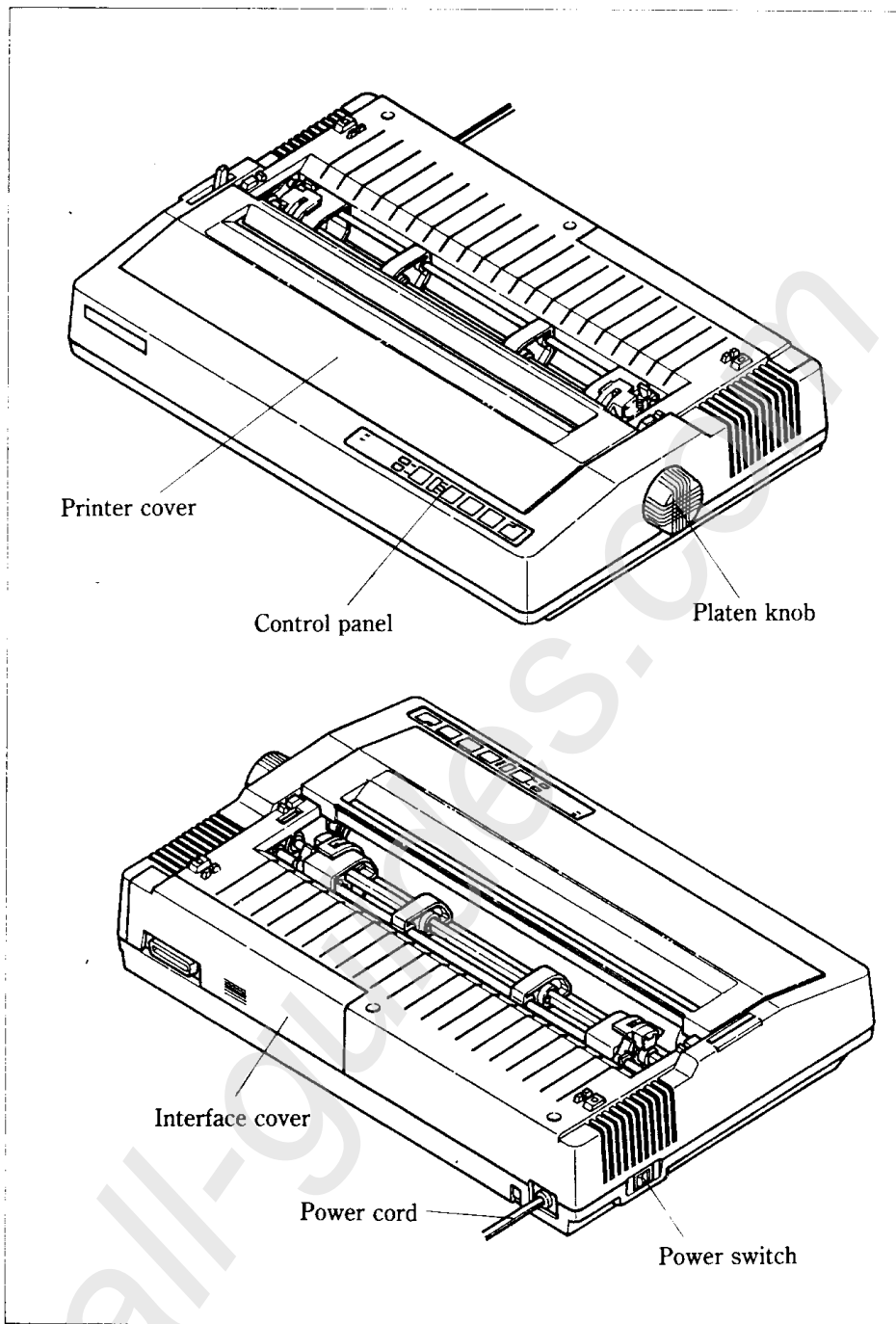
**PAPER GUIDE** — This flat plastic molding guide has two functions, depending on what kind of paper you are using. If you are using single sheets, the guide is propped up on top of the printer, and serves as a guide. If you are using sprocket-feed paper, the guide is reversed and laid flat on top of the printer, and serves as a paper separator.

**POWER CORD** — This cord connects the printer to its power source, usually a wall outlet. It's located at the left rear of the printer.

**PRINT HEAD** — This is the device that does the actual printing. Like the strike lever in a typewriter, tiny pins in the print head hit the paper through a ribbon.

**TRACTOR FEED UNIT** — The drive gear and sprockets of the tractor feed unit move sprocket-feed paper through the printer.

**PLATEN** — This is the rubber cylinder that carries paper to the print head.



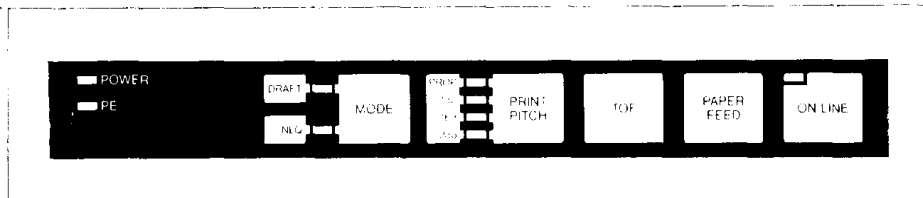
**Figure 2-1.** Front and rear views of the printer.

**INTERFACE COVER** – On the back of the printer, this cover conceals and protects the interface board. The cover is cut away to expose the external connector to which you attach your computer cable.



## ■ Controls and indicators

Now let's go over the controls and indicators of the printer, starting with the control panel on the right. There are nine indicators and five keys on the control panel.



**Figure 2-2.** The control panel.

**POWER INDICATOR** – Glows green when the power is *on*.

**PE INDICATOR** – Stands for “Paper Empty”, and glows red when the printer runs out of paper and when certain printer malfunctions occur.

**MODE INDICATORS** – Either DRAFT or NLQ glows green to indicate the mode (set by the Mode key or the DIP switch).

**MODE KEY** – Changes the print mode every time it is pressed when the On Line indicator is off.

**PITCH INDICATORS** – Shows the character pitch currently set: Proportional (PROP), Pica (136 characters/line), Elite (163 characters/line), or Pica condensed (233 characters/line).

**PRINT PITCH KEY** – Selects one of the four available character pitches when the On Line indicator is off.

**TOF KEY** – Ejects the current sheet, feeds a new sheet, and moves the print head to the left margin when the On Line indicator is off.

**PAPER FEED KEY** – Advances the paper one line at a time when the On Line indicator is off. If you hold the key down, you get consecutive line feeds.

**ON LINE KEY and INDICATOR** – Glows green when the printer is ready to receive data from your computer (on line). When the printer is off line, it sends a signal to the computer indicating that it cannot accept data. Pressing the On Line key switches the printer between on line and off line. When you turn the power switch on, the printer is placed on line automatically.

### ■ Extra functions

There are eleven more functions that are not directly specified on the control panel. You can access six of them by pressing one particular key when you turn on the power; five others are activated by pressing two control keys at once.

For details, please refer to the end of next chapter.

### ■ Other controls

There are other controls, not connected to the control panel. Some of the more important ones are:

**POWER SWITCH** — The switch that turns the printer on and off is at the back, on the left side.

**PLATEN KNOB** — This knob is at the middle of the right side and lets you turn the platen by hand, like a typewriter.

*Caution:* Turn the platen knob only with the Power switch *off*.

Turning the knob with the power on could damage the drive gears.

**RELEASE LEVER** — The release lever is on top of the printer, near the left rear corner. It controls how strongly the paper is held against the platen. The release lever has four positions: the top setting is used for inserting paper, the next is for single sheets, the third is for sprocket-feed paper, and the bottom one is used when adjusting the paper.


**PAPER BAIL** — The bail is the movable bar that holds the paper against the platen. Its position depends on the setting of the release lever.

**DIP SWITCHES** — There are one set of ten switches and one set of six switches that are used in interfacing the printer to your particular computer. There are also switches to set page length, line spacing, and perforation skipping. See Appendix A for a complete list and explanation.

## SELECTING AND LOADING PAPER

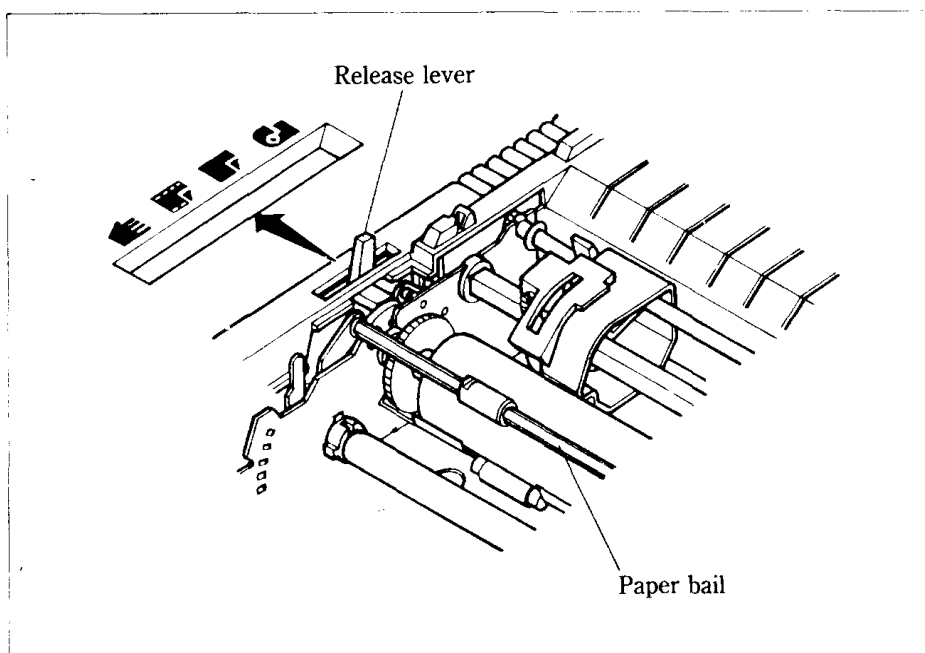
Your printer handles two basic types of paper — single sheets (stationery, envelopes, multipart business forms, etc.) and continuous paper (fan-fold perforated paper).

The release lever controls the pressure of the paper against the platen. It has four settings:

 — The top setting is used when you want to load paper in the printer.

- – The second setting is for normal single sheets.
- – The third is for sprocket-feed paper.
- – The bottom one is used when you want to release the paper completely to adjust it.

The paper bail holds the paper against the platen according to the setting of the release lever. The bail is opened when the release lever is in the top position, closed when the lever is in the second or third positions, and opened by the printer when the lever is in the bottom position.

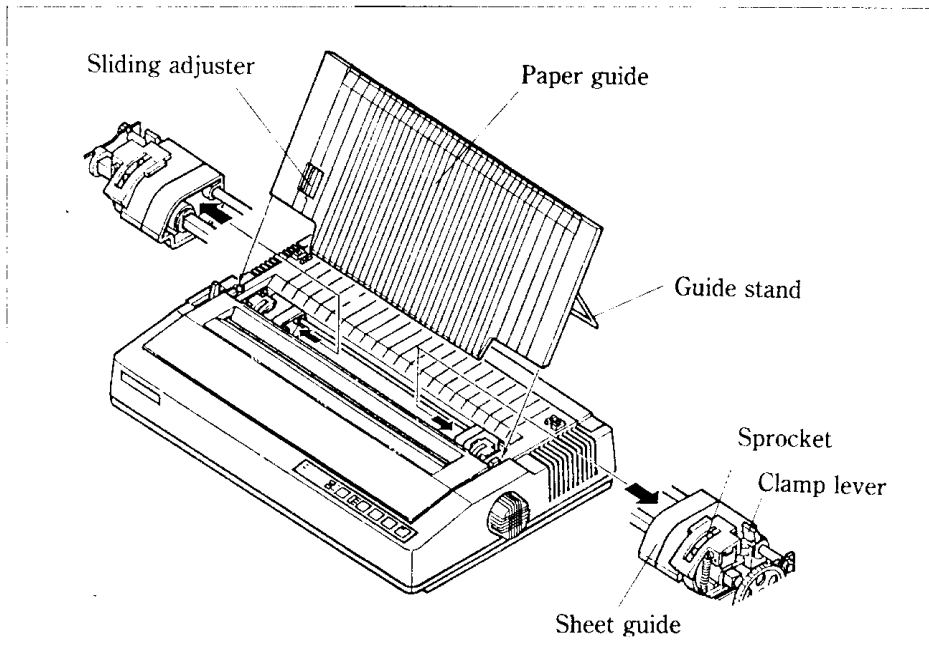


**Figure 2-3.** Use friction feed for single sheets and tractor feed for continuous paper.

#### ■ Loading single sheets

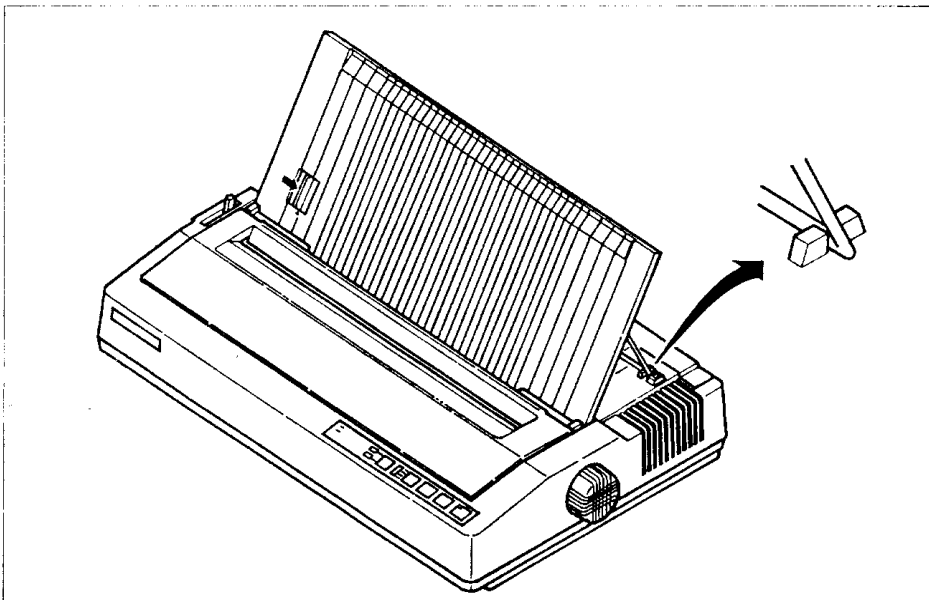
Instead of feeding the paper in *manually* by turning the platen knob, you can use the release lever for automatic feeding (the printer must be turned *on*). Single sheets from 6 to 14.5 inches wide can be used and the paper guide must be fitted:

1. Flip the clamp levers backward and move the sprockets and sheet guides on the tractor feed unit all the way to the ends.
2. With the ribs of the paper guide toward you and the sliding adjuster at the bottom left, insert the guide into the slot at the back of the printer cover.



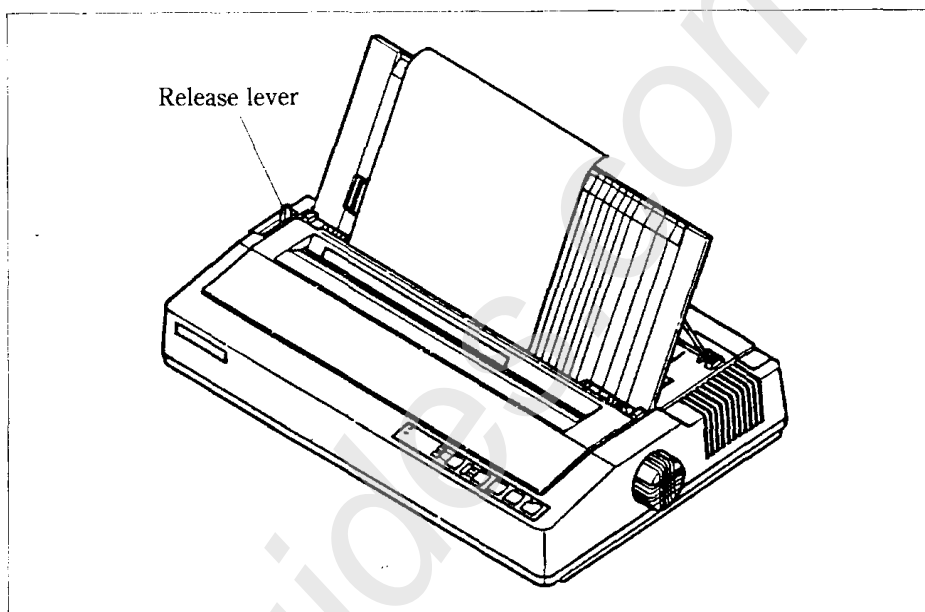
**Figure 2-4.** Raise the paper guide for loading single sheets.

3. Insert the guide stand in the notches provided for it and prop up the paper guide.
4. Position the adjuster at the triangle marked on the guide for standard margins, or set it according to your own requirements.
5. Set the release lever for single sheets — the second position from the top.



**Figure 2-5.** Prop up the paper guide by inserting the guide stand in the notches provided for it.

6. Align a sheet of paper on the guide along the adjuster.
7. Turn on the power switch. (The Paper Empty indicator will glow because there is no paper.)
8. Now set the release lever to the auto-feed setting — the top position. The printer will advance the paper automatically.
9. When the paper stops, set the release lever for single sheets again.



**Figure 2-6.** You can insert a sheet of paper automatically by using the release lever.

**To align paper that is not in straight—**

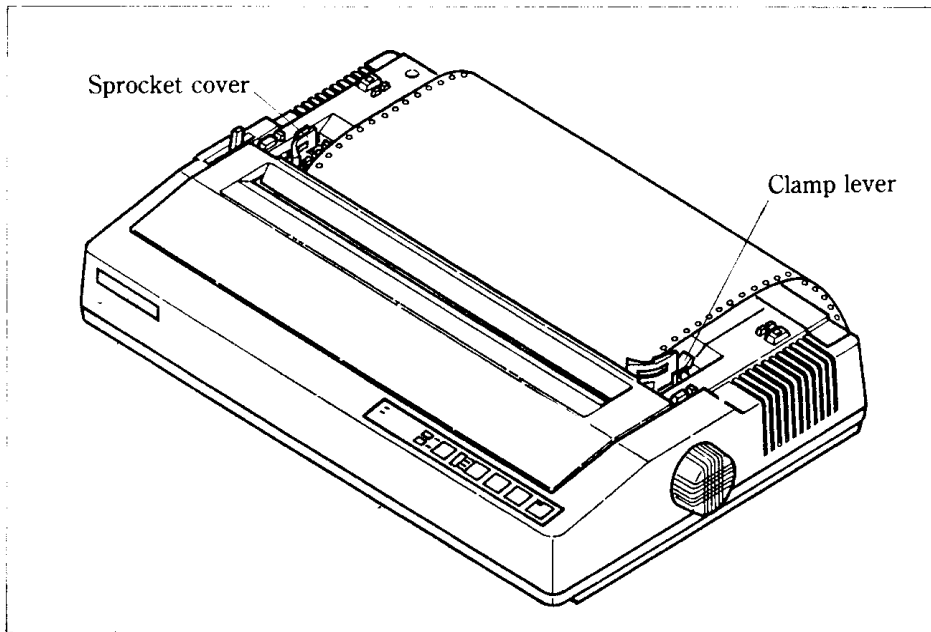
- Set the release lever to the adjustment setting.
- Straighten the paper and adjust it for the margins you want.
- Move the release lever back to its original setting.

Remember, you can also use the optional automatic sheet feeder for single sheets.

■ **Loading sprocket-feed paper**

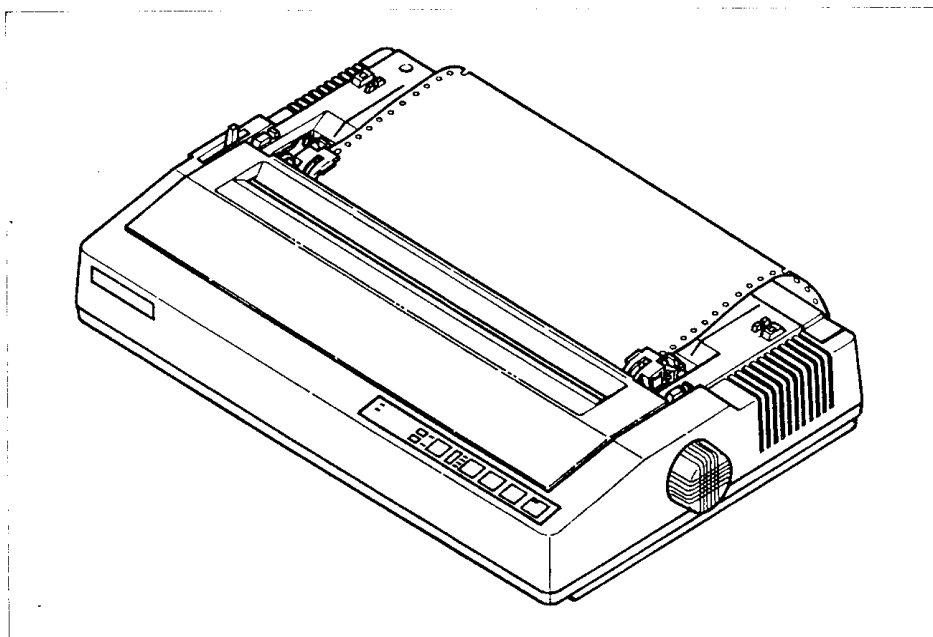
This is standard computer paper, with the holes along the sides and perforations between the sheets. It is also called sprocket, punched, fan-fold, or just plain “computer paper.” It can be as narrow as 4 inches, and up to 15.5 inches wide.

1. Turn on the printer and set the release lever for sprocket-feed paper.
2. If the paper guide is installed, remove it, and put it aside for a moment.
3. Place a stack of fan-fold paper behind the printer.
4. Open the sprocket covers, on the right and left sprocket units, as shown in Figure 2-7.

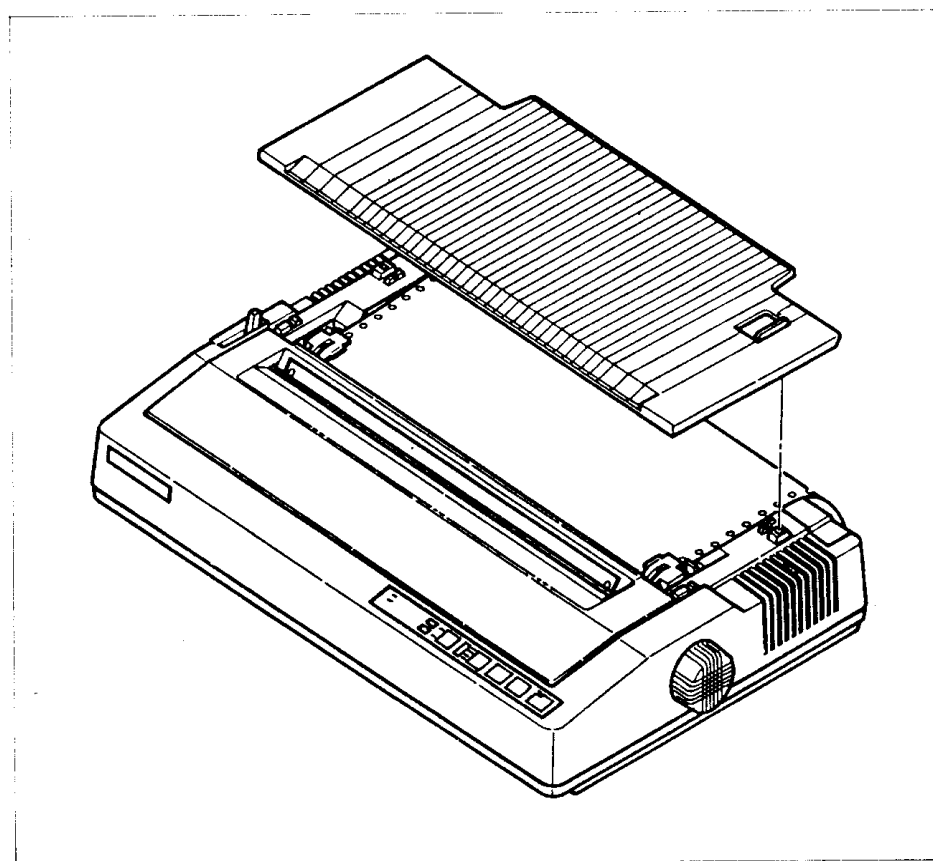


**Figure 2-7.** Open the sprocket covers to expose the sprocket teeth.

5. Flip the clamp levers backward. This allows the two sprocket units to move freely right and left so you can align them with the holes in the paper.
6. Feed the end of the paper into the slot next to the platen cover plate.
7. Fit the holes in the paper over the sprocket pins so the paper is even, and clamp the sprocket units in place.
8. Check that the paper is still positioned correctly, and close the sprocket covers (Figure 2-8).
9. Set the release lever to the auto-feed setting. The printer will advance the paper automatically.
10. When the paper stops, set the release lever for sprocket-feed paper again.
11. Install the paper guide on the printer. See Figure 2-9 for details. When used with sprocket-feed paper, the guide is turned around and laid flat on top of the printer as a paper separator. Make sure that the tabs on the guide fit into their receivers.



**Figure 2-8.** Close the sprocket covers when the paper is positioned correctly.



**Figure 2-9.** Ready to load the sprocket-feed paper. Note the reversed position of the paper guide.





lever (Figure 2-10). Pulling the adjustment lever towards you will widen the gap; pushing it away from you will narrow the gap.

There are four positions; you can feel the lever clicking into the various notches. The first step (shown) is the one most commonly used for single sheets of paper.

Try different positions until you get the best printing results.

## TESTING THE PRINTER

Your printer has two built-in programs that printout sample lines of letters, numbers, and other characters — to show you that everything's in good working order. Self-test 1 is the long version, and self-test 2 is the short one. You can use either one to show the characters available in the printer, to check the installation of the ribbon and paper, and to check the adjustment of the head-to-platen gap.

```

mnpqrsstuvwxvz(1)~
mnpqrsstuvwxvz(1)~
mnpqrsstuvwxvz(1)~
mnpqrsstuvwxvz(1)~
mnpqrsstuvwxvz(1)~
mnpqrsstuvwxvz(1)~
mnpqrsstuvwxvz(1)~

```

```

fg hijklmnpqrsstuvwxvz(1)~QüëäääçëëëiflAAEzEöóóúÿÜÜçE#Rfáíóú
ñ±±±fj±±±-v02±
fg hijklmnpqrsstuvwxvz(1)~QüëäääçëëëiflAAEzEöóóúÿÜÜçE#Rfáíóú
ñ±±±fj±±±-v02±
fg hijklmnpqrsstuvwxvz(1)~QüëäääçëëëiflAAEzEöóóúÿÜÜçE#Rfáíóú
ñ±±±fj±±±-v02±
fg hijklmnpqrsstuvwxvz(1)~QüëäääçëëëiflAAEzEöóóúÿÜÜçE#Rfáíóú
ñ±±±fj±±±-v02±
fg hijklmnpqrsstuvwxvz(1)~QüëäääçëëëiflAAEzEöóóúÿÜÜçE#Rfáíóú
ñ±±±fj±±±-v02±
fg hijklmnpqrsstuvwxvz(1)~QüëäääçëëëiflAAEzEöóóúÿÜÜçE#Rfáíóú
ñ±±±fj±±±-v02±

```

```

E1mnpqrsstuvwxvz(1)~"##%0123456789:;=>@ABCDEFGHI
lmnpqrsstuvwxvz(1)~"##%0123456789:;=>@ABCDEFGHI
mnopqrsstuvwxvz(1)~"##%0123456789:;=>@ABCDEFGHI
nnpqrsstuvwxvz(1)~"##%0123456789:;=>@ABCDEFGHIJK
opqrsstuvwxvz(1)~"##%0123456789:;=>@ABCDEFGHIJKL
pqrstuvwxvz(1)~"##%0123456789:;=>@ABCDEFGHIJKLM

```

You can print the self-test without hooking up the printer to your computer. Simply:

1. Plug in the printer (don't turn it on yet).
2. Insert a sheet of paper (or sprocket paper, either one).
3. While holding down one of the following keys, turn on the power switch:

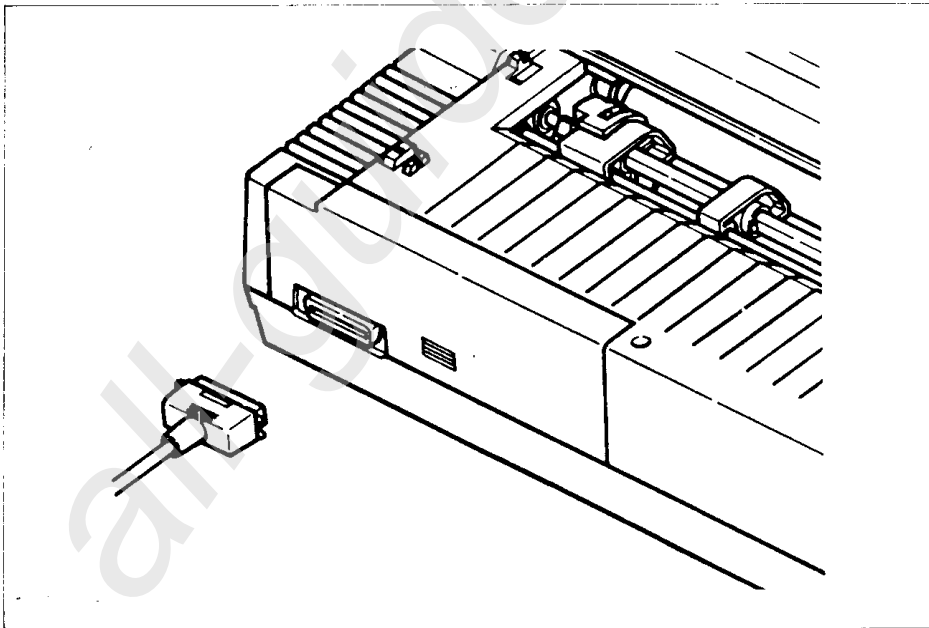
Paper Feed key – Self-test 1 (long)

On Line key – Self-test 2 (short)

When you want to terminate the long self-test function, turn off the power switch.

## CONNECTING THE PRINTER

Now that you've assembled and tested your printer, all that remains is to connect it to your computer as follows:



**Figure 2-12.** Connect the cable like this.

1. Make sure that both your computer and printer are turned off.
2. Connect the printer end of the interface cable to the connector socket at the right rear of the printer as shown in Figure 2-12.
3. Connect the other end of the cable to your computer as described in the computer manual.

**MEMO**

---

---

# CHAPTER 3

## USING THE PRINTER WITH COMMERCIAL SOFTWARE

---

---

Subjects covered in Chapter 3 include—

- Using commercial software
- Controlling the printer with the Panel mode

### USING COMMERCIAL SOFTWARE

Many of you purchased this printer to use with commercial software. You made a good choice because this printer is compatible with most commercial programs, from word processing programs to spreadsheet programs to accounting programs.

Many of these programs have a routine for describing your printer. These routines are often in “installation programs”. They typically give you a choice of printers or printer types to pick from. Some typical descriptions that you might pick for this printer are: “TTY type printer with backspace”, “IBM-dot matrix printer”, “Centronics-type printer”, “Dot matrix ASCII printer” or “Epson FX series”. This printer should work fine with any of these descriptions.

Some printer lists are not very clear, and may not include anything that you think describes this printer. If you can't decide which description best fits this printer, we recommend that you narrow the list to two or three choices (you can quickly eliminate all the daisy-wheel printer types) and then experiment. You won't hurt anything if you guess wrong; it just won't work correctly. This should quickly tell you if your guess is right. If all else fails, though, your printer dealer will be happy to give you some advice.

Some programs don't ask you what kind of printer you have, but instead ask some questions about what your printer can do. The answers to the “most asked” questions are: Yes — this printer *can* do a “backspace”, and this printer *can* do a “hardware form feed”.

With these questions answered, you are ready to start printing. Read the manual that came with your commercial software and the next Chapter to see how to make it send information for this printer to print. This is all you need to know to use this printer as a regular printer. But this printer isn't just a regular printer. This printer has many capabilities that your commercial software isn't aware of. We will see what it takes to use some of the printer's advanced features with commercial software in the next section.

## **WORD PROCESSING WITH THE PRINTER**

Not many word processing programs directly support all of the advanced features of printers. They usually provide a method for using a few of the more common print features such as boldface and underlining. But as you are probably beginning to see from this manual, this printer can do much more than that.

As a result, most word processing programs provide a way of sending special codes to a printer. The actual codes used (as well as the method of entering them) will vary different software. The theory behind these methods, however, is basically the same.

This section discusses two word processing programs and one spreadsheet program most used by printer owners. The programs also provide a variety of ways to enter the codes necessary to use the advanced features of this printer. These concepts can be applied to many other programs besides those detailed here. The programs are:

EasyWriter II

WordStar

Lotus 1-2-3

If your software program is not included in this Chapter, you should still study the different techniques used. Then, with the help of your program manual and the supporting chapters in this manual, you should be able to figure out how yours works.

## **GENERAL CONCEPTS**

Each word processing program has a way to get out of the

standard text entry mode in order to accept the special printer function codes. WordStar uses the CONTROL key in different ways to define the print function codes.

EasyWriter II has a system function which allows you to define print pitches and special print functions for use with the ALT key.

Your word processing User Manual (if it supports this process) will have a section describing how to get out of the standard program. You will probably have to figure out on your own which codes are used. The general concepts and details of the two sample programs should be enough to help you be successful.

#### ■ The escape code

Most of the special print functions start with a code called the escape code. It can be entered in decimal or hexadecimal values, by an ASCII character, or by using the control keys on your keyboard, depending on which program and which computer you are using.

The escape code tells the printer to interpret the values (or characters) following it as printer functions. The codes used to describe the functions are also entered in the same way as the escape code. In this section, we will show you the format each word processor uses as well as the general rules to correctly entering the function codes.

The next chapter covers how to convert the different forms of ASCII codes. You should review Chapter 4, if you have not already done so, before working with the function codes.

#### ■ The master reset code

There is one function code which turns off all the print functions currently being used by the printer. It is called the master reset code and resets the printer to its DIP switch settings. These print characteristics are the same as the ones used by the printer when it is first turned on.

The code sequence for master reset is `<ESC> "@"`. By checking the ASCII equivalents in Appendix C, you can see that the decimal expression is 27 64. You'll see these numbers several times in this section.

Technically speaking, initializing the printer clears the print buffer, and the form length, character pitch, character set, line feed pitch and international character set are all reset to the

values defined by their respective DIP switch settings.

We suggest you get in the habit of using the master reset code in any document where you use function codes. If you do not, the printer will keep the most recently defined characteristics, and print any following documents the same way.

You could turn your printer off each time (which also resets the default settings) but that would be hard on the printer circuits. Also, you'll save time and paper by letting the printer automatically reset with this code. (If you need more information on DIP switch settings for your printer, please refer to Appendix A.)

### ■ Using Near Letter Quality (NLQ)

With near letter quality, the printer prints more dots for each character than with the draft printing. This process results in a higher quality look to your text. Draft quality characters print much faster, so use them for your first drafts and use near letter quality for a professional looking finished manuscript.

The escape code sequence to turn the NLQ set on is `<ESC> "x" 1` and the code sequence to select draft quality is `<ESC> "x" 0`. The decimal equivalents are 27 120 1 and 27 120 0, respectively.

### ■ Getting the most from your print choices

After working with the printer for a while, you may find that you want to add or change some of the print functions we have described in this chapter.

We suggest you do three things. First, you should review Chapter 4 and Appendix C to become as familiar as possible with ASCII codes and the function codes.

Second, read Chapter 4 which describes them in greater detail and shows examples of how they are used in BASIC programming. The functions will, for the most part, act the same in your word processing program. Understanding what's available and how they perform will help you use them correctly in your documents.

And third, follow the procedures in this chapter and your program User's Manual.

You may want to experiment with expanded text in combination with other print types. You can create some great-looking results with these functions. If you are unsure of any functions, review them first, then try some of your own samples.



## USING THE PRINTER WITH EASYWRITER II

(Note: If you have not read the “General Concepts” section in this chapter, you should do so before continuing.)

This printer can be used with most of the standard print functions available with your EasyWriter II word processing program. These functions require no special adjustments to the printer or your program. They include:

1. Printing from the Print List Form screen.
2. Setting margins, tabs and lines per inch in the ruler line of your document. (The pitch settings, however, should be adjusted to obtain maximum use. They will be discussed later in this chapter.)
3. Print settings in the System Parameter function which are either default or new settings edited by you.

You can also redefine the print functions of EasyWriter II to take advantage of many of the printing capabilities of your printer. You may already be familiar with reconfiguring the printer driver from Appendix B of your EasyWriter II User's Manual. If not, don't be nervous; it's not as hard as it sounds. We will show you how to make changes in your program specifically to help you print with this printer.

By changing the pitch settings, you can use the document ruler line to print pica, elite and condensed width pitches. In addition, you can use a similar method to print in near letter quality.

The print control codes can be redefined to enhance the final product of your document. The boldface, underline, superscript and subscript functions require only a slight “recoding” of information in the printer driver. And we have some suggestions for changing the characteristics of the other print control codes to use italic, expanded, emphasized and italic-underline print. With these options, you will have even more flexibility printing with this printer.

### ■ Redefining pitch settings and print control codes

In order to change the settings used in the document ruler line and the print control codes, it is necessary to edit ASCII code decimal values in the System Functions portion of your EasyWriter II program. (For more details about ASCII codes, please refer to Chapter 4.)

Your printer is considered a Type B printer by the

EasyWriter II program. Before making any changes in the printer driver, you should first check to be sure the printer selection is set for printer Type B (Option 7 on the System Functions menu.)

Then follow the instructions in Appendix B of your EasyWriter II User's Manual to reconfigure Type B printers. To become more familiar with the reconfiguration process and its terms and to make the instructions in this section easier to understand, we suggest you read through Appendix B first.

In these few paragraphs, we'll show you the ASCII decimal values we feel provide good flexibility in printing with this printer. You should follow the instructions hands-on with your own EasyWriter II program.

The changes you will make are for pitch settings and print control codes (also called font support). However, all the screens involved will be explained as you see them displayed.

From the System Functions Menu, choose Option 9 (Reconfigure Printer Type B) and the printer name will be displayed. Type over the present printer name as follows:

1. Printer Name [ *Dot Matrix Printer* ]

Press RETURN and the Edit Global Sequences screen will be displayed. These codes control the print functions for form feed, line feed, margin settings and automatic justification. We do not recommend that you edit any of these codes.

Press RETURN and the Edit Pitch Table screen will be displayed. On this screen, you will enter the ASCII decimal values to define the print pitches. The first two fields in each line define the pitch range (which in this case are both the same number). They should be assigned as follows:

10 = Pica	1 = Near Letter Quality On
12 = Elite	2 = Near Letter Quality Off
17 = Condensed Pica	3 = Master Reset Code

On this screen, the column labeled "Sequence" is used to define the print functions in their ASCII decimal values. For these print pitches, we will use a combination of codes to turn near letter quality on and off and to choose the function code for each pitch. (For more details on function codes, please refer to Appendix C.)

Follow the sample and enter the (italic) codes for lines 17 - 22.

```

17. [10 ] [10 ]      { 18 27 80      }
18. [12 ] [12 ]      [ 18 27 77      ]
19. [17 ] [17 ]      [ 15                ]
20. [1  ] [1  ]      [ 27 120 1          ]
21. [2  ] [10 ]      [ 27 120 0          ]
22. [3  ] [3  ]      [ 27 64             ]
23. [120] [120]      [                ]
24. [120] [120]      [                ]
25. [120] [120]      [                ]
26. [120] [120]      [                ]

```

The codes 120 in lines 23 through 26 can be changed to reflect more pitch settings. We recommend that until you are more familiar with using special function codes, you use just the six we have defined.

When you have finished, press RETURN. You will be transferred to the Edit Line Spacing screen. Do not change these codes. They define how many lines per inch the printer uses. Press RETURN to transfer to the Edit Font Support screen.

Change all of the entry fields to Option 2 (Control Code Support) on the Edit Font Support screen. Also, make changes in the other fields to look like the figure shown below. Enter the (italic) codes for lines 41 - 50.

```

41. Bold/Shadow Face Support [2]
42. Single Underline Support [2] Using Character [95 ]
43. Double Underline Support [2] Using Character [0  ]
44. Overstrike Support      [2] Using Character from
45. Special (Color) Support [2] System Parameters
46. Sub/Superscript Support [2]
47. Will underline retain font (Y) or be normal font (N)?
    [N]
49. Start double underline [    ]
50. After double underline [    ]

```

When you have finished, press RETURN and the Edit Font Sequences screen will be displayed. Here you will define print control codes for use in your documents. As with the pitch settings, ASCII decimal values are used that correspond to the

print function assigned to each control key. Table 3-1 shows the current control function, the print function we will assign to it and the keyboard keys used.

**Table 3-1**  
**EasyWriter II control keys**

EasyWriter II Function	New function	Keys used
Boldface	Boldface	ALT & B
Shadow	Italic	ALT & S
Underline	Underline	ALT & _
Double	Expanded	ALT & =
Overstrike	Emphasized	ALT & O
Special	Italic Underline	ALT & *
Subscript	Subscript	ALT & D
Superscript	Superscript	ALT & U

Enter the (italic) codes for lines 51 - 66.

```

51. Normal to Bold      [ 27 71      ]
52. Bold to Normal     [ 27 72      ]
53. Normal to Shadow   [ 27 52      ]
54. Shadow to Normal   [ 27 53      ]
55. Normal to Underline [ 27 45 1    ]
56. Underline to Normal [ 27 45 0    ]
57. Normal to Double   [ 27 87 1    ]
58. Double to Normal   [ 27 87 0    ]
59. Normal to Overstrike [ 27 69      ]
60. Overstrike to Normal [ 27 70      ]
61. Normal to Special   [ 27 52 27 45 1 ]
62. Special to Normal   [ 27 53 27 45 0 ]
63. Normal to Subscript [ 27 83 1    ]
64. Subscript to Normal [ 27 84      ]
65. Normal to Superscript [ 27 83 0    ]
66. Superscript to Normal [ 27 84      ]

```

When you have finished, press RETURN. You're done! You will be transferred out of the Reconfigure Type B Printer function and back to the System Functions Menu.

#### ■ A sample printout with EasyWriter II

Let's look at a short example to demonstrate how pitch settings and print control keys can be used in a document. The ex-

ample below shows the use of expanded and italic prints used in combination with condensed and pica pitch settings. Use your EasyWriter II program hands-on and type the example below.

SUBJECT: ORDERING STATIONERY SUPPLIES

I would like to place an order for stationery supplies from your mail order catalog. Enclosed is my order form and a check for \$247.67. Please process this order as soon as possible. Thank you.

With the cursor under the "S" in "SUBJECT", set the print pitch in the ruler line to condensed width pitch. Name the ruler line "condensd" (without the quotes) and change the character pitch to 17 and the line spacing to 6. To make the subject title expanded, use the ALT and = keys (in the line mode) to highlight the line.

Now, change the pitch setting in the next line to pica by setting a new ruler line: Ruler Name - pica; Character Pitch - 10. Use the print control key S (for italic) to highlight the second sentence in the paragraph. Move the cursor to the "E" in "Enclosed" and (in the sentence mode) use the ALT and S keys to highlight the sentence. (You'll have to press S twice to get the .67.)

At the end of the document, reinitialize the printer to its default settings with a new ruler line using the Master Reset code. Ruler Name - reset; Character Pitch - 3.

Print the document. Your printout should look like this:

SUBJECT: ORDERING STATIONERY SUPPLIES

I would like to place an order for stationery supplies from your mail order catalog. *Enclosed is my order form and a check for \$247.67.* Please process this order as soon as possible. Thank you.

The subject title will print in expanded condensed characters which are twice the width as standard condensed characters. The sentence in the paragraph is printed in italic pica print. The last ruler line will reinitialize the printer. (See the general concepts section for more details on master reset.) This is just one

example; you should be able to apply most of the function codes to the setup used here.

#### ■ Redefining your own print pitches

If you want to define a new print pitch (Edit Pitch Table), enter your function code to choose the print you want.

For example, if you find yourself frequently using italic print for large blocks of text in pica pitch, you can combine italic and pica pitch to define italic pica and use it in the ruler line of your document. The ASCII code sequence would be 27 80 27 52 to print italic pica pitch.

#### ■ Redefining your own print control keys

The ASCII codes to redefine the print control keys (Edit Font Sequences) are pretty straightforward. There are individual ASCII decimal values to turn on and off different prints. You want to affect that aspect but not the print pitch itself. Leave that for your document ruler line. Remember, all the codes can be found in Appendix C of this manual.

Also, keep in mind that print control keys can be combined in your document such as boldface and underline. EasyWriter II uses three methods of highlighting on the display screen. It highlight, underlines and shows reverse image characters. You cannot combine print control functions that use the same method of highlighting.

For example, in our definitions, underline and expanded prints are both displayed as underlined on the screen. Whichever function you use last will cancel out any previous modes.

## USING THE PRINTER WITH WORDSTAR

(Note: If you have not read the "General Concepts" section in this chapter, you should do so before continuing.)

This printer supports many of the standard WordStar printing capabilities without requiring any changes. You can:

1. Print documents from the No-File Menu.
2. Use dot commands except for lines per inch and characters per inch.
3. Print boldface, underline, double-strike, strikeout, superscript and subscript characters as well as use print pause.

4. Select and print variable information for merge letters, etc.

#### ■ User-defined print commands

There are several CONTROL-P (^P) commands that automatically work with this printer and require no changes. They include:

^PS Underscore	^PB Boldface
^PD Double-strike	^PX Strikeout
^PT Superscript	^PV Subscript
^PC Print Pause	

It is also possible to define the ^PA (alternate pitch) command to change the print pitch of your document. The WordStar User's Manual fully describes the use of these ^P functions. You should refer to your manual if you need help with them.

There are four alternate ^P codes that can be defined during the installation of your WordStar program to perform other printer functions. They are ^PQ, ^PW, ^PE, and ^PR. The process of defining ^P commands is called "patching" and is a fairly complicated process. Once you have successfully defined these codes, they are inserted in your text exactly like other ^P commands. If you wish to use them, refer to the WordStar User's Manual for instructions or contact your dealer for assistance.

Perhaps the most useful user-defined ^P command is ^PE. If you define this as an escape (ASCII code 27), you can then access nearly all of the advanced features of this printer. Without this patch, you cannot place an escape in the WordStar document and subsequently, you are limited to using WordStar's repertoire of print functions. A shame when you have a powerful printer!

### USING THE PRINTER WITH LOTUS 1-2-3

Lotus is one of the integrated software packages that include a spreadsheet, a database manager and graphics. We will look at how to print Lotus 1-2-3 spreadsheet.

Lotus 1-2-3 uses the */Print* command to print spreadsheets. When you enter */P*, a menu appears that presents you with a number of choices. Lotus 1-2-3 gives you a lot of flexibility in printing spreadsheets through this menu, but you *have* to define the range to print. All the other items have default values that make getting started easy.

If you do change several of the things listed in the */Print* menu, Lotus 1-2-3 will remember the selections that you have made and use them each time you print the spreadsheet. They are even saved with the spreadsheet so that they will be the same the next time that you use the spreadsheet.

You can specify the range to print in all the normal ways: by pointing, by typing the cell addresses of the endpoints, by entering a range name, or by using the F3 key to point to a range name.

After you have specified a range to print, and changing any of the other options that you wish, start printing the spreadsheet by selecting the *Go* option. Lotus 1-2-3 will split the spreadsheet into sections to fit onto pages if it won't all fit on one page.

Let's look at some of the other options on the */Print* menu, and see how they add to the flexibility of printing spreadsheets.

The *Line* option advances the paper one line. Use this to put space between different sections of your spreadsheets when you print them. The *Page* option advances the paper to the top of a new page. Use this option to start on a new page.

Selecting the *Align* option tells Lotus 1-2-3 that you have moved the paper to the top of a new page. Use this option after using the Paper Feed key to move the paper or after inserting a new single sheet of paper.

The *Clear* option allows you to clear any or all of the other options that you have selected. The *Quit* option ends the */Print* command and returns you to Ready Mode.

Selecting *Options* from the */Print* menu presents you with some additional page format selections.

You can add *Headers* or *Footers* to each page of your output. A header is a line that prints at the top of each page, while a footer is a line that prints at the bottom of each page.

Lotus 1-2-3 has three characters that perform special functions when they are included in a header or a footer. You can include sequential page numbers on each page by including the # character where you want the page number to print (For example, Page #).

The current date will be printed if you include the @ character in a header or footer. (For example: As of @.)

You can direct sections of headers and footers to the left, right, or center by using the | character. Each header or footer is divided into three sections; Left, center, and right. The | character shows the limits of these sections. So to print a header



with the date to the left, a title in the center, and a page number to the right, the header might look like this:

@|Spreadsheet Title|Page #

And, on August 12, 1986, the results might look like this:

12-Aug-86      Spreadsheet Title      Page 1

Another of the selections under *Options* is *Setup*. This selection allows you to create a *setup string* that will be sent to the printer before each section of the spreadsheet is printed. You can include non-printing codes in the setup string by using a backslash (\) followed by a three digit number that consists of the decimal ASCII value for the code that you wish to send (with leading zeros if required). For example, to print a worksheet in condensed print, use the setup string \015. This sends ASCII 15 which is the code for condensed printing. The following table shows how many character columns will fit with different printing width, and the setup string to get each width.

**Table 3-2**  
**Print columns on a page with Lotus 1-2-3**

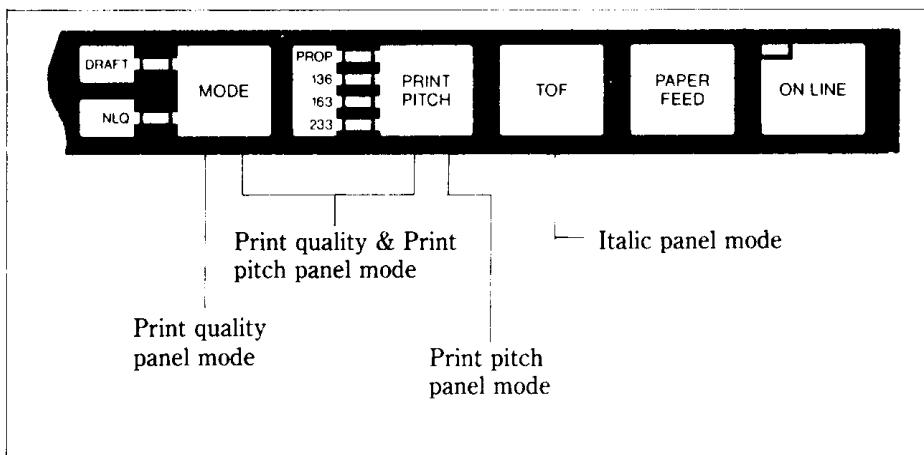
Pitch	Characters per line	Setup codes
Pica	136	\018 \027P
Elite	163	\018 \027M
Condensed Pica	233	\027P\015
Condensed Elite	272	\027M\015
Expanded on	—	\027W\001
Expanded off	—	\027W\000
NLQ on	—	\027x\001
NLQ off	—	\027x\000
Proportional on	—	\027p\001
Proportional off	—	\027p\000

## USING THE PANEL MODES

At the end of this chapter, we'll explain about the "Panel" mode, which is powerful function of the printer. Some commercial software does not support defining to define your own selections. In this case, use the "Panel" modes.

Selection of any of the Panel Modes at power-on ensures that your choices remain in effect until you turn the power off. This means that the printer will ignore any codes sent by the software that you are using. The Panel Modes allow selection of the following printing attributes:

Key	Type of Panel mode
Mode	Print quality (draft or NLQ)
Print pitch	Print pitch
TOF	Italic printing



**Figure 3-1.** The Panel Modes — hold down keys while turning power on.

If you want to set only one attribute, for example, the Print Pitch Panel Mode, press the PRINT PITCH key on the control panel when you turn on the power. After a second, you will hear a beep, and the ON LINE indicator will glow. To change the pitch to another, press the ON LINE key, select the desired pitch, and press the ON LINE key again. The Print Pitch Panel Mode is now set to the pitch of your choice.

Similarly with Draft and NLQ — turn on the power while holding the MODE key, and wait for the ON LINE indicator glow. If you want to change the character, press the ON LINE key, press the MODE key once again to make your choice, and press the ON LINE key again. Remember that you may select which print mode is the standard one by setting DIP switch 1-2.

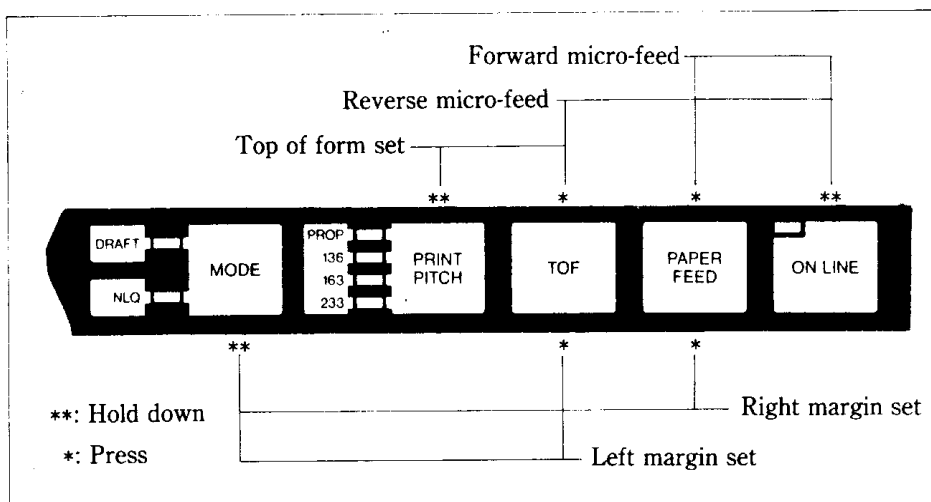
To select the Italic Panel Mode, press the TOF key while turning on the power.

More than one attribute may be set in this way. For example, if you wish to set both print pitch and print quality, press BOTH the PRINT PITCH and MODE keys when turning on the power, and after the ON LINE indicator glows, make further selections as necessary.

## ADVANCED PANEL FUNCTIONS

The printer has the capability to do some basic formatting from the control panel, as well as move the platen by precise amounts. The following formatting and platen movements may be performed from the control panel.

Key	Functions
On Line & Paper Feed	Forward micro-feed
On Line & TOF	Reverse micro-feed
Print Pitch & TOF	Top of form setting
Mode & TOF	Setting of left margin
Mode & Paper Feed	Setting of right margin



**Figure 3-2.** You can set many functions by the combinations of the control panel keys in the Off Line mode.

### ■ Setting print start position

When you want to align the print start position, you can set it by the micro-feed operation with the control panel, instead of turning the platen knob manually.

1. Set the Off Line mode by pressing the On Line key.
2. While holding down the On Line key, press one of the following keys.
  - Paper Feed key – Forward micro-feed
  - TOF key – Reverse micro-feed
3. When you can set the print start position, release the Paper Feed key or the TOF key first, then release the On Line key.

#### ■ Setting the top of form

When you turn on the printer, the top of form is automatically set to the current position. If you want to change the position, you can reset it by the following procedures.

1. Set the Off Line mode by pressing the On Line key.
2. While holding the Print Pitch key, press the TOF key. Your printer acknowledges the new top of form with the sound of beep.

#### ■ Setting the left and right margins

As you'll learn in Chapter 5, you can set the left and right margins with the control codes. In addition, you can set them manually just like a typewriter by the following procedures.

1. Set the Off Line mode by pressing the On Line key.
2. While holding the Mode key, press one of the following keys.
  - TOF key – Left margin set
  - Paper Feed key – Right margin set
3. While holding the two keys, the print head moves across the page step-by-step.
4. When the print head goes to the position where you want to set margin, release the two keys. So the printer acknowledges the margin with the sound of beep.

---

---

## CHAPTER 4

# PRINTING WITH BASIC

---

---

**Subjects covered in Chapter 4 include—**

- **Listing BASIC programs on the printer**
- **How a program prints things**
- **Control codes, escape codes, and command syntax**
- **Selecting the right software mode**
- **Near letter quality (NLQ) characters**
- **Fixed and proportional character spacing**
- **Special printing—**
  - Printing in italics**
  - Underlining**
  - Superscripts and subscripts**
  - Boldface and emphasized text**
  - Mixing print modes**

To show you how to control your printer from a program, we have chosen BASIC because it is easy to learn and easy to use. Also, more personal computer users program in BASIC than in any other language.

The rest of this manual will show you a little BASIC — just enough for you to use your printer. We're not going to try to make you an expert programmer, though, only get you started. There are many excellent books that will teach you BASIC, so if you discover that you like to program you should have no trouble learning more about it.

### **SOME BASICS OF BASIC**

#### **■ First steps**

The first things that a beginner learns to do are to list a program and to print a character string. Certainly these are the

easiest operations one can do, but even they may depend on what computer you have. In Microsoft BASIC, we can list all the steps in a program by entering LIST. This lists them on the CRT screen; if we want to print them on a printer, we prefix the command with an L (enter LLIST).

The Microsoft BASIC command for outputting information is PRINT. Like the LIST command, this displays the information on the CRT screen so we have to add an L ( $\rightarrow$  LPRINT) if we want to use the printer. Just put whatever you want to print between quotes and after LPRINT (anything enclosed in quotes is called a character string). For example, we would use LPRINT "Hello!" to output "Hello!" to the printer. We'll see later how to LPRINT more than just character strings.

We started with Microsoft BASIC because it is the most widely used version of BASIC. The programs in this manual are written in Microsoft BASIC so they should run on most computers. But if strange things happen when you try to run a program, check the BASIC manual that came with your computer.

Let's consider Apple II computers for a minute. These popular computers use their own brand of BASIC. To use an Apple II, enter the following—

```
PR#1      PR#1
LIST      PRINT "Hello!"
PR#0      PR#0
```

The PR#1 tells the Apple to send everything to the printer, the LIST or PRINT command sends it, and the PR#0 returns output to the screen.

Now that we know how to address the printer, let's try listing a BASIC program. We will load a program into memory ready to program printer operation — just as soon as we learn a little bit about the ASCII codes.

#### ■ ASCII codes and the CHR\$ function

You can talk to your computer in BASIC, but your computer and your printer talk to each other in what are known as ASCII codes. In the ASCII code, each number from 0 to 255 has a particular meaning — 36, for example, makes the printer print a dollar sign. Some numbers cause the printer to do other things, too. For instance, sending a 7 sounds the printer's bell.

Taken together, these numbers and their meanings make up the ASCII code (pronounced *ask-key*), which stands for the *American Standard Code for Information Interchange*. There are ASCII codes for all the letters of the alphabet (upper case and lower case), 0 to 9, most punctuation marks, and some (but not all) of the functions of the printer.

There are a number of different ways to represent an ASCII code, depending on how you are using it. For example, the ASCII codes for the upper-case letter "A" are 65 (decimal) or &H41 (hexadecimal). Or you can just call it "A". Appendix B shows all of the ASCII codes.

BASIC uses the CHR\$ function to represent ASCII characters and many functions. To print the letter "A" we would enter LPRINT CHR\$(65). To make the printer's bell sound, we would enter LPRINT CHR\$(7). In general, we print a character by entering LPRINT CHR\$(ASCII code) to the printer.

We can also use hex ASCII codes. Although we use only decimal ASCII codes in this manual, in some applications it will help if you understand what a hex code is. "Hex" is short for hexadecimal and refers to a base-16 number (the numbers we use in everyday life are base 10). Since the hex system needs 16 digits, it uses the numerals 0 through 9 and also the letters A through F. In BASIC programs, you can always tell that a number is in hexadecimal by the "&H" immediately preceding it. The ASCII code for the letter "A" (65 in decimal) is &H41 in hex.

#### ■ Control codes

ASCII codes with values of 32 or less do not correspond to keys on the keyboard. These codes control many of the printer's functions, so we call them control codes. To enter a control code from the keyboard, we have to press two keys at the same time — the "control" key and one other. The other key determines what code is sent — pressing the control (CTRL) key and A sends ASCII code 1, CTRL B sends ASCII code 2, and so on.

Your printer has a lot of control codes to let you do some useful things. Let's try one that we've mentioned several times already:

```
10 ' Demo of ASCII code
20 LPRINT CHR$(7)
30 END
RUN
```

That's the printer's bell (we call it that even though it sounds like a buzzer). We'll learn more about it in later — we just wanted to show you a control code that would get your attention right away!

There are four common ways of referring to a control code: the name of the code or its abbreviation, the decimal ASCII value, the hexadecimal ASCII value, and the "CTRL-" value. For example, the ASCII code that causes the printer to advance the paper one line is decimal 10. This code may be referred to by any of the following:

line feed	— the name of the code
⟨LF⟩	— its abbreviation
ASCII 10	— its decimal value
ASCII &H0A	— its hexadecimal value (the &H signifies hex)
CHR\$(10)	— the way it's used in BASIC
CTRL-J	— the way you send it from a keyboard

Of course, most of the time we don't need to bother with these. The computer is smart enough to know that when we press the "A" key we want to print the letter "A" — it takes care of all the intermediate steps.

Appendix B is a table that shows the various names for each code so you can convert back and forth. The microcomputer world is not very consistent in describing ASCII codes, so it's important that you have a basic knowledge of them.

### ■ The escape codes

Back when the ASCII system was set up, computer equipment was relatively simple and thirty-three control codes were considered sufficient at the time. The American Standards people realized that eventually more control codes would be needed, so they included the escape (ESC) code to allow almost any number of additional codes to be defined when they became necessary.

ESC allows us to "escape" from the ordinary set of control codes so we can specify additional functions and other information needed for a printer function. In this manual, we'll write the ESC code inside broken brackets, like this — ⟨ESC⟩.

⟨ESC⟩ — decimal 27 — is always followed by at least one other number; it is never used alone. The whole series of related



numbers is called an escape sequence.

#### ■ A note on command syntax

Because the readers of this manual will be running such a wide variety of applications on so many different computers, we can't show the exact way of sending codes to the printer for each one of them. Instead, as we introduce you to each new command, we will show the commands as in this example:

```
<ESC> "W" 1
```

This command turns on expanded printing. <ESC>, as we mentioned earlier, is the escape code (which is ASCII code 27). A letter or number in quotes (such as the "W" above) means that the character should be sent to the printer, but without the quotes. In our example, you should send a capital W following the escape code. In BASIC, you could do this in a couple of ways: by sending the character itself (e.g. LPRINT "W"); or by using the CHR\$ function to send the ASCII code for the character (e.g. LPRINT CHR\$(87);).

Many of printer commands end with a 1 or 0. When shown as in the above example (i.e., no quotes and no "CHR\$"), you can use either ASCII code 1 (i.e., CHR\$(1)) or the character "1" (which is ASCII code 49). The same principle applies to commands ending with 0.

So for our example above, any of these BASIC statements will have the same result:

```
LPRINT CHR$(27);"W";CHR$(1)
LPRINT CHR$(27);"W";CHR$(49)
LPRINT CHR$(27);"W1"
```

Even though there are many commands that require the use of ASCII code 0 (the <NUL> character), the number "0" (zero or ASCII code 48) cannot be substituted. In these cases, instead of an unadorned 0 we will show CHR\$(0) each time these commands are referenced.

That's it for the basics. You are now ready to learn how to use the many features of your printer.

#### ■ Selecting the right software mode

For this printer to correctly respond to control codes, you

must make sure that you've set the DIP switches properly.

The rest of this manual discuss the various control codes to control this printer. You'll find that many features have different codes for either the Standard mode or the IBM mode.

The Standard Mode emulates the Epson FX-85 printer. The IBM Mode emulates the IBM Graphics printer. You can select one of these modes by setting DIP switch 2-5. (For details, please refer to Appendix A.)

## SOME SPECIAL KINDS OF TEXT

If you looked carefully at your printer's self test, you probably noticed that it can print in italics. But that's not all! Your printer can underline characters, print superscripts and subscripts, and perhaps most exciting, print near letter quality characters.

### ■ Near Letter Quality characters

This printer's Near Letter Quality (sometimes abbreviated as NLQ) character set is ideal for correspondence and other important printing, as it produces very high quality characters. Normally, your printer prints draft quality characters. This is adequate for most work and has the fastest printing speed. For the final printout, try NLQ. The program below shows an example.

```
10 ' Demo of NLQ character set
20 LPRINT CHR$(27);"x1";
30 LPRINT "This line shows NEAR LETTER QUALITY!"
40 LPRINT CHR$(27);"x0";
50 LPRINT "This line shows standard print."
```

In this program, line 20 selects NLQ characters with  $\langle \text{ESC} \rangle$  "x" 1 command. Line 30 prints a sample before line 40 switches printer back to draft printing with an  $\langle \text{ESC} \rangle$  "x" 0. When you run the program you should get this:

```
This line shows NEAR LETTER QUALITY!
This line shows standard print.
```

Now turn off the power switch. After you turn on the power

switch while holding the Mode key down on the control panel, set the NLQ mode with the Mode key while in the Off Line mode. Then run the program again. You should get like this:

This line shows NEAR LETTER QUALITY!  
This line shows standard print.

As you can see, now the printout only contains NLQ characters. This is because we set the printer to the "Print Quality Panel" mode at power on, so the printer ignored the control codes to set or cancel NLQ characters. This is a very useful way to print NLQ characters if you are using a packaged software which does not support the NLQ character mode.

**Table 4-1**  
**Near letter quality commands**

Function	Control code
Near letter quality ON	<ESC> "x" 1
Near letter quality OFF	<ESC> "x" 0

#### ■ Italic printing

*Italic* letters are letters that are slanted to the right. Your printer can print all of its letters in *italic* as well as the roman (standard) letters you are accustomed to. Italics can be used to give extra emphasis to certain words. The commands to turn italic on and off are shown in Table 4-2.

**Table 4-2**  
**Italic commands**

Function	Control code
Italic ON	<ESC> "4"
Italic OFF	<ESC> "5"

Use this program to see italic characters:

```
10 ' Demo of italic and roman
20 LPRINT CHR$(27);"4";
30 LPRINT "This line is in ITALIC characters."
40 LPRINT CHR$(27);"5";
50 LPRINT "This line is in ROMAN characters."
```

Here is what you should get:

```
This line is in ITALIC characters.
This line is in ROMAN characters.
```

In this program, line 20 turns italic on with `<ESC> "4"`, and line 40 turns italic off with `<ESC> "5"`.

Now, set the "Italic Panel" mode, as described in Chapter 3, then run the program again. You should get like this:

```
This line is in ITALIC characters.
This line is in ROMAN characters.
```

As you can see, this time the printer ignored the control codes to set or cancel italic characters.

### ■ Underlining

Not only can your printer print all styles of printing in both roman and italic, but it can underline them too. The control codes are shown in Table 4-3.

**Table 4-3**  
**Underline commands**

Function	Control code
Underline ON	<code>&lt;ESC&gt; "- 1</code>
Underline OFF	<code>&lt;ESC&gt; "- 0</code>

It's that simple. Let's try it with this program:

```
10 ' Demo of underlining
20 LPRINT CHR$(27);"-1";
30 LPRINT "This phrase is UNDERLINED;";
40 LPRINT CHR$(27);"-0";
50 LPRINT " this is not."
```

It should come out like this:

```
This phrase is UNDERLINED; this is not.
```

In this program underline is turned on in line 20 with `<ESC> “-” 1`, and then off in line 40 with `<ESC> “-” 0`. There’s a new aspect to this program, though. The semicolons at the end of the first three lines told BASIC that those lines were to be continued. Therefore, BASIC didn’t send a carriage return and line feed at the end of those lines. We just did this to illustrate that all these control codes can be used in the middle of a line. It’s easy to underline or *italicize* only part of a line.

#### ■ Superscripts and subscripts

Your printer can print in two different heights of characters. The smaller characters are called *superscripts* and *subscripts* and are half the height of normal characters. *Superscripts* print evenly with the tops of regular printing while *subscripts* print evenly with the bottom of regular printing. They are frequently used to reference footnotes, and in mathematical formulas.

Table 4-4 has the codes for using superscripts and subscripts.

**Table 4-4**  
**Superscripts and subscripts commands**

Function	Control code
Superscript ON	<code>&lt;ESC&gt; “S” 0</code>
Subscript ON	<code>&lt;ESC&gt; “S” 1</code>
Super and subscript OFF	<code>&lt;ESC&gt; “T”</code>

Try this program to see them work:

```

10 ' Demo of superscripts and subscripts
20 LPRINT "Look! ";
30 LPRINT CHR$(27);"S0";
40 LPRINT "SUPERSCRIPTS ";
50 LPRINT CHR$(27);"T";
60 LPRINT "& ";
70 LPRINT CHR$(27);"S1";
80 LPRINT "SUBSCRIPTS ";
90 LPRINT CHR$(27);"T";
100 LPRINT "on one line."

```

Look! SUPERSCRIPTS & SUBSCRIPTS ON one line.

Here line 30 turns on superscripts with `<ESC> "S" 0`. It's turned off in line 50 with `<ESC> "T"`. Then between printing text, subscripts are turned on in line 70 with `<ESC> "S" 1`, and finally off in line 90. Again, everything prints on one line because of the semicolons.

## CHANGING THE PRINT PITCH

In "printer talk," the number of characters that can be printed in one inch is called the print pitch or character pitch. Normally, your printer is set for 10 characters per inch, which is called *pica* (and is the same as the pica pitch on most typewriters). This works out to 136 characters per line.

You can also print 12 character per inch (*elite pitch*). This gives you 163 characters per line.

You can set these pitches by using the Mode key on the control panel manually, or by software as shown in the table below.

**Table 4-5**  
**Print pitch commands**

Pitch	Characters/inch	Control code
Pica	10	<code>&lt;ESC&gt; "P"</code>
Elite	12	<code>&lt;ESC&gt; "M"</code>

Try this program to see how these two pitches work. Be sure to set the printer to draft mode.

```
10 ' Demo of pica and elite pitches
20 LPRINT CHR$(27);"M";
30 LPRINT "This line is ELITE pitch."
40 LPRINT CHR$(27);"P";
50 LPRINT "This line is PICA pitch (normal)."
```

When you run this program you should get this:

```
This line is ELITE pitch.
This line is PICA pitch (normal).
```

Line 20 turns on elite pitch with `<ESC> "M"`. Line 30 prints

the line at 12 characters per inch. The  $\langle$ ESC $\rangle$  "P" in line 40 resets the printer to pica pitch and line 50 prints the line in pica pitch.

#### ■ Expanded print

Each of the print pitches can be enlarged to twice its normal width. This is called expanded print. Try this program to see how it works:

```
10 ' Demo of expanded print
20 LPRINT "Demonstration of ";
30 LPRINT CHR$(14);
40 LPRINT "EXPANDED";
50 LPRINT CHR$(20);
60 LPRINT " printing."
70 LPRINT "Notice that ";
80 LPRINT CHR$(14);
90 LPRINT "EXPANDED mode"
100 LPRINT "automatically turns off at the end of a
    line."
```

```
Demonstration of EXPANDED printing.
Notice that EXPANDED mode
automatically turns off at the end of a line.
```

Expanded print set with CHR\$(14) is automatically cancelled at the end of the line. This is convenient in many applications, such as for one line titles. Note that you didn't need to put an  $\langle$ ESC $\rangle$  in front of the CHR\$(14), although  $\langle$ ESC $\rangle$  CHR\$(14) works just the same.

You can also cancel one line expanded print *before* a carriage return with CHR\$(20), as done in line 50.

Sometimes you may wish to stay in expanded print for more than one line. Change your program to this:

```
10 ' Demo of permanent expanded mode
20 LPRINT CHR$(27);"W1";
30 LPRINT "Permanent expanded"
40 LPRINT "mode stays on until"
50 LPRINT "is is ";
60 LPRINT CHR$(27);"W0";
70 LPRINT "turned off."
```

Now the results look like this:

```
Permanent expanded
mode stays on until
it is turned off.
```

When you turn on expanded print with `<ESC> "W" 1` it stays on until you turn it off with `<ESC> "W" 0`.

**Table 4-6**  
**Expanded print commands**

Function	Control code
One line expanded ON	<code>CHR\$(14) or &lt;ESC&gt;CHR\$(14)</code>
One line expanded OFF	<code>CHR\$(20)</code>
Expanded ON	<code>&lt;ESC&gt; "W" 1</code>
Expanded OFF	<code>&lt;ESC&gt; "W" 0</code>

#### ■ Condensed print

Each of the print pitches also can be condensed to its normal width. This is called condensed print. Try this program to see how it works:

```
10 ' Demo of condensed print
20 LPRINT "Demonstration of ";
30 LPRINT CHR$(15);
40 LPRINT "CONDENSED";
50 LPRINT CHR$(18);
60 LPRINT " printing."
```

```
Demonstration of CONDENSED printing.
```

Condensed print set with `CHR$(15)` stays on until you turn it off with `CHR$(18)`. Note that you don't need to put an `<ESC>` in front of the `CHR$(15)`, although `<ESC> CHR$(15)` works just the same.



**Table 4-7**  
**Condensed print commands**

Function	Control code
Condensed ON	CHR\$(15) or <ESC> CHR\$(15)
Condensed OFF	CHR\$(18)

By combining expanded print and condensed print with the two pitches, this printer has eight different character widths available.

Enter this program to see how the print pitches, expanded print and condensed print can be combined:

```

10 ' Demo of various print pitches
20 LPRINT CHR$(15);
30 LPRINT CHR$(27);"M";
40 LPRINT "This line is CONDENSED ELITE pitch."
50 LPRINT CHR$(27);"P";
60 LPRINT "This line is CONDENSED PICA pitch."
70 LPRINT CHR$(18);
80 LPRINT CHR$(27);"M";
90 LPRINT "This line is NORMAL ELITE pitch."
100 LPRINT CHR$(27);"P";
110 LPRINT "This line is NORMAL PICA pitch."
120 LPRINT CHR$(27);"W1";
130 LPRINT CHR$(15);
140 LPRINT CHR$(27);"M";
150 LPRINT "This line is EXPANDED CONDENSED ELITE."
160 LPRINT CHR$(27);"P";
170 LPRINT "This line is EXPANDED CONDENSED PICA."
180 LPRINT CHR$(18);
190 LPRINT CHR$(27);"M";
200 LPRINT "This is EXPANDED ELITE."
210 LPRINT CHR$(27);"P";
220 LPRINT "This is EXPANDED PICA."
230 LPRINT CHR$(27);"W0"
240 END

```

Here's what you should get from this program:

This line is CONDENSED ELITE pitch.  
 This line is CONDENSED PICA pitch.  
 This line is NORMAL ELITE pitch.  
 This line is NORMAL PICA pitch.  
 This line is EXPANDED CONDENSED ELITE.  
 This line is EXPANDED CONDENSED PICA.  
 This is EXPANDED ELITE.  
 This is EXPANDED PICA.

### ■ Proportional printing

Have you ever looked closely at the printing in books and magazines? Doesn't it look nice? The main reason is that each character is given an amount of space proportional to its actual width. A typewriter (and most printers), on the other hand, give every character the same amount of space, no matter how wide it is. (Pica pitch, for example, gives a "w" and an "i" 1/10 of an inch each. Looking at these letters you see that a "w" is two or three times as wide as an "i".)

Well, you too can enjoy professional-looking proportional printing. You can turn proportional printing on and off with the following commands.

**Table 4-8**  
**Proportional commands**

Function	Control code
Proportional ON	<ESC> "p" 1
Proportional OFF	<ESC> "p" 0

Try this program to see how the proportional spacing works.

```

10 ' Demc of proportional printing
20 LPRINT CHR$(27);"M";
30 LPRINT "This line is NORMAL ELITE printing."
40 LPRINT CHR$(27);"p1";
50 LPRINT "This line is PROPORTIONAL ELITE."
60 LPRINT CHR$(27);"P";
70 LPRINT "This line is PROPORTIONAL PICA."
80 LPRINT CHR$(27);"p0";
90 LPRINT "This line is NORMAL PICA printing."
100 END
  
```

When you run this program you should get this:

```
This line is NORMAL ELITE printing.
This line is PROPORTIONAL ELITE.
This line is PROPORTIONAL PICA.
This line is NORMAL PICA printing.
```

Line 20 selects the elite pitch and line 40 turns on the proportional printing with `<ESC> "p" 1`. Line 50 prints a line with proportional elite pitch. Then, line 60 selects the pica pitch, so that line 70 prints a line with proportional pica pitch. Finally, line 80 resets the proportional printing and line 90 prints a line in normal pica pitch.

**NOTE:** When you set the "Print Pitch Panel" mode by the Print Pitch key on the control panel at power-on, these control codes related print pitches except expand print mode is ignored.

## MAKING WORDS STAND OUT

Your printer has good print density when it's just printing normally. But sometimes you may want something to stand out from the rest of the page. This printer provides two ways to do this: boldface and emphasized print. Both of these go over the characters twice, but they use slightly different methods to darken the characters. Let's try them and see what the difference is.

The following table shows the control codes for getting into and out of boldface and emphasized modes.

**Table 4-9**  
**Print emphasis commands**

Function	Control code
Boldface ON	<code>&lt;ESC&gt; "G"</code>
Boldface OFF	<code>&lt;ESC&gt; "H"</code>
Emphasized ON	<code>&lt;ESC&gt; "E"</code>
Emphasized OFF	<code>&lt;ESC&gt; "F"</code>

Try them now with this little program:

```
10 ' Demo of boldface and emphasized
20 LPRINT CHR$(27);"G";
30 LPRINT "This line is BOLDFACE printing."
40 LPRINT CHR$(27);"E";
50 LPRINT "This line is BOLDFACE and EMPHASIZED."
60 LPRINT CHR$(27);"H";
70 LPRINT "This line is EMPHASIZED printing."
80 LPRINT CHR$(27);"F";
90 LPRINT "This line is normal printing."
100 END
```

Run this program. The results will look like this:

```
This line is BOLDFACE printing.
This line is BOLDFACE and EMPHASIZED.
This line is EMPHASIZED printing.
This line is normal printing.
```

Line 20 turns on boldface with  $\langle \text{ESC} \rangle$  "G" and line 30 prints a line of text. In line 40 emphasized is turned on with  $\langle \text{ESC} \rangle$  "E". Line 50 prints a line of text in boldface *and* emphasized. Line 60 then turns boldface off with  $\langle \text{ESC} \rangle$  "H" so that line 70 can print in emphasized only. Finally, line 80 turns emphasized off, so your printer is set for normal printing.

Look closely at the different lines of printing. In the line of boldface printing each character has been printed twice, and the paper was moved up slightly the second time they were printed. In emphasized printing, the characters are moved slightly to the right the second time the printer prints. The second line combined both of these so that each character was printed 4 times.

## MIXING PRINT MODES

We have learned how to use the various print modes individually and together. Now we'll see how to combine them more efficiently.

You have at your disposal a unique command that lets you choose any valid combination of print modes and pitch. This is the Master Print mode command. It looks like this:

```
 $\langle \text{ESC} \rangle$  "!" n
```

Here, the value of  $n$  defines the print style to be selected. The value of  $n$  can range from 0 to 255, which is the range of values that can be stored in one eight-bit byte. If you look at each bit in this byte, you'll find that each one represents a printing style variation. Adding the binary values of the selected bits gives the value of  $n$  for a particular combination of print styles.

Table 4-10 shows the decimal values of the bits in the Master Print byte. To calculate the value  $n$  for a particular combination of printing styles, just add the decimal values of the features that you want to combine.

**Table 4-10**  
**Values of mixing print styles for Master Print**

Bit	Print style	Decimal value
1	Elite print	1
2	Proportional print	2
3	Condensed print	4
4	Emphasized print	8
5	Boldface print	16
6	Expanded print	32
7	Italics	64
8	Underline	128

For example, if you want to select elite expanded boldface print, you would calculate the value of  $n$  like this:

Elite	1
Boldface	16
Expanded	32
$n =$	<u>49</u>

The command would look like this:

```
CHR$(27);"!";CHR$(49)
```

To better understand the way the print modes work, consider that each mode except pica (pica is the default) has a separate switch that can be turned on and off via software. Once the switch is on, it stays on until turned off. However, when two modes that conflict are turned on at the same time, the printer must choose which one to use.

For example, suppose you turn on both Elite and Emphasized modes. These cannot combine, so the printer must make a choice; in this case, the printer chooses Elite.

*Summary notes*

- 1) Pica is the default pitch and is active when Elite is turned off.
- 2) When two modes conflict, the one of lesser priority bit-wise is cancelled. For example, Condensed and Emphasized can not be printed at the same time, printing is Emphasized.
- 3) Elite cancels Emphasized.
- 4) Underline, Expanded and Italics modes combine with any print modes.
- 5) Emphasized will not mix with Elite or Condensed.

---

---

## CHAPTER 5

# FORMATTING TEXT

---

---

**Subjects covered in Chapter 5 include—**

- **The carriage return and line feed**
- **The amount of space between lines**
- **Moving to the next page**
- **The number of lines on a printed page**
- **Horizontal and vertical tabs**
- **Setting margins – left, right, top and bottom**
- **Centering and aligning**

Chapter 4 showed us the basic techniques for using the printer. Now we're ready for the more advanced ones. We'll concentrate on changing the appearance of the page to suit our needs.

### **LINES AND LINE SPACING**

#### ■ Starting a new line

Up until now the only time we have thought about printing on a new line is when we *didn't* want it to happen. We learned that putting a semicolon (;) at the end of a BASIC line will *not* end the line of printing. So somehow, the computer tells the printer when to end one line and start another.

There are two codes that are used to end one line and start another. They are *carriage return* (CHR\$(13)) and *line feed* (CHR\$(10)). Like the escape codes, they have been given abbreviations which you'll find many texts (including this one): <CR> and <LF>. The codes are simple, but their action is a little confusing (especially with BASIC). Let's begin with the carriage return. Each time the printer receives a CHR\$(13) it returns the print head to the left margin. It does not advance the paper (if DIP switch 1-8 is on; see below).

Line feed is more complicated. Each time the printer receives a CHR\$(10) it both advances the paper one line and returns the print head to the left margin, ready to start a new line.

Now to add a little confusion — most (but not all) versions of BASIC add a line feed (CHR\$(10)) to every carriage return (CHR\$(13)) they receive. If your version of BASIC doesn't do this, then you should turn DIP switch 1-8 off so that your printer will add the line feed for you. When you have DIP switch 1-8 off the printer will do the same thing when it receives a carriage return as it does when it receives a line feed.

If you find that your printer double spaces when it should single space, then you probably need to turn DIP switch 1-8 on.

### ■ Reverse line feeds

Your printer can move the paper up or down. The unique tractor design allows the paper to be fed in either direction without jamming. This allows you to move around the page at will. You can use this feature to print several columns of text side by side, or to print a graph and then move back up and insert descriptive legends. As you experiment you're bound to come up with more uses!

The simplest form of reverse paper feeding is a reverse line feed. The code is <ESC> <LF>, which causes the paper to move down (in effect, moving the printing *up*) one line. A "line" used in a reverse line feed is the same size as a line in a regular line feed (this is normally 1/6 inch). When you change the line spacing (which you'll read about next), both forward and reverse line feeds change.

**Table 5-1**  
**Line feed commands**

Function	Control code
Return print head to left margin	CHR\$(13)
Advance paper one line	CHR\$(10)
Reverse paper one line	<ESC> CHR\$(10)

### ■ Changing the line spacing

When you turn your printer on, the line spacing is set to 6 lines per inch. This is fine for most printing applications, but when you want something different, the printer makes it easy to set the line spacing to whatever you want.

Try this program to see how easy it is to change the line spacing:



```

NEW
10 ' Demo of line spacing
20 FOR I=1 TO 25
30 IF I=13 THEN 60
40 LPRINT CHR$(27);"A";CHR$(I);
50 LPRINT "THIS LINE SPACING IS SET TO";I
60 NEXT I
70 LPRINT "LINE SPACING IS SET TO 1/6 INCH
(NORMAL). "
80 LPRINT CHR$(27);"2"
90 END

```

This is what you will get:

```

THIS LINE SPACING IS SET TO 1
THIS LINE SPACING IS SET TO 2
THIS LINE SPACING IS SET TO 3
THIS LINE SPACING IS SET TO 4
THIS LINE SPACING IS SET TO 5
THIS LINE SPACING IS SET TO 6
THIS LINE SPACING IS SET TO 7
THIS LINE SPACING IS SET TO 8
THIS LINE SPACING IS SET TO 9
THIS LINE SPACING IS SET TO 10
THIS LINE SPACING IS SET TO 11
THIS LINE SPACING IS SET TO 12
THIS LINE SPACING IS SET TO 14
THIS LINE SPACING IS SET TO 15
THIS LINE SPACING IS SET TO 16
THIS LINE SPACING IS SET TO 17
THIS LINE SPACING IS SET TO 18
THIS LINE SPACING IS SET TO 19
THIS LINE SPACING IS SET TO 20
THIS LINE SPACING IS SET TO 21
THIS LINE SPACING IS SET TO 22
THIS LINE SPACING IS SET TO 23
THIS LINE SPACING IS SET TO 24
THIS LINE SPACING IS SET TO 25
LINE SPACING IS SET TO 1/6 INCH (NORMAL).

```

Line 40 changes the line spacing. The command  $\langle \text{ESC} \rangle$  "A"  $\text{CHR}\$(n)$  changes the line spacing to  $n/72$  of an inch. The loop that is started in line 20 increases the value of  $n$  (the variable I in this program) each time it is executed. So the line spacing increases as the program continues. Line 30 just shortcuts the loop when  $I = 13$ , since BASIC won't let us send  $\text{CHR}\$(13)$  without adding an unwanted  $\text{CHR}\$(10)$  to it. Finally, the  $\langle \text{ESC} \rangle$  "2" in line 80 resets the line spacing to 6 lines per inch. This is a shortcut that is the same as  $\langle \text{ESC} \rangle$  "A"  $\text{CHR}\$(12)$ .

If you run this program with DIP switch 2-5 off (IBM mode), you cannot get the printout as shown above.

The  $\langle \text{ESC} \rangle$  "A"  $\text{CHR}\$(n)$  command in the IBM mode only defines the line spacing as  $n/72$  of an inch; the  $\langle \text{ESC} \rangle$  "2" command changes the line spacing to the amount defined by the previous  $\langle \text{ESC} \rangle$  "A".

For the IBM mode, you need to change the following lines in the previous program as shown below:

```
40 LPRINT CHR$(27);"A";CHR$(I);CHR$(27);"2";  
80 LPRINT CHR$(27);"A";CHR$(12);CHR$(27);"2"
```

You may wonder why  $1/72$  of an inch was chosen as the increment for the line spacing command. There's a good reason: the dots that the printer makes are  $1/72$  inch apart. So this means that you can vary the line spacing in increments as fine as one dot — unless you want finer spacing, in which case you may use one third dot spacing.

The  $\langle \text{ESC} \rangle$  "3"  $\text{CHR}\$(n)$  command sets the line spacing in increments of  $1/216$  inch. Change line 40 in your program to this:

```
40 LPRINT CHR$(27);"3";CHR$(I);
```

and run the program again. Now the results will look like this:



```

30 LPRINT "LINE NUMBER 2.";
40 ' One-time line feed
50 LPRINT CHR$(27);"J";CHR$(100);
60 LPRINT "LINE NUMBER 3."
70 LPRINT "LINE NUMBER 4."
80 END

```

Here is what your printer will produce:

```

LINE NUMBER 1.
LINE NUMBER 2.

                LINE NUMBER 3.
LINE NUMBER 4.

```

The `<ESC> "J" CHR$(100)` in line 50 changes the spacing to 100/216 inches for one line only without moving the printhead. The rest of the lines printed with the normal line spacing. Notice that both line 30 and line 50 end with semicolons. This prevents the normal line feed from occurring.

The `<ESC> "j" CHR$(n)` command works the same way except that the paper moves in the opposite direction. Try this simple change to your program to see the difference.

```

40 ' One-time reverse line feed
50 LPRINT CHR$(27);"j";CHR$(100);

                LINE NUMBER 3.
LINE NUMBER 4.
LINE NUMBER 1.
LINE NUMBER 2.

```

## PAGE CONTROL

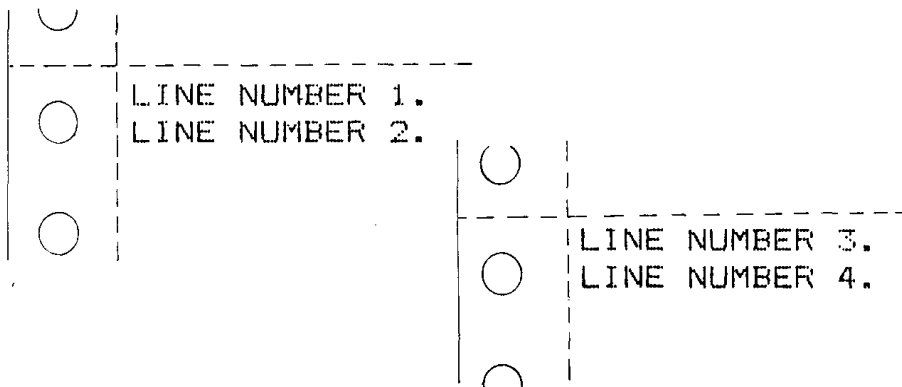
Now that we have seen how to control line spacing, we can go on to page control — positioning the printing on the page and adjusting the paper length.

### ■ Form feed

The simplest forms control code is the *form feed*. Form feed (or `<FF>`) is `CHR$(12)` and causes the printer to move the paper to the top of the next sheet. Try it by changing lines 40 and 50 to this:

```
40 ' form feed
50 LPRINT CHR$(12);
```

Before you run the program, turn your printer off and adjust the paper so that the top of the sheet is even with the top of the ribbon guide on the print head, then turn the printer back on. If you don't remember how to do this, review Chapter 2. When you run the program, the results will look like this:



The form feed (`CHR$(12)`) in line 50 caused the printer to move to the top of a new page before printing the last two lines.

### ■ Reverse form feed

Just as your printer can perform a reverse line feed, it can do a reverse form feed. This code moves the paper so that the print-head is positioned at the top of the current page. This can be used, for example, to print text in a multi-column magazine format; print the first column, then reverse form feed back to the top of the page to start the second column. The code for reverse form feed is easy to remember: `<ESC> <FF>`.

**Table 5-3**  
**Form feed commands**

Function	Control code
Advance paper to top of next page	CHR\$(12)
Reverse paper to top of current page	<ESC> CHR\$(12)

■ Changing the page length

You may have some computer forms that are not 11 inches high. That's no problem, because you can tell your printer how high the forms are that you are using. There are two commands for doing this, shown in this table.

**Table 5-4**  
**Form length control**

Function	Control code
Set the page length to <i>n</i> lines	<ESC> "C" CHR\$( <i>n</i> )
Set the page length to <i>n</i> inches	<ESC> "C" CHR\$(0) CHR\$( <i>n</i> )

Let's set up a 7 inch high form length, which is typical of many computer checks. The following program will do it.

```
NEW
10 ' Demo of variable form lengths
20 LPRINT CHR$(27);"C";CHR$(0);CHR$(7);
30 LPRINT "PAY TO THE ORDER OF:"
40 LPRINT CHR$(12);
50 LPRINT "PAY TO THE ORDER OF:"
60 END
```

This program should print "PAY TO THE ORDER OF:" twice, and they should be 7 inches apart. Line 20 sets the form length to 7 inches. After line 30 prints, line 40 sends a form feed advance the paper to the top of the next form. Line 50 then prints its message.

After you have run this program, turn off the printer and adjust the top of form position. When you turn the printer back on the page length will reset to its normal setting (usually 11 inches).

## TOP AND BOTTOM MARGINS

Some programs don't keep track of where they are printing on the page. This causes problems when you get to the bottom of a page because these programs just keep on printing, right over the perforation. This makes it very hard to read, especially if a line happens to fall right on the perforation.

The printer has a solution to this predicament. This printer can keep track of the position on the page, and advance the paper so that you won't print too near the perforation. There are two commands to do this. One controls the space at the top of the page (top margin) and the other controls the space at the bottom of the page (bottom margin). The control codes are given in the following table:

**Table 5-5**  
**Top and bottom margin commands**

Function	Control code
Set top margin to $n$ lines	$\langle \text{ESC} \rangle$ "r" CHR\$( $n$ )
Set bottom margin to $n$ lines	$\langle \text{ESC} \rangle$ "N" CHR\$( $n$ )
Cancel top and bottom margins	$\langle \text{ESC} \rangle$ "O"

In both cases the value of  $n$  tells your printer how many lines to skip, although there is a slight difference in the usage. When you set the top margin with  $\langle \text{ESC} \rangle$  "r" CHR\$( $n$ ), the value of  $n$  tells the printer what line to start printing on. When you set the bottom margin with  $\langle \text{ESC} \rangle$  "N" CHR\$( $n$ ), the value of  $n$  tells the printer how many blank lines should be left at the bottom of the page.

Let's try a simple application to see how these margins work. Enter this program, which will print 150 lines *without* top and bottom margins.

```

10 'Demo of top and bottom margins
60 LPRINT CHR$(12);  :' form feed
70 FOR I=1 TO 150
80 LPRINT "THIS IS LINE";I
90 NEXT I
110 LPRINT CHR$(12)  :' form feed
120 END

```

When you run this program it will print 150 lines right down the page and across the perforations. When it's done line 110 sends a form feed to advance to the top of the next page.

Now add the following lines to your program. (Don't forget the semicolons or you won't get quite the same results that we did.)

```
20 ' Leave 6 blank lines at the bottom of page
30 LPRINT CHR$(27);"N";CHR$(6);
40 ' Start top of page at line 6
50 LPRINT CHR$(27);"r";CHR$(6);
100 LPRINT CHR$(27);"O"; ' clear top and bottom
    margins
```

Now when you run the program, your printer skip the first six lines and the last six lines on each page. Always send a form feed after setting the top margin, or it will not work on the first page printed. That's because the top margin only takes effect after a form feed.

Line 50 sets the top margin, line 30 sets the bottom margin, and line 100 clears both margins when we are done.



○  
○  
○  
○ THIS IS LINE 1  
○ THIS IS LINE 2  
○ THIS IS LINE 3  
○ THIS IS LINE 4  
○ THIS IS LINE 5  
○ THIS IS LINE 6  
○ THIS IS LINE 7  
○ THIS IS LINE 8  
○ THIS IS LINE 9  
○ THIS IS LINE 10

○ THIS IS LINE 47  
○ THIS IS LINE 50  
○ THIS IS LINE 51  
○ THIS IS LINE 52  
○ THIS IS LINE 53  
○ THIS IS LINE 54  
○ THIS IS LINE 55

○  
○  
○ THIS IS LINE 56  
○ THIS IS LINE 57  
○ THIS IS LINE 58  
○ THIS IS LINE 59  
○ THIS IS LINE 60  
○ THIS IS LINE 61  
○ THIS IS LINE 62  
○ THIS IS LINE 63  
○ THIS IS LINE 64

○ THIS IS LINE 103  
○ THIS IS LINE 104  
○ THIS IS LINE 105  
○ THIS IS LINE 106  
○ THIS IS LINE 107  
○ THIS IS LINE 108  
○ THIS IS LINE 109  
○ THIS IS LINE 110

○  
○  
○ THIS IS LINE 111  
○ THIS IS LINE 112  
○ THIS IS LINE 113  
○ THIS IS LINE 114  
○ THIS IS LINE 115  
○ THIS IS LINE 116  
○ THIS IS LINE 117  
○ THIS IS LINE 118  
○ THIS IS LINE 119  
○ THIS IS LINE 120  
○ THIS IS LINE 121



When you want to reset the margins to the default values, you have two choices. You can either turn the printer off and back on, or you can set margin values equal to the default values. This means that you should set a left margin of 0 and right margin of 136 in pica pitch.

If you change the pitch of your printing after you set your margins, the margins will not change. They stay at the same place on the page. So if you set the margins to give you 65 columns of printing when you are using pica type, and you change to elite type, you will have room for more than 65 columns of elite printing between the margins.

## HORIZONTAL AND VERTICAL TABS

Suppose you need to move across the page to a certain position several times in a document. It's not much fun to type in space after space. You don't have to — you can "tab" your way across the page.

Your printer's tabs are like those on a typewriter, but much more powerful. You have both horizontal and vertical tabs which can be used for both text and graphics — and they're really handy for indenting paragraphs and making tables.

### ■ Horizontal tabs

Horizontal tabs are set automatically every eight positions. To move the print head to the next tab position, send CHR\$(9).

Try this program to see how the default tabs work.

```
10 ' Demo of horizontal tabbing
20 LPRINT "ONE";CHR$(9);"TWO";CHR$(9);"THREE";
   CHR$(9);"FOUR"
```

Here's what you should get—

```
ONE      TWO      THREE     FOUR
```

Even though the words are different length, they are spaced out evenly by the horizontal tabs.

Now add the following line to your program to set different horizontal tabs:

```
15 LPRINT CHR$(27);"D";CHR$(7);CHR$(14);CHR$(21);
    CHR$(0)
```

⟨ESC⟩ “D” is the command to begin setting horizontal tabs. It must be followed by characters representing the positions where you want the tabs set. In our program we are setting tabs in columns 7, 14, and 21. The final CHR\$(0) ends the string of tabs. In fact, any character that is not greater than the previous one will stop setting tabs. This means that you must put all your tab values in order, from least to greatest, or they won’t all get set.

When you run the program now it produces this:

```
ONE . TWO THREE FOUR
```

The words are now closer together, but still evenly spaced. To reset the default tabs, use the following program:

```
LPRINT CHR$(27);"e0";CHR$(8)
```

This command sets the horizontal tabs to every eight columns.

**Table 5-7**  
**Horizontal tab commands**

Function	Control code
Advance to next tab position	CHR\$(9)
Set tabs at $n1$ , $n2$ , etc.	⟨ESC⟩ “D” CHR\$( $n1$ ) CHR\$( $n2$ ) ..... CHR\$(0)
Set tabs every $n$ columns	⟨ESC⟩ “e” 0 CHR\$( $n$ )

#### ■ One-time horizontal tabs

Suppose you need to move to a position across the page, but you only need to do it once. It doesn’t make much sense to set up a tab to use only one time. There is an easier way.

The solution is called a *one-time* tab. Table 5-8 show the three commands.

**Table 5-8**  
**One-time horizontal tabs**

Function	Control code
One-time horizontal tab of $n$ spaces	$\langle \text{ESC} \rangle$ "f" 0 CHR\$( $n$ )
Absolute horizontal tab	$\langle \text{ESC} \rangle$ "\$" CHR\$( $n1$ ) CHR\$( $n2$ )
Relative horizontal tab	$\langle \text{ESC} \rangle$ "\ " CHR\$( $n1$ ) CHR\$( $n2$ )

The first command in Table 5-8 moves the print head  $n$  columns to the right. It has the same effect as sending  $n$  spaces to the printer.

The absolute horizontal tab command moves the print head to a specified position on the page. The position that you want the print head to move to (measured from the left margin) is specified by the values of  $n1$  and  $n2$  using the formula  $n1 + n2 \times 256$ . The units by which the print head actually moves vary with the print pitch you are using, as shown in Table 5-9.

Try this program to see how this works.

```
10 ' Demo of absolute horizontal tabs
20 FOR I=60 TO 70 STEP 2
30 LPRINT I;"+++++";
40 LPRINT CHR$(27);"$";CHR$(I);CHR$(0);
50 LPRINT "Horizontal tab."
60 NEXT I
70 END
```

In this program, the print head is positioned before the "H" in "Horizontal" is printed.

```
60 +++++ Horizontal tab.
62 +++++ Horizontal tab.
64 +++++ Horizontal tab.
66 +++++ Horizontal tab.
68 +++++ Horizontal tab.
70 +++++ Horizontal tab.
```

The relative horizontal tab command can move the print head right from the current position. The formula for calculating how much the print head moves is the same as in the absolute horizontal tab command. However, the units by which the print head actually moves vary with the print pitch you are using as shown in Table 5-9.

**Table 5-9**  
**Units of motion for the absolute and relative**  
**horizontal tab commands**

Print pitch	Unit of motion	
	Absolute tab command	Relative tab command
Pica pitch	1/60 inch	1/120 inch
Elite pitch	1/72 inch	1/144 inch
Condensed pica pitch	1/102 inch	1/204 inch
Condensed elite pitch	1/120 inch	1/240 inch

Try this program to see how this works.

```

10 ' Demo of relative horizontal tabs
20 FOR I=1 TO 3
30 LPRINT "Relative";
40 LPRINT CHR$(27);"\";CHR$(I*20);CHR$(0);
50 LPRINT "Horizontal";
60 LPRINT CHR$(27);"\";CHR$(I*10);CHR$(0);
70 LPRINT "Tab."
80 NEXT I
90 END

```

```

Relative Horizontal Tab.
Relative Horizontal Tab.
Relative Horizontal Tab.

```

### ■ Vertical tabs

Vertical tabs have the same kinds of uses that horizontal tabs do — they just work in the other direction. Horizontal tabs allow you to reach a specific column on the page no matter where you start from. Vertical tabs are the same. If you have a vertical tab set at line 20, a *vertical tab* (or <VT>) will move you to line 20 whether you start from line 5 or line 19.

Vertical tabs are *not* set at the power-on default. If you send a CHR\$(11) which is the ASCII code for <VT> before we have set up tabs, the command advances the paper only one line. Enter this program to see how this works.

```

10 ' Demo of vertical tabs
40 LPRINT CHR$(11);"FIRST TAB."

```

```
50 LPRINT CHR$(11);"SECOND TAB."  
60 LPRINT CHR$(11);"THIRD TAB."  
70 LPRINT CHR$(11);"FOURTH TAB."
```

Now, let's set some vertical tabs of our own. Add these lines to the program:

```
20 LPRINT CHR$(27);"B";CHR$(10);CHR$(15);  
30 LPRINT CHR$(25);CHR$(30);CHR$(0);
```

<ESC> "B" is the command to set vertical tabs. Like the horizontal tab setting command, tab positions must be defined in ascending order. Our example sets vertical tabs at lines 10, 15, 25 and 30. Then the CHR\$(11) in each of the following lines advances the paper to the next vertical tab. The printout is shown below.

FIRST TAB.

SECOND TAB.

THIRD TAB.

FOURTH TAB.

Add one more line to the program to demonstrate one more feature of vertical tabs.

```
80 LPRINT CHR$(11);"FIFTH TAB."
```

Now when you run the program the first page looks just like before, but line 80 sends one more  $\langle VT \rangle$  than there are tabs. This doesn't confuse the printer — it advances the paper to the *next* tab position, which happens to be the first tab position on the next page.

There's a one-time vertical tab command that works just like the one-time horizontal tab command. Try this program to see how these commands work.

```
10 ' Demo of print positions
20 LPRINT "* 1st Line, 1st Column"
30 LPRINT CHR$(27);"f1";CHR$(3);
40 LPRINT "* 4th Line, 1st Column"
50 LPRINT CHR$(27);"f0";CHR$(7);
60 LPRINT "* 5th Line, 7th Column"
70 LPRINT CHR$(27);"f1";CHR$(3);
80 LPRINT CHR$(27);"f0";CHR$(5);
90 LPRINT "* 8th Line, 5th Column"
100 END
```

In this program, line 30 sends a one-time vertical tab with  $\langle ESC \rangle$  "f" 1 command. Line 50 sends a one-time horizontal tab with  $\langle ESC \rangle$  "f" 0 command. Finally, line 70 and line 80 send one-time vertical tab and one-time horizontal tab, so the line 90 prints text at the specified position.

```
* 1st Line, 1st Column.
```

```
* 4th Line, 1st Column.
  * 5th Line, 7th Column.
```

```
* 8th Line, 5th Column.
```



**Table 5-10**  
**Vertical tab commands**

Function	Control code
Advance paper to next tab position	CHR\$(11)
Set vertical tabs at $n1$ , $n2$ , etc.	<ESC> "B" CHR\$( $n1$ ) CHR\$( $n2$ ) ..... CHR\$(0)
Set vertical tabs every $n$ lines	<ESC> "e" 1 CHR\$( $n$ )
One-time vertical tab	<ESC> "f" 1 CHR\$( $n$ )

#### ■ Vertical tab channels

Vertical tab channels are especially helpful in two situations. The first occurs when you are writing a program to accompany a preprinted form that can accommodate various types of responses. The second occurs when you create a multipage form or report with different vertical tabs on each page.

**Table 5-11**  
**Vertical tab channel commands**

Function	Control code
Set vertical tabs at $n1$ , $n2$ , etc. as channel $n0$	<ESC> "b" CHR\$( $n0$ ) CHR\$( $n1$ ) CHR\$( $n2$ ) ..... CHR\$(0)
Select vertical channel $n0$	<ESC> "l" CHR\$( $n0$ )

You can store up to eight channels of tab stops. They are numbered from 0 to 7. If you have already stored a set using <ESC> "B" command, your printer has labelled it as channel 0.

Try this program how to see the vertical tab channels work.

```

10 ' Demo of vertical tab channels
20 LPRINT CHR$(27);"b";CHR$(1);CHR$(10);CHR$(20);
   CHR$(0);
30 LPRINT CHR$(27);"b";CHR$(2);CHR$(15);CHR$(25);
   CHR$(0);
40 LPRINT CHR$(27);"b";CHR$(3);CHR$(17);CHR$(28);
   CHR$(0);
50 ' Use vertical tab channels
60 FOR I=1 TO 3
70 LPRINT "TOP OF FORM"
80 LPRINT CHR$(27);"/";CHR$(I);
90 LPRINT CHR$(11);
100 LPRINT "1ST TAB OF CHANNEL";I
110 LPRINT CHR$(11);
120 LPRINT "2ND TAB OF CHANNEL";I

```

```

130 LPRINT CHR$(12);
140 NEXT I
150 LPRINT CHR$(27);"@"
160 END

```

When you run this program the printout should look like this.

TOP OF FORM	TOP OF FORM	TOP OF FORM
1ST TAB OF CHANNEL 1		
	1ST TAB OF CHANNEL 2	
2ND TAB OF CHANNEL 1		1ST TAB OF CHANNEL 3
	2ND TAB OF CHANNEL 2	
		2ND TAB OF CHANNEL 3

In this program we set tabs at 10 and 20 in channel 1 in line 20. In line 30 we set tabs 15 and 25 in channel 2, and in line 40 we set tabs 17 and 28 in channel 3.

Because the channels are stored, you must make the printer to recall one before you use it, so we used `<ESC> "/" CHR$(n0)` in line 80.

## CENTERING AND ALIGNING TEXT

Text can be arranged in any of three formats: left aligned or left-justified (normal printing with "ragged" right margin), centered between the margins, or right aligned (right-justified). These are selected by the following commands:

**Table 5-12**  
**Alignment commands**

Function	Control code
Left-justified printing	<ESC> "a" CHR\$(0)
Centered printing	<ESC> "a" CHR\$(1)
Right-justified printing	<ESC> "a" CHR\$(2)

Try this program to see how easy it is.

```
10 ' Demo of aligning and centering
20 LPRINT CHR$(27);"l";CHR$(20);
30 LPRINT CHR$(27);"Q";CHR$(60);
40 LPRINT CHR$(27);"a";CHR$(0);
50 LPRINT "THIS LINE IS LEFT-ALIGNED."
60 LPRINT CHR$(27);"a";CHR$(1);
70 LPRINT "THIS LINE IS CENTERED."
80 LPRINT CHR$(27);"a";CHR$(2);
90 LPRINT "THIS LINE IS RIGHT-ALIGNED."
```

When you run this program, you should get like this:

```
THIS LINE IS LEFT-ALIGNED.
      THIS LINE IS CENTERED.
                THIS LINE IS RIGHT-ALIGNED.
```

## MEMO

---

---

# CHAPTER 6

## SPECIAL FEATURES OF THE PRINTER

---

---

Subjects covered in Chapter 6 include—

- **Printer's bell**
- **Master reset**
- **Uni-directional printing**
- **International character sets**
- **Printing BIG characters**
- **The optional sheet feeder**
- **Macro instruction**
- **Reading a hex dump**

In the previous chapters we have learned about several groups of control codes. In this chapter we will look at more control codes. These codes don't fit neatly into any of the groupings that we have looked at so far, but they add a lot of useful features to your printer.

■ Now hear this

You may have heard the printer's *bell* if you have ever run out of paper. And you may have wondered why it's called a bell when it *beeps* instead of ringing! It's a long story that goes back to the early days of computers, when teletype machines were used for computer terminals. These mechanical marvels were equipped with a bell that could be heard for blocks. This bell was used to signal the operator that something needed attention. The code that the computer sent to the teletype machine to ring the bell was, reasonably enough, called a *bell code*. The name *bell code* is still with us, even if the bell has changed to a beeper, and a lot of people still call the beeper a bell, even if it doesn't sound like one.

The code to sound the "bell" is `CHR$(7)`, which is ASCII code 7 or `<BEL>`. Any time your printer receives this code it will sound the bell for a quarter of a second. This can be used to re-

mind the operator to change the paper or to make other adjustments to the printer.

You can try this by typing:

```
LPRINT CHR$(7)
```

### ■ Resetting the printer

Up to now when we wanted to reset the printer to the power on condition we have had to either turn the printer off and on again, or to send the specific codes that reset the particular features. There is an easier way. The control code `<ESC> “@”` will reset all of the printer’s features to the power on condition (as determined by the DIP switches), with two exceptions. The exceptions are that `<ESC> “@”` will not erase any characters that you have stored in the printer’s RAM memory (Chapter 7 tells you how to create your own characters), and it won’t erase a macro if you have one stored in the printer’s RAM (this chapter will tell you how to create a macro).

In addition, if you set the “Panel” modes by the control panel settings at power on, these functions will remain with this control code.

### ■ Taking the printer off line

You know how to put your printer *off line* with the On Line key on the control panel. The printer has another *off line* state that can be controlled from the computer. When you turn the printer *off line* from the computer, the printer will ignore anything that you send it, except for the code to go *on line* again. `CHR$(19)` is the code to turn the printer off line; `CHR$(17)` turns the printer back to on line status.

### ■ Printing the bottom of the sheet

Sometimes when you are using individual sheets of paper you may want to print near the bottom of a sheet. The paper-out detector usually stops the printer when you are about 1 inch from the bottom of the sheet. This is to notify you if you are running out of continuous paper.

Your printer has the ability to print right to the bottom of the sheet. You can disable the paper-out detector so that it doesn’t stop the printer. This will allow you to print to the end of the sheet, and even beyond if you are not careful. The codes to con-

trol the paper-out detector, along with the other codes that we have just looked at are in the following table.

**Table 6-1**  
**Some miscellaneous commands**

Function	Control code
Sound bell	CHR\$(7)
Master rest	<ESC> "@"
Off line	CHR\$(19)
On line	CHR\$(17)
Paper-out detector off	<ESC> "8"
Paper-out detector on	<ESC> "9"
Move print head back one space	CHR\$(8)
Delete last character sent	CHR\$(127)
Cancel text in print buffer	CHR\$(24)
Print "slash zero"	<ESC> "~" 1
Print "normal zero"	<ESC> "~" 0
Immediate-print on	<ESC> "i" 1
Immediate-print off	<ESC> "i" 0
Add <i>n</i> dot spaces between characters	<ESC> CHR\$(32) CHR\$( <i>n</i> )

■ Backspace, delete, and cancel text

Backspace (CHR\$(8)) "backs up" the print head so that you can print two characters right on top of each other. Each time your printer receives a backspace it moves the print head one character to the left, instead of to the right. You can *strike over* multiple letters by sending more than one backspace code.

Delete (CHR\$(127)) also "backs up" one character, but then it "erases" the previous character (it's erased from your printer's buffer, not from the paper).

Cancel text (CHR\$(24)) deletes all the text in the print buffer; that is, in the line before the delete text command. Since your printer prints one line of text at a time, only that line will be deleted.

The following program shows how these codes work.

```

10 LPRINT "BACKSPACE DOES NOT";
20 LPRINT CHR$(8);CHR$(8);CHR$(8);
30 LPRINT "=== WORK"
40 LPRINT "DELETE DOES NOT";
50 LPRINT CHR$(127);CHR$(127);CHR$(127);
60 LPRINT "WORK"
70 LPRINT "CANCEL LINE";

```

```
80 LPRINT CHR$(24);  
90 LPRINT "DOES NOT WORK"
```

Here is what this program will print:

```
BACKSPACE DOES NOT WORK  
DELETE DOES WORK  
DOES NOT WORK
```

The backspace codes in line 20 move the print head a total of three spaces to the left so that the first part of line 30 will overprint the word "NOT". The delete codes in line 50 "erase" the three letters in the word "NOT" so that it doesn't even print.

In line 80, CHR\$(24) deletes the words in line 70. The semicolon at the end of line 70 prevents a line feed from causing that line to print before the printer receives the CHR\$(24) code. The text in line 90 prints as it normally would because it is after CHR\$(24).

#### ■ Printing zeroes

There are two types of zeroes. There is the one we use every day — 0 — and this is what your printer will print as its default.

The other type is used almost exclusively in computers and engineering. It is called the "slash zero" and is written like this — 0. The line through the number prevents you from misreading it as the letter "O". Before high-quality printers were available, this was a good idea but there is no special need for it today (although you may want to use the slash zero for a special effect).

#### ■ Immediate-print

This printer can print at the quick rate of 120 characters per second. But it will also print more slowly at the speed of your typing. In the *immediate-print* mode, the print head prints one character at a time, as you send it. The printer also moves the paper up so that you can see the current line and then down to continue printing.

You can turn the immediate-print mode on with <ESC> "i" 1. Before looking at it, let's review the normal operation of the print buffer. Enter this program.



```
20 A$="" : INPUT " TYPE A CHARACTER ",A$
30 IF A$="" THEN 50
40 LPRINT A$; : GOTO 20
50 LPRINT : LPRINT CHR$(27);"@"
```

Now type several characters, and after each press the RETURN key. The printer simply puts the characters into its buffer while it waits for a carriage return code. (In this program the RETURN key doesn't send a carriage return code.) To end this program and print the contents of the buffer, press RETURN alone.

Now add this line:

```
10 LPRINT CHR$(27);"i1";
```

And RUN the program. Your printer will now respond to your typing — immediately.

When you are finished, press RETURN alone.

#### ■ Adjusting the width of space between characters

This printer provides a command that adjusts the space between all the characters that it prints when the DIP switch 2-5 is set on. The `<ESC> CHR$(32) CHR$(n)` command adds blank space between the characters. The units of space that are added vary in 1/240-inch units.

Try this program to see how this works.

```
10 ' Demo of adjusting spaces
20 LPRINT CHR$(27);"x1";
30 FOR I=10 TO 1 STEP -2
40 LPRINT CHR$(27);" ";CHR$(I);
50 LPRINT "This line is added";I;"spaces."
60 NEXT I
70 LPRINT "This line is Normal space."
80 END
```

This line is added 10 spaces .  
 This line is added 8 spaces .  
 This line is added 6 spaces .  
 This line is added 4 spaces .  
 This line is added 2 spaces .  
 This line is Normal space .

This command can be used to produce micro-justification, which is a method of justifying lines by increasing the space between each character.

### ■ Uni-directional printing

Uni-directional printing means *printing in one direction only*. Your printer normally prints when the print head is moving in both directions. But once in a while you may have an application such as making tables where you are more concerned with how the vertical lines align than with how fast it prints. The printer lets you make this choice. The table below shows the commands for controlling how the printer prints.

**Table 6-2**  
**Printing direction commands**

Function	Control code
Print in one direction	<ESC> "U" 1
Print in both directions	<ESC> "U" 0
One time print in one direction	<ESC> "<"

Try this program to see the difference that printing in one direction makes.

```

10 ' Demo of uni-directional printing
20 LPRINT CHR$(27);"1";
30 FOR I=1 TO 10
40 LPRINT "!"
50 NEXT I
60 LPRINT : LPRINT
70 LPRINT CHR$(27);"U1";
80 FOR I=1 TO 10
90 LPRINT "!"
100 NEXT I
110 LPRINT CHR$(12);CHR$(27);"@"

```

Here is what you will get. The top line is printed bi-directionally, and the bottom is printed uni-directionally. You will have to look hard because there isn't much difference, but the bottom vertical lines are perfectly aligned.

Let's analyze the program. Line 20 defines the line spacing to  $7/72$  of an inch so that the characters that we print will touch top to bottom. Lines 30 ~ 50 print 10 vertical line characters. Then line 70 sets uni-directional printing and the vertical lines are printed again. Finally line 110 sends a form feed to advance the paper to the top of a new page, and then uses the master reset to restore the printer to the power on condition.

You can also set the printer to print in one direction for one line only by using the `<ESC> "<` command. This command immediately moves the print head to the left margin and then prints the remainder of the line from left to right.

#### ■ The seven bit dilemma

Some computers (not the IBM-PC fortunately!) don't have the capability to send eight bits on their parallel interface, but can only send seven bits. This would make it impossible for these computers to use this printer's block graphics characters and special symbols if our engineers hadn't thought of a solution. (All of these characters have ASCII codes greater than 127 which means that the eighth bit must be on to use them.) The solution lies in the three control codes given in the following table:

**Table 6-3**  
**Eighth bit controls**

Function	Control code
Turn the eighth bit ON	<ESC> ">"
Turn the eighth bit OFF	<ESC> "="
Accept the eighth bit "as is" from the computer	<ESC> "#"

■ Block graphics characters and special symbols

Besides the upper and lower case letters and symbols that we are by now familiar with, your printer has a whole different set of characters that are for special uses. These characters include block graphics for drawing forms and graphs, and special symbols for mathematical, engineering and professional uses. The special characters are included in two character sets. The character set you normally use with the IBM mode is called character set #1. The special characters are printed out when you send ASCII codes 160 ~ 255 to the printer.

Your printer also offers character set #2 which is almost the same as character set #1 except for the addition of ASCII codes 3 ~ 6, 21, and 128 ~ 159. Character set #2 is selected with <ESC> "6"; to go back to character set #1, use <ESC> "7".

You can also specify the power-on default character set by setting DIP switch 1-7 on for character set #1 and off for character set #2 while the DIP switch 2-5 is set off. The following program will print out all of the graphics characters available:

```

10 LPRINT CHR$(27);"0";
20 LPRINT CHR$(27);"6";
30 FOR I=3 TO 6
40 LPRINT " ";J;CHR$(J);CHR$(9);
50 NEXT J
60 LPRINT " 21 ";CHR$(21)
70 LPRINT
80 FOR J=128 TO 254 STEP 5
90 FOR I=J TO J+4
95 IF I>254 THEN 110
100 LPRINT I;CHR$(I);CHR$(9);
110 NEXT I
120 LPRINT : LPRINT
130 NEXT J

```

Figure 6-1 shows what this program will print. If your chart doesn't look like this because it has regular letters and numbers instead of the special symbols, then your computer is only using seven bits (unless you have set DIP switch 2-5 on by mistake). You can get the correct printout by changing line 100 to this:

```
100 LPRINT I;CHR$(27);">";CHR$(I);CHR$(27);"="";
      CHR$(9);
```

3	¥	4	ı	5	ı	6	ı	21	ı
128	ı	129	ı	130	ı	131	ı	132	ı
133	ı	134	ı	135	ı	136	ı	137	ı
138	ı	139	ı	140	ı	141	ı	142	ı
143	ı	144	ı	145	ı	146	ı	147	ı
148	ı	149	ı	150	ı	151	ı	152	ı
153	ı	154	ı	155	ı	156	ı	157	ı
158	ı	159	ı	160	ı	161	ı	162	ı
163	ı	164	ı	165	ı	166	ı	167	ı
168	ı	169	ı	170	ı	171	ı	172	ı
173	ı	174	ı	175	ı	176	ı	177	ı
178	ı	179	ı	180	ı	181	ı	182	ı
183	ı	184	ı	185	ı	186	ı	187	ı
188	ı	189	ı	190	ı	191	ı	192	ı
193	ı	194	ı	195	ı	196	ı	197	ı
198	ı	199	ı	200	ı	201	ı	202	ı
203	ı	204	ı	205	ı	206	ı	207	ı
208	ı	209	ı	210	ı	211	ı	212	ı
213	ı	214	ı	215	ı	216	ı	217	ı
218	ı	219	ı	220	ı	221	ı	222	ı
223	ı	224	ı	225	ı	226	ı	227	ı
228	ı	229	ı	230	ı	231	ı	232	ı
233	ı	234	ı	235	ı	236	ı	237	ı
238	ı	239	ı	240	ı	241	ı	242	ı
243	ı	244	ı	245	ı	246	ı	247	ı
248	ı	249	ı	250	ı	251	ı	252	ı
253	ı	254	ı						

Figure 6-1. Character set #2

So how are all of these characters used? Here is a program that demonstrate how the graphics characters can be combined to create a figure: the 5 of clubs.

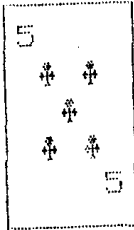
```
10 LPRINT CHR$(27);"6";
20 LPRINT CHR$(218);CHR$(196);CHR$(196);CHR$(196);
   CHR$(196);CHR$(196);CHR$(191)
30 LPRINT CHR$(179);CHR$(53);CHR$(32);CHR$(32);
   CHR$(32);CHR$(32);CHR$(179)
40 LPRINT CHR$(179);CHR$(32);CHR$(5);CHR$(32);
   CHR$(5);CHR$(32);CHR$(179)
50 LPRINT CHR$(179);CHR$(32);CHR$(32);CHR$(5);
   CHR$(32);CHR$(32);CHR$(179)
60 LPRINT CHR$(179);CHR$(32);CHR$(5);CHR$(32);
   CHR$(5);CHR$(32);CHR$(179)
70 LPRINT CHR$(179);CHR$(32);CHR$(32);CHR$(32);
   CHR$(32);CHR$(53);CHR$(179)
80 LPRINT CHR$(192);CHR$(196);CHR$(196);CHR$(196);
   CHR$(196);CHR$(196);CHR$(217)
90 LPRINT CHR$(27);"7"
```

If you have a 7-bit interface, add the following lines to the program given above:

```
15 LPRINT CHR$(27);">";
95 LPRINT CHR$(27);"="
```

In this program, line 10 selects character set #2 so that all the graphics characters can be used (including the "club" symbol). Then lines 20 ~ 80 print the 5 of clubs figure. Line 90 cancels character set #2 (which is the same as selecting character set #1).

Here is what this program prints:



### ■ International character sets

Your printer changes languages by changing 12 characters that are different in the different languages. These sets of characters are called *international character sets* – and there are 11 sets in all. The control codes to select the international character sets are given in Table 6-4.

**Table 6-4**  
**International character set commands**

Country	Control code
U.S.A.	<ESC> "R" CHR\$(0)
France	<ESC> "R" CHR\$(1)
Germany	<ESC> "R" CHR\$(2)
England	<ESC> "R" CHR\$(3)
Denmark type I	<ESC> "R" CHR\$(4)
Sweden	<ESC> "R" CHR\$(5)
Italy	<ESC> "R" CHR\$(6)
Spain	<ESC> "R" CHR\$(7)
Japan	<ESC> "R" CHR\$(8)
Norway	<ESC> "R" CHR\$(9)
Denmark type II	<ESC> "R" CHR\$(10)

The characters that change are shown beneath their ASCII code in Table 6-5.

**Table 6-5**  
**International character sets**

Country	35	36	64	91	92	93	94	96	123	124	125	126
U.S.A	#	\$	@	[	\	]	^	`	{		}	~
France	#	\$	à	°	ç	§	^	`	é	ù	è	¨
Germany	#	\$	§	Ä	Ö	Ü	^	`	ä	ö	ü	ß
England	£	\$	@	[	\	]	^	`	{		}	~
Demark type I	#	\$	@	Æ	Ø	Å	^	`	æ	ø	å	~
Sweden	#	¤	É	Ä	Ö	Å	Û	é	ä	ö	å	ü
Italy	#	\$	@	°	\	é	^	ù	à	ò	è	ì
Spain	₧	\$	@	í	ñ	¿	^	`	ñ	}	~	
Japan	#	\$	@	[	¥	]	^	`	{		}	~
Norway	#	¤	É	Æ	Ø	Å	Û	é	æ	ø	å	ü
Denmark type II	#	\$	É	Æ	Ø	Å	Û	é	æ	ø	å	ü

■ **Printing characters in the control code area**

When you refer the Appendix B, you'll find many characters are printed in the control code area. (Remember that the low-order control codes are the ASCII codes 0 through 31 plus 127, and the high-order control codes are 128 through 159 plus 255.)

These codes don't normally print symbols on paper, rather they cause the printer to change modes. To make them print as normal symbols requires an extra command. For example, the command to "normalize" the high-order control codes is <ESC> "6". Try this program with the DIP switch 2-5 on.

```

10 ' Demo of characters in the high-control code
    area
20 LPRINT CHR$(27);"6";
30 FOR I=128 TO 159
40 LPRINT CHR$(I);
50 NEXT I
60 LPRINT CHR$(27);"7"
70 END

```

When you run this program you'll get like this:

```

àéùòì°ÉÌÑ§¤ÆÅç§§ÆxØø"ÀÖÜåÜÉÉ¥

```



That's where the italic international characters have been stored. So the `<ESC> "6"` command without the `<ESC> "R"` gives you access to the international characters. The `<ESC> "7"` turns these characters back into control codes.

The low-order control codes can also be defined, but not all of them can be printed easily. The `<ESC> "I" 1` command makes them printable, and the `<ESC> "I" 0` returns them to normal.

Just as the higher control codes hide the italic international characters, the lower control codes hide the roman international characters.

Let's see how these commands work with the following program:

```

10 ' Demo of characters in the control code area
20 LPRINT CHR$(27);"I1";
30 FOR I=0 TO 6
40 LPRINT CHR$(I);
50 NEXT I
60 LPRINT CHR$(16);CHR$(17);
70 FOR I=21 TO 31
80 LPRINT CHR$(I);
90 NEXT I
100 LPRINT
110 FOR I=128 TO 134
120 LPRINT CHR$(I);
130 NEXT I
140 LPRINT CHR$(144);CHR$(145);
150 FOR I=149 TO 159
160 LPRINT CHR$(I);
170 NEXT I
180 LPRINT CHR$(27);"I0"
190 END

```

When you run this program you should get like this:

```

àèùòì*E$ßø"ÀÖÜäüéé¥
àèùòì*E$ßø"ÀÖÜäüéé#

```

**Table 6-6**  
**Control code area commands**

<b>Function</b>	<b>Control code</b>
Printable code area expansion	<ESC> "6"
Control code area expansion	<ESC> "7"
Select undefined codes as characters	<ESC> "I" 1
Cancel undefined codes as characters	<ESC> "I" 0

■ **Printing BIG characters**

You can even enlarge your character sets for attention-grabbing headings or special effects. There are six commands you can use. Everything following any of them will be enlarged as shown below, until the cancel code is entered.

**Table 6-7**  
**Big character commands**

<b>Function</b>	<b>Control code</b>
Double-high enlarged print	<ESC> "h" CHR\$(1)
Quad-high enlarged print	<ESC> "h" CHR\$(2)
Double-high lower-half enlarged print	<ESC> "h" CHR\$(3)
Double-high upper-half enlarged print	<ESC> "h" CHR\$(4)
Quad-high lower-half enlarged print	<ESC> "h" CHR\$(5)
Quad-high upper-half enlarged print	<ESC> "h" CHR\$(6)
Cancel enlarged print	<ESC> "h" CHR\$(0)

Try this program to see the big characters.

```

10 ' Demo of BIG characters
20 LPRINT "THIS IS ";
30 LPRINT CHR$(27);"h";CHR$(1);
40 LPRINT "DOUBLE";
50 LPRINT CHR$(27);"h";CHR$(0);
60 LPRINT " SIZED PRINTING."
70 LPRINT
80 LPRINT "THIS IS ";

```

```
90 LPRINT CHR$(27);"h";CHR$(2);
100 LPRINT "QUAD";
110 LPRINT CHR$(27);"h";CHR$(0);
120 LPRINT " SIZED PRINTING."
130 END
```

When you run this program, you will get like this:

```
THIS IS DOUBLE SIZED PRINTING.
THIS IS QUAD SIZED PRINTING.
```

As you can see, when the big character command is used, the baseline for each character does not align. If you want to align the baseline, try this program:

```
10 ' Demo of aligning BIG characters
20 LPRINT "THIS IS ";
30 LPRINT CHR$(27);"j";CHR$(21);
40 LPRINT CHR$(27);"h";CHR$(1);
50 LPRINT "DOUBLE";
60 LPRINT CHR$(27);"h";CHR$(0);
70 LPRINT CHR$(27);"J";CHR$(18);
80 LPRINT " SIZED PRINTING."
90 LPRINT :LPRINT :LPRINT
100 LPRINT "THIS IS ";
110 LPRINT CHR$(27);"j";CHR$(63);
120 LPRINT CHR$(27);"h";CHR$(2);
130 LPRINT "QUAD";
140 LPRINT CHR$(27);"h";CHR$(0);
150 LPRINT CHR$(27);"J";CHR$(63);
160 LPRINT " SIZED PRINTING."
170 LPRINT :LPRINT
180 END
```

THIS IS DOUBLE SIZED PRINTING.

THIS IS QUAD SIZED PRINTING.

### ■ The optional sheet feeder

The automatic sheet feeder is a handy option that feeds single cut sheets automatically. Work done on cut sheets looks better than done on computer paper, and you don't have to tear the "perforations" off each sheet as you must with fan-fold paper.

The automatic sheet feeder feeds a new sheet automatically every time the printer receives or generates a form feed. Any time you wish, you can turn the auto-feed unit on and off by using control codes.

**Table 6-8**  
**Automatic sheet feeder commands**

Function	Control code
Select automatic feed mode	<ESC> CHR\$(25) CHR\$(4) or "((4))"
Cancel automatic feed mode	<ESC> CHR\$(25) CHR\$(0) or "((0))"
Insert paper	<ESC> CHR\$(25) CHR\$(1) or "((1))"
Eject paper	<ESC> CHR\$(25) "R" or "((R))"

When the automatic sheet feeder is installed, you must set DIP switch 1-5 on to detect the paper-out condition.

In addition, the following functions are ignored when the automatic sheet feeder is installed:

- Setting of the page length
- Top and bottom margins
- Vertical tab settings

### ■ The macro control code

The last of our group of miscellaneous codes is definitely not the least. It is a *user-defined* control code, called a *macro* control code. The term *macro* is from the jargonese *macro-instruction* which refers to an instruction that "calls," or uses a group of normal instructions. In computer programming macro-instructions (which are similar to subroutines) save programmers a lot of time and effort. Your printer's macro can save you a lot of time and effort also.

Here is how the printer's macro works. You *define a macro* by telling the printer what normal control codes are to be included in the macro. Then you can use the macro any time that you want and the printer will do all the things that you included in the macro definition. You can include up to 16 codes in a single macro. You can even use the macro to store a frequently used word or phrase. There are two control codes for the macro: one to define it, and one to use it. They are given in the Table 6-9.

**Table 6-9**  
**Macro instruction commands**

Function	Control code
Define macro	<ESC> "+" ... (codes you include) ... CHR\$(30)
Use macro	<ESC> "+" CHR\$(1)

To see how this works we can build a macro that will reset the printing style to normal, no matter what style it may be to start with. The following program will define a macro to do this.

```

10 LPRINT CHR$(27);"+";           'Start macro
20 LPRINT CHR$(27);"h";CHR$(0);   'Big character off
30 LPRINT CHR$(27);"!";CHR$(0);   'Select normal pica
40 LPRINT CHR$(27);"T";           'Super & subscripts
    off
50 LPRINT CHR$(27);"a";CHR$(0);   'Left-aligned
    printing
60 LPRINT CHR$(30)                 'End macro
    definition

```

As the comments in the program shown, we started to define the macro in line 10. Line 20 cancels big character printing. Line 30 sets normal pica, and this command also cancels proportional pitch, condensed print, expanded print, boldface, emphasized, italics, and underlining. Line 40 cancels superscripts and subscripts, and line 50 sets left-justified printing. Then, line 60 ends the macro definition. This printer will remember this macro until the power is turned off or until a new macro is defined. A macro can hold up to 16 bytes (characters) of information. The one that we defined contains eleven.

Now that you have defined a macro, let's see how to use it.

This program will print one line using several printing features. Then it "calls" the macro in line 60. When line 80 prints the style is "plain vanilla" because the macro has reset it.

```
10 LPRINT CHR$(27);"Q";CHR$(40);
20 LPRINT CHR$(27);"a";CHR$(2);
30 LPRINT CHR$(27);"-1";
40 LPRINT CHR$(27);"h";CHR$(1);
50 LPRINT "TESTING ABCD"
60 LPRINT CHR$(27);"+";CHR$(1);
70 LPRINT "TESTING ABCD"
80 END
```

```
TESTING ABCD
```

TESTING ABCD

#### ■ Reading a hex dump

The BASIC in some computers changes ASCII codes before they send them to the printer. If you run into problem because of this, try this hex dump to check the ASCII codes.

First turn off the printer. Hold down both the Paper Feed key and Mode key and turn on the printer, and run the following program.

```
10 FOR I=0 TO 255
20 LPRINT CHR$(I);
30 NEXT I
40 LPRINT
50 END
```

If your system passes the codes directly to the printer without changing them, you will get a printout like this. (You can print out the last remaining line in the print buffer by putting the printer off line with the On Line key.)

00	01	02	03	04	05	06	07	08	09	0A	0B	0C	0D	0E	0F	.....
10	11	12	13	14	15	16	17	18	19	1A	1B	1C	1D	1E	1F	.....
20	21	22	23	24	25	26	27	28	29	2A	2B	2C	2D	2E	2F	!\"#\$%&'()*+,-./
30	31	32	33	34	35	36	37	38	39	3A	3B	3C	3D	3E	3F	0123456789:;<=>?
40	41	42	43	44	45	46	47	48	49	4A	4B	4C	4D	4E	4F	@ABCDEFGHIJKLMNO
50	51	52	53	54	55	56	57	58	59	5A	5B	5C	5D	5E	5F	PQRSTUVWXYZ[\]^_
60	61	62	63	64	65	66	67	68	69	6A	6B	6C	6D	6E	6F	`abcdefghijklmnopqrstuvwxyz{ }~.
70	71	72	73	74	75	76	77	78	79	7A	7B	7C	7D	7E	7F	.....
80	81	82	83	84	85	86	87	88	89	8A	8B	8C	8D	8E	8F	.....
90	91	92	93	94	95	96	97	98	99	9A	9B	9C	9D	9E	9F	.....
A0	A1	A2	A3	A4	A5	A6	A7	A8	A9	AA	AB	AC	AD	AE	AF	.....
B0	B1	B2	B3	B4	B5	B6	B7	B8	B9	BA	BB	BC	BD	BE	BF	.....
C0	C1	C2	C3	C4	C5	C6	C7	C8	C9	CA	CB	CC	CD	CE	CF	.....
D0	D1	D2	D3	D4	D5	D6	D7	D8	D9	DA	DB	DC	DD	DE	DF	.....
E0	E1	E2	E3	E4	E5	E6	E7	E8	E9	EA	EB	EC	ED	EE	EF	.....
F0	F1	F2	F3	F4	F5	F6	F7	F8	F9	FA	FB	FC	FD	FE	FF	.....
0D	0A															..

Most BASICSs, however, are not quite that straight forward. For example, the IBM-PC prints the following:

00	01	02	03	04	05	06	07	08	09	0A	0B	0C	0D	0A	0E	.....
0F	10	11	12	13	14	15	16	17	18	19	1B	1C	1D	1E	1F	.....
20	21	22	23	24	25	26	27	28	29	2A	2B	2C	2D	2E	2F	!\"#\$%&'()*+,-./
30	31	32	33	34	35	36	37	38	39	3A	3B	3C	3D	3E	3F	0123456789:;<=>?
40	41	42	43	44	45	46	47	48	49	4A	4B	4C	4D	4E	4F	@ABCDEFGHIJKLMNO
50	51	52	53	54	55	56	57	58	59	5A	5B	5C	5D	5E	5F	PQRSTUVWXYZ[\]^_
60	61	62	63	64	65	66	67	68	69	6A	6B	6C	6D	6E	6F	`abcdefghijklmnopqrstuvwxyz{ }~.
70	71	72	73	74	75	76	77	78	79	7A	7B	7C	7D	7E	7F	.....
80	81	82	83	84	85	86	87	88	89	8A	8B	8C	8D	8E	8F	.....
90	91	92	93	94	95	96	97	98	99	9A	9B	9C	9D	9E	9F	.....
A0	A1	A2	A3	A4	A5	A6	A7	A8	A9	AA	AB	AC	AD	AE	AF	.....
B0	B1	B2	B3	B4	B5	B6	B7	B8	B9	BA	BB	BC	BD	BE	BF	.....
C0	C1	C2	C3	C4	C5	C6	C7	C8	C9	CA	CB	CC	CD	CE	CF	.....
D0	D1	D2	D3	D4	D5	D6	D7	D8	D9	DA	DB	DC	DD	DE	DF	.....
E0	E1	E2	E3	E4	E5	E6	E7	E8	E9	EA	EB	EC	ED	EE	EF	.....
F0	F1	F2	F3	F4	F5	F6	F7	F8	F9	FA	FB	FC	FD	FE	FF	.....
0D	0A															..

Notice that your printer receives decimal code 13 (Hex 0D) together with hex 0A, which is really decimal 10. In addition, your printer does not receive decimal code 26 (hex 1A).

Your printer prints 16 hex numbers per line, printing the characters on the right hand side. If it receives less than 16, it sits in a holding pattern, awaiting more data. Taking the printer off line dumps the characters to the paper.

To debug a program quickly, just use the hex dump capability. Appendix B will help you translate the hex codes to ASCII equivalents.

## MEMO



---

---

# CHAPTER 7

## DOWNLOAD CHARACTERS AND DOT GRAPHICS

---

---

**Subjects covered in Chapter 7 include—**

- **Designing and printing your own characters**
- **User-designed graphics**

Using the procedures outlined so far, all of the printer's standard functions can be utilized. There are two additional user-defined functions available: designing and printing your own characters, and designing and printing your own dot graphics.

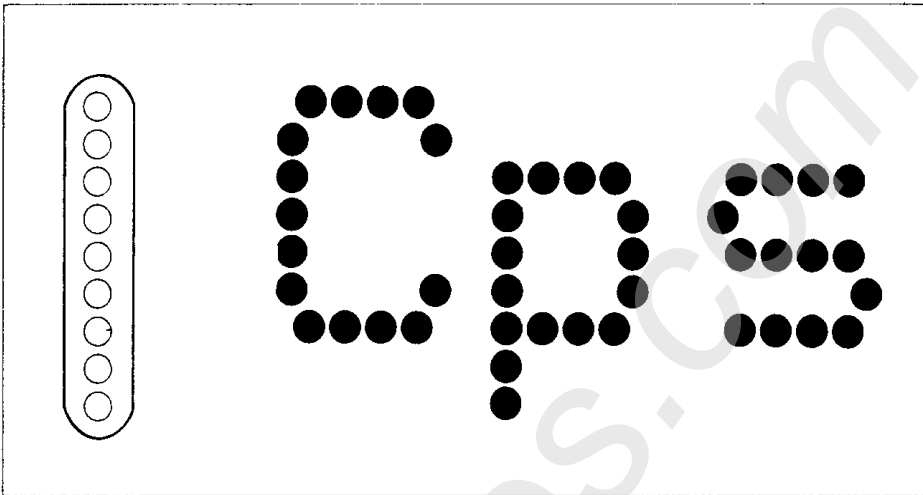
These two functions can be used to design and print any symbol, or any graphic shape. This allows you to make your own special symbols, or print a company logo. Some understanding of dot matrix technology will be useful.

### **DOT MATRIX PRINTING**

Dot matrix printers are named because each character is formed from a group of dots. The print head comprises nine wires or pins stacked vertically. For any standard character, up to seven of the pins are used at one time; for capital letters, the top seven are used, for standard height lower-case characters, the center five pins, and for "descending" characters (such as "p" or "g"), the bottom seven pins are used. The print head moves across the paper and at any instant prints a vertical series of dots; looking at Figure 7-1 will reveal that the letter "p" consists of five vertical columns of dots.

Any pin is fired by only one number, and any group of pins is fired by a different number. One byte of data (a decimal number from 0 to 255), can thus represent a unique combination of dots.

For example, if the data representing “1” was sent to the print head, only the bottom pin would fire; if “2” was sent, only the second pin from the bottom would fire, and if “3” was sent, the two bottom pins would fire, and so on. Columns of these dots side by side make all the characters.



**Figure 7-1.** As the print head moves across the page, each of the pins prints a row of dots.

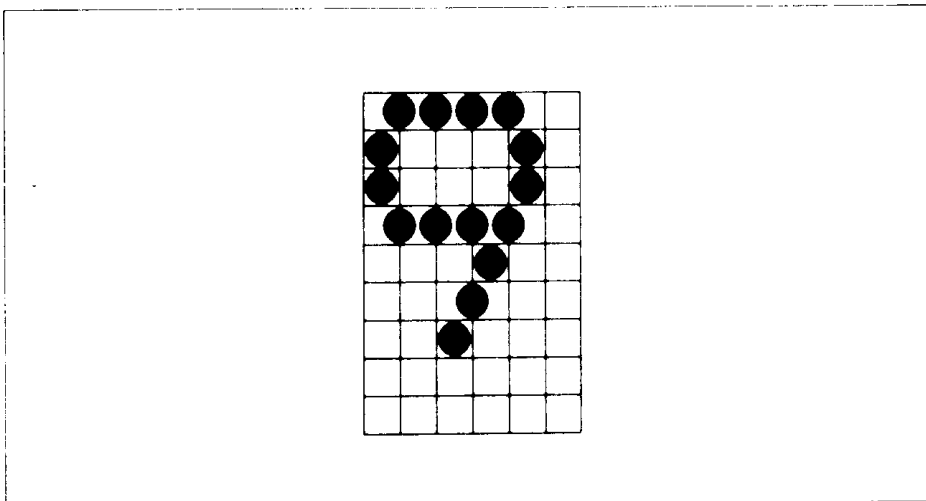
## DESIGNING YOUR OWN CHARACTERS

Standard characters are permanently stored in the printer's ROM (Read Only Memory), but characters you design are *downloaded* and stored in RAM (Random Access Memory) for use.

Designing and printing your own characters has two requirements: firstly, designing the shape of the character, calculating the data necessary to make the shape, and sending that data to the printer, and secondary, sending the command to print the downloaded characters instead of the standard characters. There are a number of design constraints for download draft quality characters:

- The matrix or grid on which you design the characters is six boxes wide by nine boxes high.
- Horizontally, dots may be centered in a box, or may straddle a line, making the actual character grid 11 dots wide by 9 dots high. Vertically, dots can only be centered in a box. See Figure 7-2.

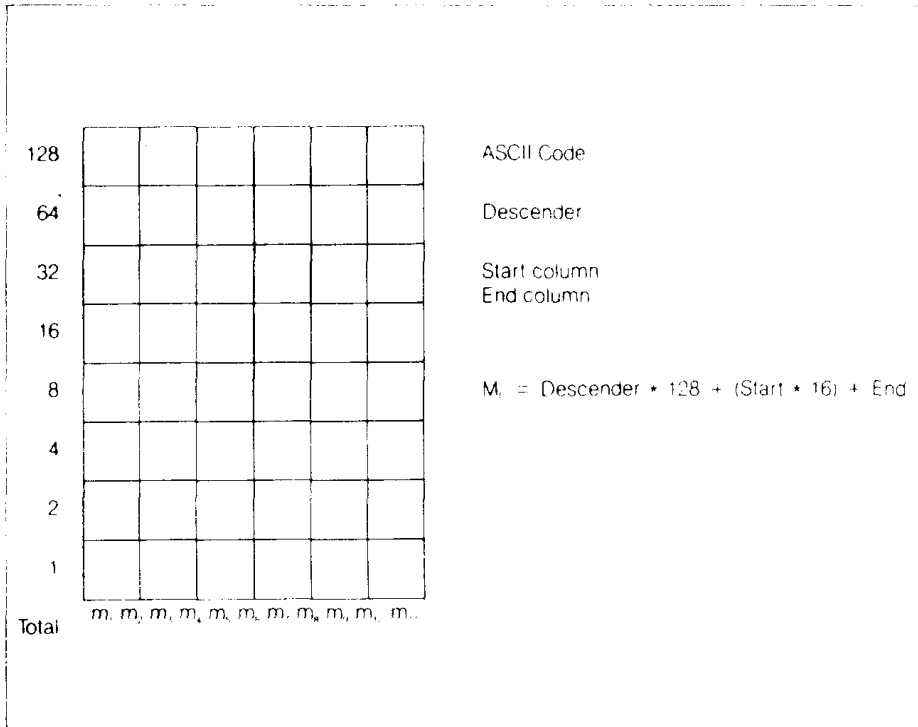
- The minimum width of a character is five dots.
- Unlike standard characters that are restricted to a height of seven dots, user-defined characters may use eight dots vertically.
- Dots cannot overlap — that is, you may not have a dot inside a box next to one that is on a line.
- You may define any position in the ASCII table, except the block graphics area when you are downloading in the IBM mode.



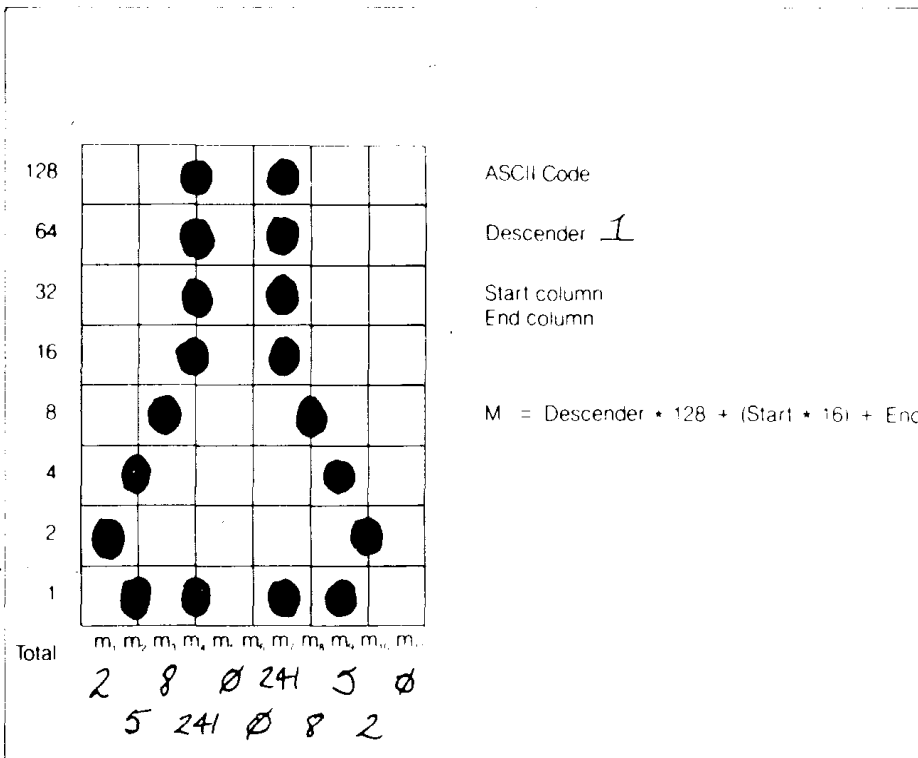
**Figure 7-2.** Dots can be inside boxes or straddle the vertical lines of the grid.

Photocopy the grid in Figure 7-3 to help design your new characters. We will use a tiny representation of a chemist's flask for our example. We decided that our flask will *not* be a “descender” (printing below the baseline of standard characters), so a figure “1” is written next to Descender on the grid. If your character is a descender, write a “0” next to Descender.

Next we calculate the *vertical* numerical values of the columns of dots, and enter them underneath the grid. For example, looking at Figure 7-4, we see that in the left-most column there is only one dot, and it is sitting in the “2” box. Thus its vertical value is 2. In the next column, there is a dot straddling the vertical line in the “1” box, and another in the “4” box; its value is recorded as 5.



**Figure 7-3.** Use this grid (or one similar to it) to define your own draft characters.



**Figure 7-4.** Add the values of the dots in each column and write the sum of each column at the bottom.

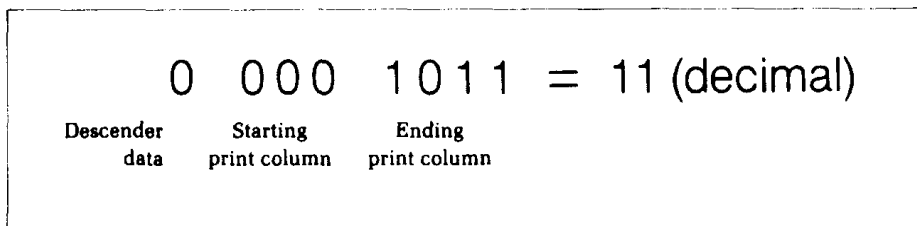
You will see the letters *m1*, *m2*, *m3* etc., are above your values. When you define the character, you will substitute your value for each of these letters.

Before you complete the definition, you will need to decide exactly where in the standard ASCII set you want to place your characters. After downloading, you access your new character by sending the code for the character you replaced. For example, we decided to assign our flask to the “<” character. You are not restricted in your choice of ASCII codes, so little-used codes may be replaced by your own more useful characters. The complete command syntax for a download character is:

```
<ESC> "&" CHR$(0) n1 n2 m0 m1 m2 m3 m4 m5 m6 m7 m8 m9
m10 m11
```

Where <ESC> is the escape code (CHR\$(27)), the “&” is the ampersand (CHR\$(38)) followed by CHR\$(0), and *n1* and *n2* specify the ASCII codes you want the new characters to occupy. *n1* specifies the beginning of the range of ASCII codes to be defined, and *n2* the end; if you only want to define one character, *n1* and *n2* will be the same.

*m0* is called the attribute byte, and describes two attributes: the top or high order bit describes whether the character is a descender, and the last seven bits describe proportional widths. Our character will occupy from column 1 to column 11, so the proportional data is 11. See Figure 7-5. For further detail about proportional width of characters, see the following section.



**Figure 7-5.** The attribute byte (*m0*) for our flask character.

Even though there are no dots in the last column, we define to column 11 to leave some space between the characters.

*m1* to *m11* are the column data we defined along the bottom of the grid; *m1* the left-most column value, *m2* the next, and so on. You must define eleven data, even if the last few data are 0. For the flask, the complete command will be:

```
CHR$(27);CHR$(38);CHR$(0);CHR$(60);CHR$(60);CHR$(139)
;CHR$(2);CHR$(5);CHR$(8);CHR$(241);CHR$(0);CHR$(0)
;CHR$(241);CHR$(8);CHR$(5);CHR$(2);CHR$(0)
```

Put this command into the appropriate syntax for the language you are using. Before you run the program and send the data to the printer, remember to check that DIP switch 2-1 is set to off.

The last requirement is the command to make the printer use the downloaded characters stored in RAM instead of the standard character set stored in ROM. The command is:

```
<ESC> “%” n
```

Where *n* is either “1” (CHR\$(49), to select), or “0” (CHR\$(48), to cancel). If you want your new characters to be included in a standard character set, you may copy the standard set stored in ROM into the download RAM, which will save you switching back and forth between the download area and the standard ROM. If you wish to use this option, make sure that you copy the standard characters into RAM **before** you download your own, because the last-copied characters replace previously copied ones. The command to copy the standard characters into the download RAM area is:

```
<ESC> “:” CHR$(0) CHR$(0) CHR$(0)
```

To recap, the order of commands if you wish to use various user-defined characters with the standard set is:

- Select the draft characters : <ESC> “x” 0
- Copy standard character set to RAM : <ESC> “:”  
CHR\$(0) CHR\$(0) CHR\$(0)
- Define characters, and send data to printer : <ESC> “&”  
CHR\$(0) .....
- Tell printer to use download character set : <ESC> “%”  
1

To demonstrate how to use the download characters, let’s use the “flask” character and some other user-defined characters to print a small graph. This program will do just that:

```
10 LPRINT CHR$(27);":":CHR$(0);CHR$(0);CHR$(0);
20 LPRINT CHR$(27);"&":CHR$(0);CHR$(60);CHR$(62);
30 FOR N=60 TO 62
40 FOR M=0 TO 11
50 READ MM
60 LPRINT CHR$(MM);
70 NEXT M
80 NEXT N
90 LPRINT
100 DATA 139, 2, 5, 8,241, 0, 0,241, 8, 5,
      2, 0
110 DATA 139,124, 0, 66, 4, 64, 36, 16, 2, 16,
      12, 0
120 DATA 139, 46, 16, 2, 60, 0, 48, 0, 48, 0,
      48, 0
130 LPRINT CHR$(27);"D";CHR$(11);CHR$(0)
140 LPRINT CHR$(27);"h";CHR$(1);
150 LPRINT " U.S. EXPORTS"
160 LPRINT CHR$(27);"h";CHR$(0);
170 LPRINT CHR$(27);"%1";
180 LPRINT "AUTOS";CHR$(9);
190 FOR I=.4 TO 9.3 STEP .4
200 LPRINT CHR$(61);
210 NEXT I
220 LPRINT
230 LPRINT "CHEMICALS";CHR$(9);
240 FOR I=.4 TO 8.7 STEP .4
250 LPRINT CHR$(60);
260 NEXT I
270 LPRINT
280 LPRINT "GUNS";CHR$(9);
290 FOR I=.4 TO 1.4 STEP .4
300 LPRINT CHR$(62);
310 NEXT I
320 LPRINT
330 LPRINT CHR$(9);"+--";
340 SCALE$="--+--"
350 FOR I=2 TO 8 STEP 2
360 LPRINT SCALE$;
370 NEXT I
380 LPRINT "--+"
390 LPRINT CHR$(9);" ";
400 FOR I=2 TO 8 STEP 2
410 LPRINT " ";I;
420 NEXT I
```

```

430 LPRINT CHR$(27);"%0"
440 LPRINT CHR$(27);"S0";
450 LPRINT CHR$(9);"MILLIONS OF DOLLARS"
460 LPRINT CHR$(27);"T"
470 END

```

```

      U.S. EXPORTS
AUTOS      OOOOOOOOOOOOOOOOOOOOOOOOOO
CHEMICALS  AAAAAAAAAAAAAAAAAAAAAAAAAA
GUNS       TTTT
          +-----+-----+-----+-----+
                2     4     6     8
          MILLIONS OF DOLLARS

```

## DEFINING PROPORTIONAL CHARACTERS

Defining proportional characters uses the same process as above, except that we add additional information. Being able to specify the width of the character allows you to specify the precise area inside the grid that the character will occupy, so that narrow characters will look attractive next to wide ones.

The additional information is carried in the attribute byte, *m0*. The first bit carries the descender data, the next three bits specify the starting column (acceptable values are 0 to 7), and the last four bits specify the last print column, including space when desired. Acceptable values are from 4 and 11. The minimum character width is five dots, anywhere within the range.

## DESIGNING YOUR OWN NLQ CHARACTERS

As you have probably noticed, NLQ characters are printed by two passes of the print head. Half of the character is printed on the first pass, and the remainder on the second pass. The paper is rolled up half a dot height in between passes to let the print head print dots on the second pass that overlap the previous dots, in order to fill in the spaces and produce denser characters. Additionally, the print head speed is halved, and the dots are printed at double the density of draft characters. For this

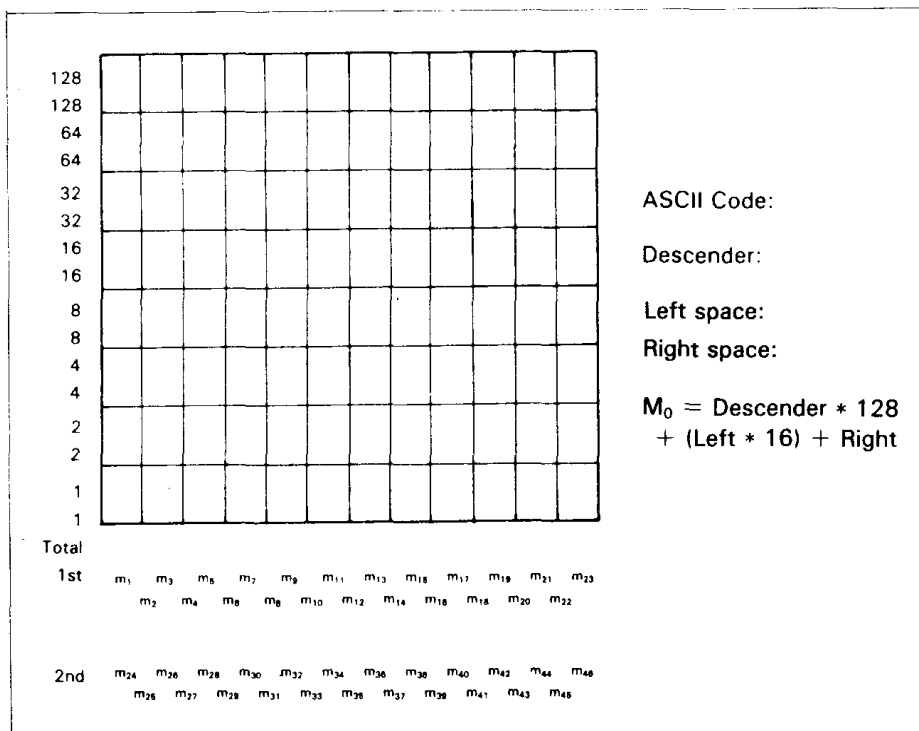


reason, NLQ characters can contain up to 23 dots in the horizontal direction.

Fundamentally, the process to define and print downloaded NLQ characters is the same as for draft characters, except that you must supply about four times as much character data, and you must design the character with the two passes of the print head in mind. There are small differences in the way the attribute information is processed also.

In the draft quality mode the attribute byte carries the descender data, and specifies the start and end printing columns. In the NLQ mode, the first bit also carries the descender data as with the draft characters, but the next three bits describe the character's left space, and the last four bits describe the right space. Appropriate allocation of data in these seven bits lets you place the character where you like within the grid, with the restriction that the character must be at least 9 dots wide.

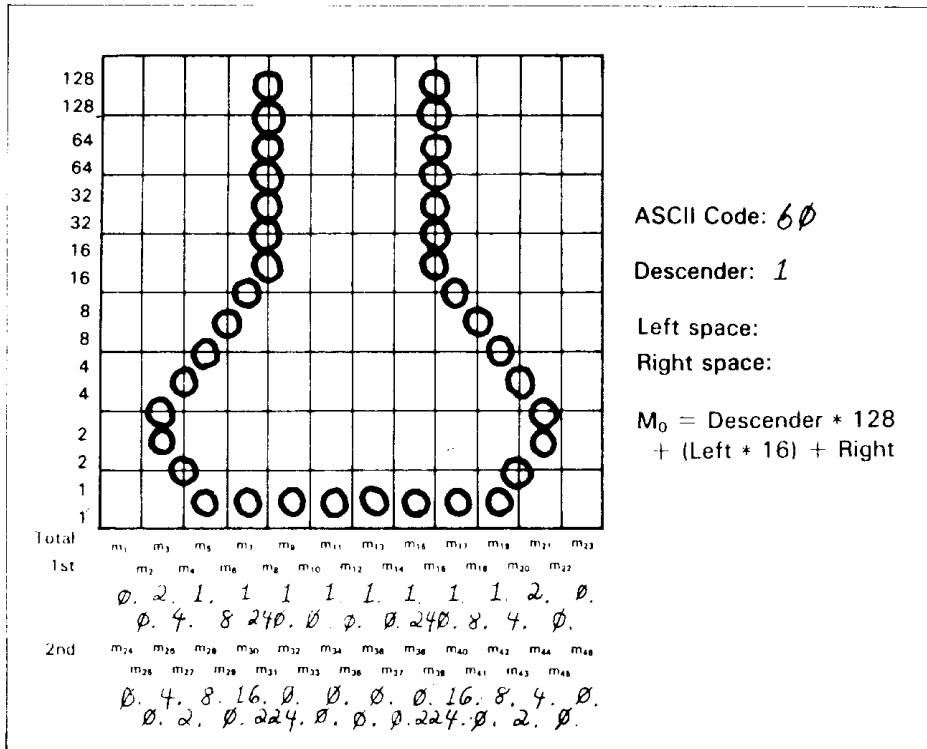
Use the grid in Figure 7-6 to help plot the data. Due to the two-pass process, NLQ characters can contain up to 16 dots vertically. *m1* to *m23* are the data for the first pass, and *m24* to *m46* are the data for the second pass.



**Figure 7-6.** Use this grid (or one similar to it) to define your own NLQ characters.

To make the character data easier to calculate, put the first pass dots inside the boxes on the grid when you are designing your characters, and the second pass dots on the lines. Remember that adjacent dots may not overlap on the same pass; in other words, if one dot is in a box, its adjacent dot on the same pass may not be on a line. Therefore, to make smooth characters, put the dots needed to overlap any spaces in a character in the appropriate places in the second pass grid.

If we replot our flask for NLQ, the grid data will look like Figure 7-7.



**Figure 7-7.** Add the values of the dots in the boxes first, and then add the values on the lines.

The defining process is the same as for draft characters, except that you must select NLQ characters by using <ESC> "x" 1 first to select the NLQ mode, and you must define 46 data (m1 to m46). If you wish to print your NLQ characters with the standard character set, the remarks regarding the simultaneous use of standard and download characters in the draft character section apply equally to NLQ characters.

To demonstrate how to use the NLQ download characters, try this program.

```
10 LPRINT CHR$(27);"x1";
20 LPRINT CHR$(27);":":CHR$(0);CHR$(0);CHR$(0);
30 LPRINT CHR$(27);"&":CHR$(0);CHR$(60);CHR$(62);
40 FOR N=60 TO 62
50 FOR M=0 TO 46
60 READ MM
70 LPRINT CHR$(MM);
80 NEXT M
90 NEXT N
100 LPRINT
110 DATA 128, 0, 0, 2, 4, 1, 8, 1,240, 1,
    0, 1
120 DATA 0, 1, 0, 1,240, 1, 8, 1, 4, 2,
    0, 0
130 DATA 0, 0, 4, 2, 8, 0, 16,224, 0, 0,
    0, 0
140 DATA 0, 0, 0,224, 16, 0, 8, 2, 4, 0,
    0
150 DATA 128, 14, 16, 38, 1, 70, 1, 70, 0,126,
    0, 0
160 DATA 70, 0, 38, 0, 22, 9, 6, 9, 6, 8,
    6, 0
170 DATA 28, 32, 14, 64, 14, 0, 14, 0,124, 0,
    0, 12
180 DATA 64, 12, 32, 14, 16, 14, 0, 14, 0, 12,
    0
190 DATA 128, 0, 24, 7, 56, 1, 56, 7, 8, 2,
    8, 6
200 DATA 8, 2, 8, 4, 8, 0, 8, 32, 8, 0,
    24, 0
210 DATA 32, 16, 14, 48, 14, 48, 14, 32, 0, 32,
    0, 40
220 DATA 0, 36, 0, 40, 0, 32, 0, 32, 0, 48,
    0
230 LPRINT CHR$(27);"D";CHR$(11);CHR$(0);
240 LPRINT CHR$(27);"h";CHR$(1);
250 LPRINT " U.S. EXPORTS"
260 LPRINT CHR$(27);"h";CHR$(0);
270 LPRINT CHR$(27);"%1";
280 LPRINT "AUTOS";CHR$(9);
290 FOR I=.4 TO 9.3 STEP .4
300 LPRINT CHR$(61);
```

```

310 NEXT I
320 LPRINT
330 LPRINT "CHEMICALS";CHR$(9);
340 FOR I=.4 TO 8.7 STEP .4
350 LPRINT CHR$(60);
360 NEXT I
370 LPRINT
380 LPRINT "GUNS";CHR$(9);
390 FOR I=.4 TO 1.4 STEP .4
400 LPRINT CHR$(62);
410 NEXT I
420 LPRINT
430 LPRINT CHR$(9);"+--";
440 SCALE$="--+--"
450 FOR I=2 TO 8 STEP 2
460 LPRINT SCALE$;
470 NEXT I
480 LPRINT "--+"
490 LPRINT CHR$(9);" ";
500 FOR I=2 TO 8 STEP 2
510 LPRINT " ";I;
520 NEXT I
530 LPRINT CHR$(27);"S0"
540 LPRINT CHR$(9);"MILLIONS OF DOLLARS"
550 LPRINT CHR$(27);"T"
560 LPRINT CHR$(27);"0"
570 END

```

```

      U . S . EXPORTS
AUTOS      @@@@@@@@@@@@@@@@@@@@@@@@@@@@@@@@@@@@@@@@@
CHEMICALS  ^^^^^^^^^^^^^^^^^^^^^^^^^^^^^^^^^^^^^^^^^
GUNS       ###
          +-----+-----+-----+-----+
              2       4       6       8
          MILLIONS OF DOLLARS

```

### USER-DESIGNED DOT GRAPHICS

Designing and printing graphics is similar to the procedures for characters, except that the printed width can range from one to 3264 dots. Selection of the appropriate line spacing will allow rows of dots to link seamlessly, and in this way you may design and print a whole page of data. In the dot graphics mode, you directly address all dot positions on the page if desired. The graphics mode can print as many as 240 dots per inch compared

with the standard resolution of 60 dots per inch (dpi).

The command to print normal density (60 dpi horizontally, 72 dpi vertically) uses this format:

⟨ESC⟩ “\*” CHR\$(0) *n1 n2 m1 m2* .....

⟨ESC⟩ “\*” specifies the graphics mode, the CHR\$(0) specifies normal density. Other densities are described later. Any number of graphics data may follow; the *n1* and *n2* specify the number of bytes.

To figure the value of *n1* and *n2*, you need to work out how wide your image will be. Because you are limited to the largest number that can be sent in one byte (255), the formula to work out *n1* and *n2* is:

if the number of columns is *X*,  
then  $n1 = X \text{ MOD } 256$ , and  $n2 = \text{INT}(X/256)$

Table 7-1 may make the calculation easier.

**Table 7-1**  
**Calculating *n1* and *n2*.**

If the number of columns, <i>x</i> , ranges from:	Then <i>n1</i> is:	and <i>n2</i> is:
1 to 255	<i>x</i>	0
256 to 511	<i>x</i> - 256	1
512 to 767	<i>x</i> - 512	2
768 to 1023	<i>x</i> - 768	3
1024 to 1279	<i>x</i> - 1024	4
1280 to 1535	<i>x</i> - 1280	5
1536 to 1791	<i>x</i> - 1536	6
1792 to 2047	<i>x</i> - 1792	7
2048 to 2303	<i>x</i> - 2048	8
2304 to 2559	<i>x</i> - 2304	9
2560 to 2815	<i>x</i> - 2560	10
2816 to 3071	<i>x</i> - 2816	11
3072 to 3264	<i>x</i> - 3072	12

*m1*, *m2* and so on are specified as before, that is, any desired combination of pins will be fired by just one number. Because the top eight pins are used in the dot graphics mode, numbers between 0 and 255 (in other words, one byte) will fire a unique combination of pins to produce any pattern of dots. Thus *m1*, *m2* and so on are the data bytes of the command.

To plot large graphics, use graph paper and draw a line every

eight rows. Draw your graphics shape, and then calculate the values of each vertical column of eight dots; each value becomes one data byte. When drawing large shapes, the data byte CHR\$(255) (all pins firing, or a solid block of dots) is common.

A line spacing of 8/72 inch (using the <ESC> "A" CHR\$(*n*), where *n*=8), will ensure that successive rows of dots will join perfectly.

## HIGHER RESOLUTION GRAPHICS

There are seven graphics modes you can use; they are summarized in Table 7-2.

**Table 7-2**

Function	Control code
Normal density (60 dots/inch)	<ESC>"*"CHR\$(0) <i>n1 n2 m1 m2 ...</i>
Double density (120 dots/inch)	<ESC>"*"CHR\$(1) <i>n1 n2 m1 m2 ...</i>
Double density/double speed	<ESC>"*"CHR\$(2) <i>n1 n2 m1 m2 ...</i>
Quadruple density (240 dots/inch)	<ESC>"*"CHR\$(3) <i>n1 n2 m1 m2 ...</i>
CRT graphics (80 dots/inch)	<ESC>"*"CHR\$(4) <i>n1 n2 m1 m2 ...</i>
Plotter graphics (72 dots/inch)	<ESC>"*"CHR\$(5) <i>n1 n2 m1 m2 ...</i>
CRT graphics type II (90 dots/inch)	<ESC>"*"CHR\$(6) <i>n1 n2 m1 m2 ...</i>

You will notice that the higher the density of the graphic mode, the more points you will need to plot. Higher density modes also take longer to print. The double density double speed mode ignores every second column of dots to give you a quick printout for debugging purposes; you can then change to true double density graphics for the final printout.

If your software cannot access the <ESC> "\*" command, there are individual letter escape commands for four of the modes. See Table 7-3.

**Table 7-3**  
Alternative graphics commands

Density	Single command	Individual command
Noraml	$\langle \text{ESC} \rangle "*" \text{CHR}\$(0) n1 n2$ $m1 m2 \dots$	$\langle \text{ESC} \rangle "K" n1 n2 m1 m2 \dots$
Double	$\langle \text{ESC} \rangle "*" \text{CHR}\$(1) n1 n2$ $m1 m2 \dots$	$\langle \text{ESC} \rangle "L" n1 n2 m1 m2 \dots$
Double with double-speed	$\langle \text{ESC} \rangle "*" \text{CHR}\$(2) n1 n2$ $m1 m2 \dots$	$\langle \text{ESC} \rangle "Y" n1 n2 m1 m2 \dots$
Quadruple	$\langle \text{ESC} \rangle "*" \text{CHR}\$(3) n1 n2$ $m1 m2 \dots$	$\langle \text{ESC} \rangle "Z" n1 n2 m1 m2 \dots$
CRT	$\langle \text{ESC} \rangle "*" \text{CHR}\$(4) n1 n2$ $m1 m2 \dots$	none
Plotter	$\langle \text{ESC} \rangle "*" \text{CHR}\$(5) n1 n2$ $m1 m2 \dots$	none
CRT type II	$\langle \text{ESC} \rangle "*" \text{CHR}\$(6) n1 n2$ $m1 m2 \dots$	none

## MORE GRAPHICS PROGRAMMING TIPS

At the end of this chapter, we'll discuss two modes that the printer offers to help you solve potential graphics problems. A redefining code allows you to change the density for graphics programs that use one of the four alternate codes. The 9-pin graphics mode allows you to use all nine pins on each line and thus speed up screen dumps.

**Table 7-4**  
More graphics commands

Function	Control code
Redefine the graphics mode	$\langle \text{ESC} \rangle "?" n0 n1$
9-pin graphics	$\langle \text{ESC} \rangle " \sim " n0 n1 n2 m1 m2 \dots$

### ■ Redefining alternate graphics codes

Your printer provides a command to redefine one of the alternate graphics modes — K, L, Y, or Z — so that it represents any other of the seven graphics modes. The command is  $\langle \text{ESC} \rangle "?" n0 n1$ , where  $n0$  is one of the four letters, "K", "L", "Y", or "Z", and  $n1$  is one of the numbers used with the  $\langle \text{ESC} \rangle "*" \text{CHR}\$(n)$  command, 0 to 6. There are several instances in which you may use this sequence.

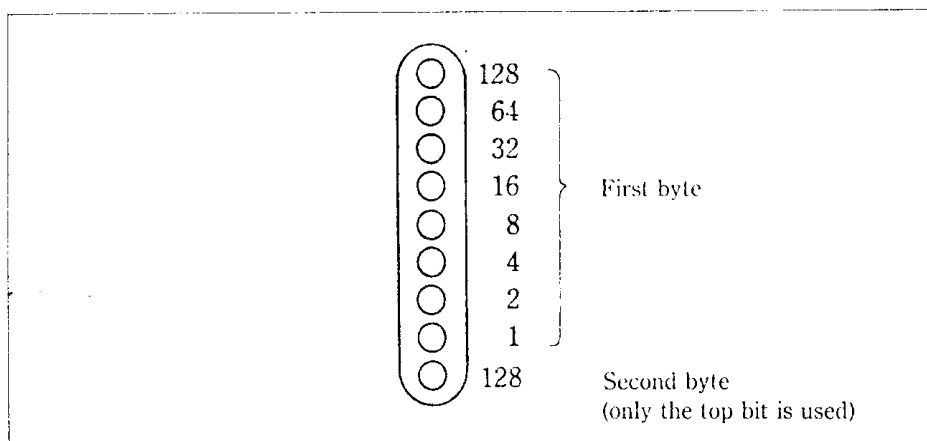
The first occurs if you have written a program to be printed in one graphics mode and now want to print it in another. If you have used concatenation to store your graphics command in one short character string, that will not be difficult. You can simply change the mode number or alternate code in the definition of the character string.

A second time you can make good use of the redefining code occurs when you want to change a program in which you have not concatenated the graphics codes. Using the  $\langle \text{ESC} \rangle$  “?” sequence allows you to change every instance of your graphics command by entering only one line.

### ■ 9-pin graphics mode

In the early part of this chapter, we said that the bottom pin of the print head is not normally used in the graphics modes. That's because most computers communicate with parallel-type peripheral devices using eight data lines. When the peripheral is a printer, each data line corresponds to one pin on the print head. Thus each byte sent will fire up to eight pins.

But the printer has 9 pins available. So how do you fire the ninth pin with only 8 data lines? In fact, do you really want to bother with just one extra pin? Well, for such graphics-intensive applications as screen dumps, printing 9 pins at a time can speed up the process considerably. For this purpose, your printer has a special 9-pin graphics mode (it won't, however, work with 7-bit interface systems). In this mode the printer takes 2 bytes to fire all 9 pins as shown in Figure 7-8.



**Figure 7-8.** The printer needs 2 bytes to fire all 9 pins in the 9-pin graphics mode.



In addition, you can select the print density by the value of  $n0$ . When  $n0$  is 0 the normal density is selected, and when  $n0$  is 1 the double density is selected.

Since computers are faster than printers, there is no significant time loss in printing a single line of graphics with 9 pins. You get 9 dots per line in about the same time as you get 8 dots in the other graphics modes.

all-guides.com

## MEMO

---

---

# CHAPTER 8

## CARING

### FOR YOUR PRINTER

---

---

**Subjects covered in Chapter 8 include—**

- **Cleaning the printer**
- **Changing the ribbon**
- **Replacing the print head**

Dust and heat will make any mechanism wear more quickly. The best maintenance is *preventive*, so the first step in any maintenance program is correct location of the printer. This is covered in greater detail in Chapter 1, but in general a normal office environment is best for both the computer and the printer.

#### **CLEANING THE PRINTER**

Cleaning the printer regularly will prolong its service life. Use a damp cloth on the exterior every week or so. For stubborn dirt, you may moisten the cloth with alcohol or water containing a mild detergent, but be careful not to spill any liquid into the interior of the printer or onto the print mechanism.

Use a soft brush to remove paper dust and lint from the interior. A small vacuum cleaner can also make this task easier — but be very careful not to bend or injure any electronic parts or wiring. The printer contains delicate electronic parts, so only clean those places where you have easy access.

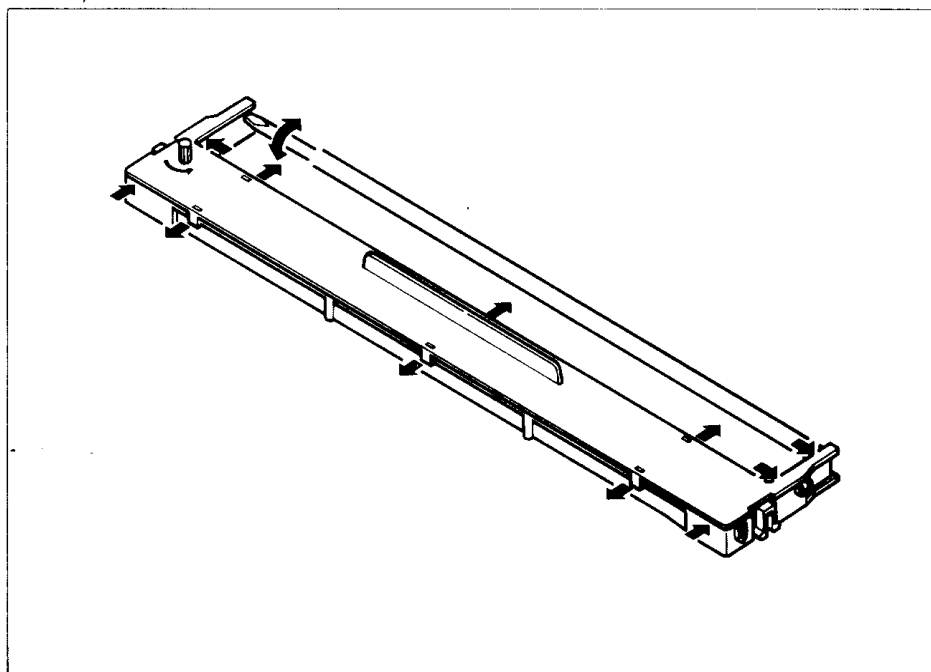
#### **REPLACING THE RIBBON**

This printer uses an endless-type ribbon cartridge, meaning that the ribbon is recycled automatically. In time, however, when the print becomes too faint to read clearly, you will need to change either the whole cartridge or the ribbon inside it.

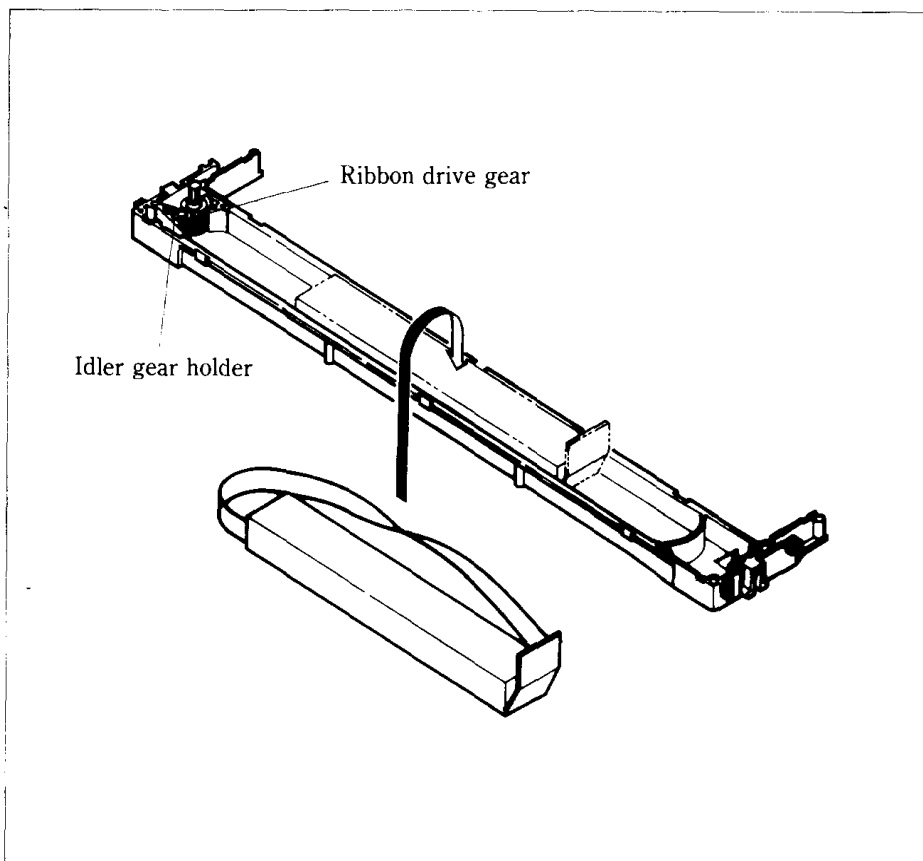
Changing the whole cartridge is the simplest method, and because you don't need to touch the ribbon itself, it is the cleanest way too. To remove the old cartridge, remove the printer cover, grasp the ribbon cartridge with both hands, and pull straight up gently until the holder springs release. To fit the new cartridge, refer to Chapter 1, Installing the ribbon cartridge.

A more economical method is to only replace the ribbon itself. First, obtain the correct type of replacement sub-cassette from your dealer. Use the following procedure to change the ribbon.

1. Place the cartridge on a flat surface, and use a flat-bladed screwdriver to unhook the tabs holding the two sections of the cartridge together. See Figure 8-1.
2. After opening the cartridge, take a moment to notice how the ribbon is threaded. Then press a finger against the idler gear holder (it is held in position by spring pressure), and make enough space to remove the ribbon from between the two gears. See Figure 8-2.
3. Clean the inside of the cartridge, especially around the vicinity of the two gears.

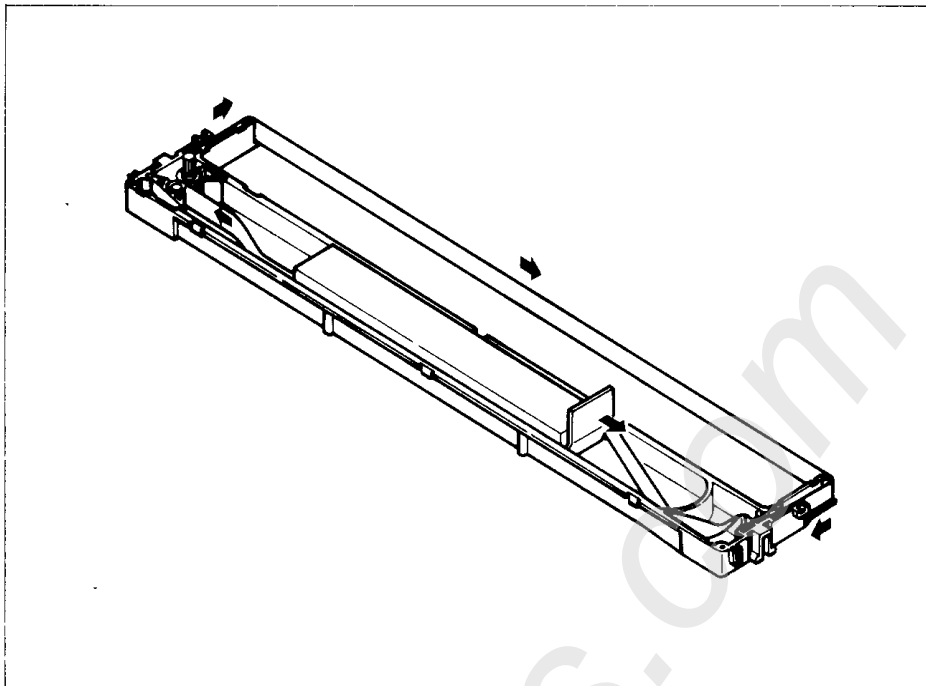


**Figure 8-1.** Unhook tabs to pry open the cartridge.



**Figure 8-2.** Replace the ribbon sub-cassette.

4. Take the new ribbon and holder out of the wrapper, remove the adhesive tape on the joint on the holder, and place it into the cassette as shown in Figure 8-2.
5. Pull sufficient ribbon out of the holder, and thread it as shown in Figure 8-3. Be careful that the half-twist in the ribbon is positioned in the right-hand section of the ribbon cartridge, between the two guide posts. Make sure that no twists occur anywhere else.
6. Again press on the idler gear holder and thread the ribbon between both gears.
7. Remove the top and bottom of the ribbon holder, and replace the cartridge top cover. Snap all tabs back into place.
8. When you've completed the installation, remount the cartridge to the printer. Notice that you should replace the whole cartridge after replacing the ribbon five times.



**Figure 8-3.** Make sure that the ribbon is not twisted when you thread it through its path.

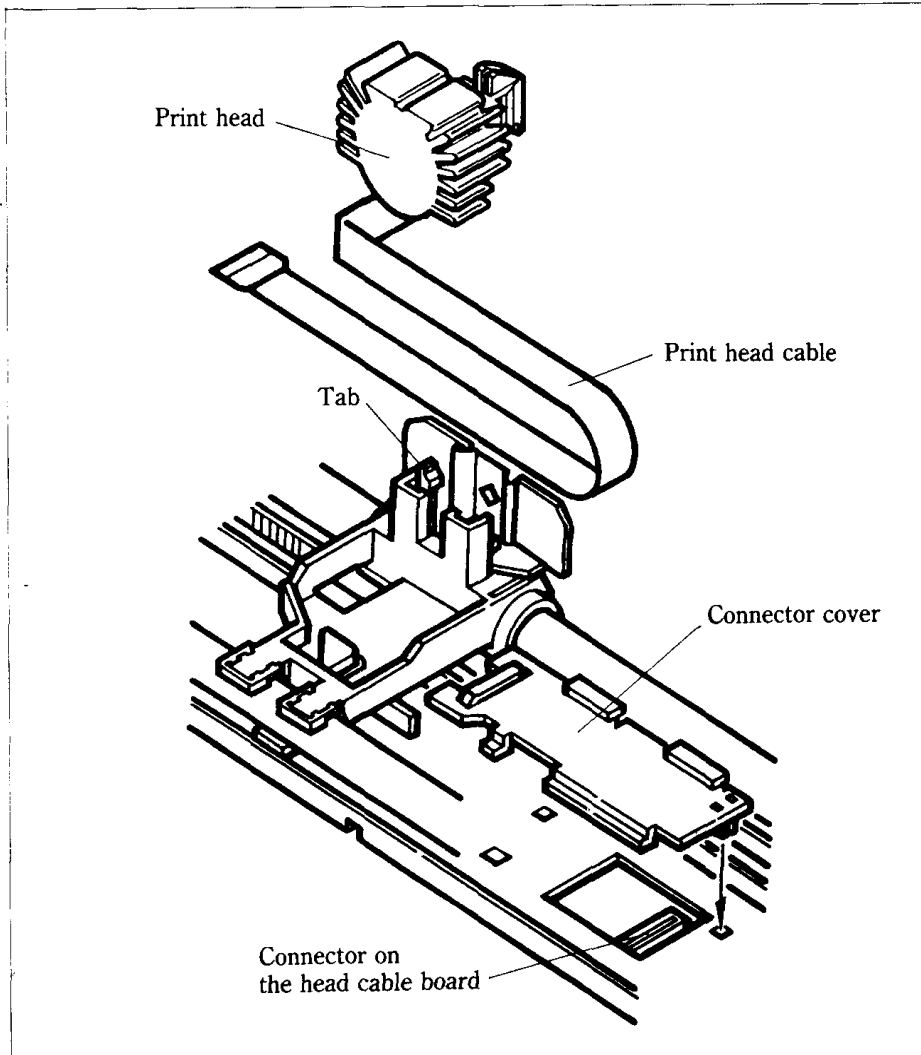
## REPLACING THE PRINT HEAD

The dot matrix print head has an extremely long life, around 100,000,000 characters, or years of normal use. However, when printing is too light even after replacing the ribbon, you'll know that the print head has reached the end of its service life.

Turn off the power, unplug the power cord, and use the following procedure to replace the print head.

**Warning:** The print head becomes hot during operation. If you have been using the printer, let it stand for a while so that the print head can cool off.

1. Remove the printer cover and the ribbon cartridge.
2. Remove the print head left along the carriage, until you can see the connector cover. Remove the cover from the printer frame; for details, see Figure 8-4. Unplug the print head cable from the head cable board.



**Figure 8-4.** Replacement of the print head.

3. Hold back the tab that locks the print head into place, and remove the print head.
4. Making sure that the new print head is facing the correct direction, carefully plug the cable into the connector on the head cable board. Make sure that this connection is secure, and that the cable is inserted far enough into the connector.
5. Replace the connector cover, and feed the cable under the support tab on the top of the cover.
6. Fit the new print head into its support, while holding the tab back. Make sure that the print head is inserted into its guides as far as it can go, and that the tab locks the print head into place.

**MEMO**



---

---

## APPENDIX A

---

---

# DIP SWITCH SETTINGS

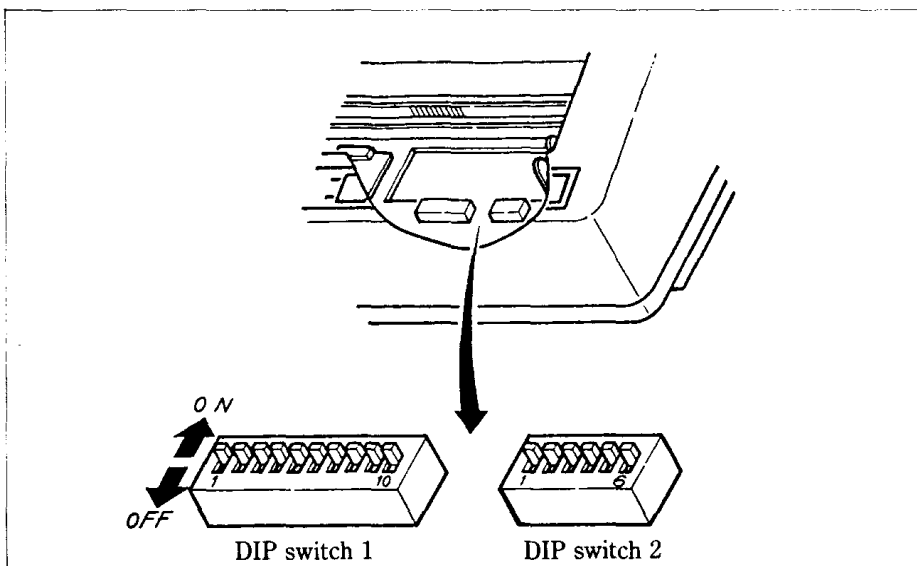
---

---

The DIP (Dual In-line Package) switches control many of the functions of the printer. A DIP switch contains a number of small switches, and in this printer, one DIP switch has 10 individual switches and the another has 6 individual switches.

Both DIP switches are easily accessible from the top of the printer. Remove the ribbon cartridge, and you will see the two DIP switches underneath a sheet of protective plastic film, which you fold back for access. DIP switch 1 is the one on the right as you look at the printer from the front. The individual switches of DIP switch 1 are named from 1-1 to 1-10; similarly, the switches of DIP switch 2 go from 2-1 to 2-6.

To change a setting, turn the power OFF, and use a ball-point pen or similar to move any of the small white switches to the front or back of the printer. The "on" position for all switches is towards the back of the printer, and "off" is to the front. Figure A-1 shows the location of the printer's DIP switches.



**Figure A-1.** The DIP switches are located under the printer cover.

**CAUTION:**

Never change the setting of any of the DIP switches when the power is on. The printer only reads the DIP switch settings at the moment the power is turned on. Turn off power to both the computer and the printer when changing settings, and turn on again to use the new settings.

Table A-1 shows a summary of DIP switch functions.

**Table A-1**  
**DIP switch settings**

Switch	ON	OFF
<b>Switch 1</b>		
1-1	11-inch page length	12-inch page length
1-2	Draft characters	NLQ characters
1-3	Print "normal zero"	Print "slash zero"
1-4	No bottom margin	Set bottom margin to 1 inch
1-5	Paper-out detected	Paper-out not detected
1-6	Set SELECT IN signal to LOW	Not fixed
1-7	Character set #1	Character set #2
1-8	LF from host	Auto LF with CR
1-9	(Not used)	
1-10	(Not used)	
<b>Switch 2</b>		
2-1	Ignore download characters	Enable download characters
2-2	International character set selection – see Table A-2.	
2-3		
2-4		
2-5	Set standard mode	Set IBM mode
2-6	(Not used)	

**SWITCH FUNCTIONS****Switch    Function**

- 1-1    This switch sets the default page length. If this switch is on the default page length is 11 inches. If this switch is off the default page length is 12 inches. This switch is set on at the factory.

- 1-2 This switch selects the default character style. If this switch is on the default character style is normal draft characters. If this switch is off the default character style is Near Letter Quality (NLQ) characters. This switch is set on at the factory.
- 1-3 This switch selects the print style of zeroes. If this switch is on, normal zeroes are printed. If this switch is off, slashed zeroes are printed. This switch is set on at the factory.
- 1-4 This switch determines the default bottom margin. When this switch is on, the bottom margin is not set at power-on. When this switch is off, the bottom margin is automatically set to 1 inch. This switch is set on at the factory.
- 1-5 This switch disables the paper-out detector. If this switch is on, the printer will signal the computer when it runs out of paper and printing will stop. If this switch is off, the printer will ignore the paper-out detector and will continue printing. This switch is set on at the factory.
- 1-6 This switch controls the status of SELECT IN signal of the parallel interface. If this switch is on, this signal is held to LOW. If this switch is off, the signal goes HIGH when the printer cannot get data. This switch is set on at the factory.
- 1-7 This switch selects the default character set. If this switch is on, the default character set is character set #1. If this switch is off, the default character set is character set #2. If switch 2-5 is on, this switch have no effect. This switch is set on at the factory.
- 1-8 When this switch is on, the computer must send a line feed command each time to advance the paper. When this switch is off, the printer will automatically advance the paper one line every time it receives a carriage return. (For example, most BASIC's send a line feed with every carriage return; in this case, this switch should be on.) This switch is set on at the factory.
- 2-1 This switch controls the RAM. When this switch is on, the download character definitions are ignored and the RAM is used as a print buffer. When this switch is off, the download character definitions are

enable and the print buffer is set to a one line buffer. This switch is set on at the factory.

2-2~2-4 These switches determine the default international character set, as shown in Table A-2. These switches are all set on at the factory.

**Table A-2**  
**International character sets**

Switch	U.S.A.	France	Germany	England	Denmark	Sweden	Italy	Spain
2-2	ON	OFF	ON	OFF	ON	OFF	ON	OFF
2-3	ON	ON	OFF	OFF	ON	ON	OFF	OFF
2-4	ON	ON	ON	ON	OFF	OFF	OFF	OFF

2-5 This switch selects the active control codes. Turn this switch on to use the "Standard" mode, which emulates the Epson FX-85 printer. Turn this switch off to use the "IBM" mode, which emulates the IBM Graphics printer. This switch is set on at the factory.

---



---

# APPENDIX B

## ASCII CODES AND CONVERSION CHART

---



---

Standard ASCII Codes			Control	Character set	
Decimal	Hex.	Binary	Character	Set1	Set2
0	00	0000 0000	Ctrl-@		
1	01	0000 0001	Ctrl-A		
2	02	0000 0010	Ctrl-B		
3	03	0000 0011	Ctrl-C		♥ ♥ ♥
4	04	0000 0100	Ctrl-D		♦ ♦ ♦
5	05	0000 0101	Ctrl-E		♣ ♣ ♣
6	06	0000 0110	Ctrl-F		♠ ♠ ♠
7	07	0000 0111	Ctrl-G	BEL	BEL
8	08	0000 1000	Ctrl-H	BS	BS
9	09	0000 1001	Ctrl-I	HT	HT
10	0A	0000 1010	Ctrl-J	LF	LF
11	0B	0000 1011	Ctrl-K	VT	VT
12	0C	0000 1100	Ctrl-L	FF	FF
13	0D	0000 1101	Ctrl-M	CR	CR
14	0E	0000 1110	Ctrl-N	SO	SO
15	0F	0000 1111	Ctrl-O	SI	SI
16	10	0001 0000	Ctrl-P		
17	11	0001 0001	Ctrl-Q	DC1	DC1
18	12	0001 0010	Ctrl-R	DC2	DC2
19	13	0001 0011	Ctrl-S	DC3	DC3
20	14	0001 0100	Ctrl-T	DC4	DC4
21	15	0001 0101	Ctrl-U		§ § §
22	16	0001 0110	Ctrl-V		
23	17	0001 0111	Ctrl-W		
24	18	0001 1000	Ctrl-X	CAN	CAN
25	19	0001 1001	Ctrl-Y	EM	EM
26	1A	0001 1010	Ctrl-Z		
27	1B	0001 1011		ESC	ESC
28	1C	0001 1100			
29	1D	0001 1101			
30	1E	0001 1110			
31	1F	0001 1111			
32	20	0010 0000		Space	Space

Standard ASCII Codes			Character set					
Decimal	Hexadecimal	Binary	Set1			Set2		
33	21	0010 0001	!	!	!	!	!	!
34	22	0010 0010	"	"	"	"	"	"
35	23	0010 0011	#	#	#	#	#	#
36	24	0010 0100	\$	\$	\$	\$	\$	\$
37	25	0010 0101	%	%	%	%	%	%
38	26	0010 0110	&	&	&	&	&	&
39	27	0010 0111	'	'	'	'	'	'
40	28	0010 1000	(	(	(	(	(	(
41	29	0010 1001	)	)	)	)	)	)
42	2A	0010 1010	*	*	*	*	*	*
43	2B	0010 1011	+	+	+	+	+	+
44	2C	0010 1100	,	,	,	,	,	,
45	2D	0010 1101	-	-	-	-	-	-
46	2E	0010 1110	.	.	.	.	.	.
47	2F	0010 1111	/	/	/	/	/	/
48	30	0011 0000	0	0	0	0	0	0
49	31	0011 0001	1	1	1	1	1	1
50	32	0011 0010	2	2	2	2	2	2
51	33	0011 0011	3	3	3	3	3	3
52	34	0011 0100	4	4	4	4	4	4
53	35	0011 0101	5	5	5	5	5	5
54	36	0011 0110	6	6	6	6	6	6
55	37	0011 0111	7	7	7	7	7	7
56	38	0011 1000	8	8	8	8	8	8
57	39	0011 1001	9	9	9	9	9	9
58	3A	0011 1010	:	:	:	:	:	:
59	3B	0011 1011	;	;	;	;	;	;
60	3C	0011 1100	<	<	<	<	<	<
61	3D	0011 1101	=	=	=	=	=	=
62	3E	0011 1110	>	>	>	>	>	>
63	3F	0011 1111	?	?	?	?	?	?
64	40	0100 0000	@	@	@	@	@	@
65	41	0100 0001	A	A	A	A	A	A
66	42	0100 0010	B	B	B	B	B	B
67	43	0100 0011	C	C	C	C	C	C
68	44	0100 0100	D	D	D	D	D	D
69	45	0100 0101	E	E	E	E	E	E
70	46	0100 0110	F	F	F	F	F	F
71	47	0100 0111	G	G	G	G	G	G
72	48	0100 1000	H	H	H	H	H	H
73	49	0100 1001	I	I	I	I	I	I
74	4A	0100 1010	J	J	J	J	J	J
75	4B	0100 1011	K	K	K	K	K	K
76	4C	0100 1100	L	L	L	L	L	L

Standard ASCII Codes			Character set		
Decimal	Hexadecimal	Binary	Set1		Set2
77	4D	0100 1101	M	M M	M M M
78	4E	0100 1110	N	N N	N N N
79	4F	0100 1111	O	O O	O O O
80	50	0101 0000	P	P P	P P P
81	51	0101 0001	Q	Q Q	Q Q Q
82	52	0101 0010	R	R R	R R R
83	53	0101 0011	S	S S	S S S
84	54	0101 0100	T	T T	T T T
85	55	0101 0101	U	U U	U U U
86	56	0101 0110	V	V V	V V V
87	57	0101 0111	W	W W	W W W
88	58	0101 1000	X	X X	X X X
89	59	0101 1001	Y	Y Y	Y Y Y
90	5A	0101 1010	Z	Z Z	Z Z Z
91	5B	0101 1011	[	[ [	[ [ [
92	5C	0101 1100	\	\ \	\ \ \
93	5D	0101 1101	]	] ]	] ] ]
94	5E	0101 1110	^	^ ^	^ ^ ^
95	5F	0101 1111	_	_ _	_ _ _
96	60	0110 0000			
97	61	0110 0001	a	a a	a a a
98	62	0110 0010	b	b b	b b b
99	63	0110 0011	c	c c	c c c
100	64	0110 0100	d	d d	d d d
101	65	0110 0101	e	e e	e e e
102	66	0110 0110	f	f f	f f f
103	67	0110 0111	g	g g	g g g
104	68	0110 1000	h	h h	h h h
105	69	0110 1001	i	i i	i i i
106	6A	0110 1010	j	j j	j j j
107	6B	0110 1011	k	k k	k k k
108	6C	0110 1100	l	l l	l l l
109	6D	0110 1101	m	m m	m m m
110	6E	0110 1110	n	n n	n n n
111	6F	0110 1111	o	o o	o o o
112	70	0111 0000	p	p p	p p p
113	71	0111 0001	q	q q	q q q
114	72	0111 0010	r	r r	r r r
115	73	0111 0011	s	s s	s s s
116	74	0111 0100	t	t t	t t t
117	75	0111 0101	u	u u	u u u
118	76	0111 0110	v	v v	v v v
119	77	0111 0111	w	w w	w w w
120	78	0111 1000	x	x x	x x x

Standard ASCII Codes			Character set		
Decimal	Hexadecimal	Binary	Set1	Set2	
121	79	0111 1001	Y	Y	Y
122	7A	0111 1010	Z	Z	Z
123	7B	0111 1011	{	{	{
124	7C	0111 1100			
125	7D	0111 1101	}	}	}
126	7E	0111 1110	~	~	~
127	7F	0111 1111	DEL	DEL	
128	80	1000 0000		Ç	Ç
129	81	1000 0001		ü	ü
130	82	1000 0010		é	é
131	83	1000 0011		â	â
132	84	1000 0100		ä	ä
133	85	1000 0101		à	à
134	86	1000 0110		ã	ã
135	87	1000 0111	BEL	ç	ç
136	88	1000 1000	BS	è	è
137	89	1000 1001	HT	ë	ë
138	8A	1000 1010	LF	è	è
139	8B	1000 1011	VT	ï	ï
140	8C	1000 1100	FF	î	î
141	8D	1000 1101	CR	ì	ì
142	8E	1000 1110	SO	Ä	Ä
143	8F	1000 1111	SI	Å	Å
144	90	1001 0000		É	É
145	91	1001 0001	DC1	æ	æ
146	92	1001 0010	DC2	Æ	Æ
147	93	1001 0011	DC3	ô	ô
148	94	1001 0100	DC4	ö	ö
149	95	1001 0101		ò	ò
150	96	1001 0110		û	û
151	97	1001 0111		ù	ù
152	98	1001 1000	CAN	ÿ	ÿ
153	99	1001 1001	EM	ö	ö
154	9A	1001 1010		U	U
155	9B	1001 1011	ESC	ç	ç
156	9C	1001 1100		£	£
157	9D	1001 1101		¥	¥
158	9E	1001 1110		℞	℞
159	9F	1001 1111		f	f
160	A0	1010 0000	á	á	á
161	A1	1010 0001	í	í	í
162	A2	1010 0010	ó	ó	ó
163	A3	1010 0011	ú	ú	ú
164	A4	1010 0100	ñ	ñ	ñ



Standard ASCII Codes			Character set		
Decimal	Hexadecimal	Binary	Set1		Set2
165	A5	1010 0101	N	N	N
166	A6	1010 0110	a	a	a
167	A7	1010 0111	o	o	o
168	A8	1010 1000	z	z	z
169	A9	1010 1001	r	r	r
170	AA	1010 1010	r	r	r
171	AB	1010 1011	½	½	½
172	AC	1010 1100	¼	¼	¼
173	AD	1010 1101	;	;	;
174	AE	1010 1110	<<	<<	<<
175	AF	1010 1111	>>	>>	>>
176	B0	1011 0000	⋮	⋮	⋮
177	B1	1011 0001	⋮	⋮	⋮
178	B2	1011 0010	⋮	⋮	⋮
179	B3	1011 0011			
180	B4	1011 0100	+	+	+
181	B5	1011 0101	+	+	+
182	B6	1011 0110			
183	B7	1011 0111			
184	B8	1011 1000	7	7	7
185	B9	1011 1001			
186	BA	1011 1010			
187	BB	1011 1011			
188	BC	1011 1100			
189	BD	1011 1101			
190	BE	1011 1110			
191	BF	1011 1111	7	7	7
192	C0	1100 0000	L	L	L
193	C1	1100 0001	L	L	L
194	C2	1100 0010	T	T	T
195	C3	1100 0011	T	T	T
196	C4	1100 0100	-	-	-
197	C5	1100 0101	+	+	+
198	C6	1100 0110	+	+	+
199	C7	1100 0111			
200	C8	1100 1000			
201	C9	1100 1001			
202	CA	1100 1010			

Decimal	Standard ASCII Codes		Character set					
	Hexadecimal	Binary	Set1			Set2		
203	C B	1100 1011	ƒ	ƒ	ƒ	ƒ	ƒ	ƒ
204	C C	1100 1100	ƒ	ƒ	ƒ	ƒ	ƒ	ƒ
205	C D	1100 1101	=	=	=	=	=	=
206	C E	1100 1110	ƒ	ƒ	ƒ	ƒ	ƒ	ƒ
207	C F	1100 1111	±	±	±	±	±	±
208	D 0	1101 0000	ll	ll	ll	ll	ll	ll
209	D 1	1101 0001	ƒ	ƒ	ƒ	ƒ	ƒ	ƒ
210	D 2	1101 0010	ll	ll	ll	ll	ll	ll
211	D 3	1101 0011	ll	ll	ll	ll	ll	ll
212	D 4	1101 0100	l	l	l	l	l	l
213	D 5	1101 0101	F	F	F	F	F	F
214	D 6	1101 0110	ll	ll	ll	ll	ll	ll
215	D 7	1101 0111	ll	ll	ll	ll	ll	ll
216	D 8	1101 1000	ƒ	ƒ	ƒ	ƒ	ƒ	ƒ
217	D 9	1101 1001	J	J	J	J	J	J
218	D A	1101 1010	Γ	Γ	Γ	Γ	Γ	Γ
219	D B	1101 1011	■	■	■	■	■	■
220	D C	1101 1100	■	■	■	■	■	■
221	D D	1101 1101	■	■	■	■	■	■
222	D E	1101 1110	■	■	■	■	■	■
223	D F	1101 1111	■	■	■	■	■	■
224	E 0	1110 0000	α	α	α	α	α	α
225	E 1	1110 0001	β	β	β	β	β	β
226	E 2	1110 0010	Γ	Γ	Γ	Γ	Γ	Γ
227	E 3	1110 0011	π	π	π	π	π	π
228	E 4	1110 0100	Σ	Σ	Σ	Σ	Σ	Σ
229	E 5	1110 0101	σ	σ	σ	σ	σ	σ
230	E 6	1110 0110	μ	μ	μ	μ	μ	μ
231	E 7	1110 0111	τ	τ	τ	τ	τ	τ
232	E 8	1110 1000	Φ	Φ	Φ	Φ	Φ	Φ
233	E 9	1110 1001	Θ	Θ	Θ	Θ	Θ	Θ
234	E A	1110 1010	Ω	Ω	Ω	Ω	Ω	Ω
235	E B	1110 1011	δ	δ	δ	δ	δ	δ
236	E C	1110 1100	ω	ω	ω	ω	ω	ω
237	E D	1110 1101	Ø	Ø	Ø	Ø	Ø	Ø
238	E E	1110 1110	€	€	€	€	€	€
239	E F	1110 1111	∩	∩	∩	∩	∩	∩
240	F 0	1111 0000	≡	≡	≡	≡	≡	≡
241	F 1	1111 0001	±	±	±	±	±	±

Standard ASCII Codes			Character set					
Decimal	Hexadecimal	Binary	Set1			Set2		
242	F2	1111 0010	∫	∫	∫	∫	∫	∫
243	F3	1111 0011	≤	≤	≤	≤	≤	≤
244	F4	1111 0100	∫	∫	∫	∫	∫	∫
245	F5	1111 0101	∫	∫	∫	∫	∫	∫
246	F6	1111 0110	∫	∫	∫	∫	∫	∫
247	F7	1111 0111	∫	∫	∫	∫	∫	∫
248	F8	1111 1000	∫	∫	∫	∫	∫	∫
249	F9	1111 1001	∫	∫	∫	∫	∫	∫
250	FA	1111 1010	∫	∫	∫	∫	∫	∫
251	FB	1111 1011	∫	∫	∫	∫	∫	∫
252	FC	1111 1100	∫	∫	∫	∫	∫	∫
253	FD	1111 1101	∫	∫	∫	∫	∫	∫
254	FE	1111 1110	∫	∫	∫	∫	∫	∫
255	FF	1111 1111	∫	∫	∫	∫	∫	∫

**MEMO**

---



---

## APPENDIX C

# FUNCTION CODES

---



---

The purpose of this Appendix is to provide a quick reference for the various functions available on this printer. Codes are described in the following format.

<b>PURPOSE</b>	<b>Tells what the function code does.</b>
<b>CODE</b>	Control code mnemonic
(decimal ASCII)	ASCII decimal equivalent
(hex ASCII)	Hexadecimal equivalent
<b>REMARKS</b>	Briefly describes how the command is used.
<b>SEE</b>	Tells where any additional details of the command may be found.

Several commands require you to specify a value or values. In these cases, we have used an “*n*” or “*m*” to indicate a variable. You should insert the ASCII code for the proper value here.

### COMMANDS TO CONTROL PRINT STYLE

These commands are used to control the font style, the print pitch, and special effects.

#### ■ Font style controls

<b>PURPOSE</b>	<b>Selects italic characters.</b>
<b>CODE</b>	<ESC>    “4”
(decimal ASCII)	27        52
(hex ASCII)	1B        34
<b>REMARKS</b>	This command causes all subsequent characters to be printed in italics until italic printing is cancelled.
<b>SEE</b>	Chapter 4

<b>PURPOSE</b>	<b>Cancels italic characters.</b>		
<b>CODE</b>	<ESC>	"5"	
(decimal ASCII)	27	53	
(hex ASCII)	1B	35	
<b>REMARKS</b>	This command causes the printer to cancel italic printing and select the standard roman characters. This command is ignored when the "Italic Panel" mode is selected at power-on.		
<b>SEE</b>	Chapter 4		

<b>PURPOSE</b>	<b>Selects an international character set.</b>		
<b>CODE</b>	<ESC>	"R"	<i>n</i>
(decimal ASCII)	27	82	<i>n</i>
(hex ASCII)	1B	52	<i>n</i>
<b>REMARKS</b>	This command selects the international character set according to the value of <i>n</i> as shown in the table below:		

<i>n</i>	Character set	<i>n</i>	Character set
0	U.S.A.	6	Italy
1	France	7	Spain
2	Germany	8	Japan
3	England	9	Norway
4	Denmark I	10	Denmark II
5	Sweden		

You can select a specific international character set (except Japan, Norway, and Denmark type II), as a power-on default by adjusting the settings of DIP switches 2-2, 2-3, and 2-4.

<b>SEE</b>	Chapter 6
------------	-----------

**PURPOSE**                    **Selects character set #2.**

**CODE**                        <ESC>        "6"  
(decimal ASCII)                27            54  
(hex ASCII)                    1B            36

**REMARKS**                    This command selects character set #2 when the DIP switch 2-5 is set off. You can select character set #2 as the power-on default by turning DIP switch 1-7 off while the DIP switch 2-5 is set off.

**SEE**                         Chapter 6

**PURPOSE**                    **Selects character set #1.**

**CODE**                        <ESC>        "7"  
(decimal ASCII)                27            55  
(hex ASCII)                    1B            37

**REMARKS**                    This command cancels character set #2 and selects character set #1 when the DIP switch 2-5 is set off. You can select character set #1 as the power-on default by turning DIP switch 1-7 on while the DIP switch 2-5 is set off.

**SEE**                         Chapter 6

**PURPOSE**                      **Selects NLQ characters.**

<b>CODE</b>	<ESC>	“x”	1
(decimal ASCII)	27	120	1
(hex ASCII)	1B	78	01

**REMARKS**                      This command causes the printer to print near letter quality (NLQ) characters until the NLQ mode is cancelled. You can select NLQ characters as the power-on default by turning DIP switch 1-2 off. This command is ignored when the “Print Quality Panel” mode is selected at power-on.

**NOTE:** The character “1” (decimal code 49, hexadecimal code 31) can be used instead of ASCII 1.

**SEE**                              Chapter 4

**PURPOSE**                       **Cancels NLQ characters.**

<b>CODE</b>	<ESC>	“x”	0
(decimal ASCII)	27	120	0
(hex ASCII)	1B	78	00

**REMARKS**                      This command cancels NLQ printing and returns the printer to the draft mode. You can select the draft characters as the power-on default by turning DIP switch 1-2 on. This command is ignored when the “Print Quality Panel” mode is selected at power-on.

**NOTE:** The character “0” (decimal code 48, hexadecimal code 30) can be used instead of ASCII 0.

**SEE**                              Chapter 4



**■ Font pitch controls****PURPOSE**                      **Sets the print pitch to pica.**

<b>CODE</b>	⟨ESC⟩	“P”
(decimal ASCII)	27	80
(hex ASCII)	1B	50

**REMARKS**                      This command causes printing to be done in pica pitch, with 136 characters per line. You can select the pica pitch as the power-on default by turning DIP switch 1-1 on. This command is ignored when the “Print Pitch Panel” mode is selected at power-on.

**SEE**                              Chapter 4

**PURPOSE**                      **Sets the print pitch to elite.**

<b>CODE</b>	⟨ESC⟩	“M”
(decimal ASCII)	27	77
(hex ASCII)	1B	4D

**REMARKS**                      This command causes printing to be done in elite pitch, with 163 characters per line. This command is ignored when the “Print Pitch Panel” mode is selected at power-on.

**SEE**                              Chapter 4

**PURPOSE**                    **Sets the printer to condensed print.**

**CODE**                        **<SI>**  
 (decimal ASCII)            **15**  
 (hex ASCII)                **0F**

**REMARKS**                This command causes printing to be done in condensed pitch, with 233 characters per line for pica condensed, and 272 characters per line for elite condensed (NLQ characters are not printed in condensed pitch). You can select the pica condensed pitch with the control panel, but you cannot select the elite condensed pitch manually. This command is ignored when the "Print Pitch Panel" mode is selected at power-on.

**SEE**                        Chapter 4

**PURPOSE**                    **Sets the printer to condensed print.**

**CODE**                        **<ESC>    <SI>**  
 (decimal ASCII)            **27        15**  
 (hex ASCII)                **1B        0F**

**REMARKS**                Same as <SI>, above.

**SEE**                        Chapter 4

**PURPOSE**                     **Cancels condensed print.**

**CODE**                        **<DC2>**  
 (decimal ASCII)            **18**  
 (hex ASCII)                **12**

**REMARKS**                This command cancels condensed printing and returns the printer to the normal print pitch. This command is ignored when the "Print Pitch Panel" mode is selected at power-on.

**SEE**                        Chapter 4

**PURPOSE**                   **Sets the printer to proportional print.**

<b>CODE</b>	<ESC>	“p”	1
(decimal ASCII)	27	112	1
(hex ASCII)	1B	70	01

**REMARKS**                   This command causes all subsequent characters to be printed with proportional spacing until proportional printing is cancelled. This command is ignored when the “Print Pitch Panel” mode is selected at power-on.

**NOTE:** The character “1” (decimal code 49, hexadecimal code 31) can be used instead of ASCII 1.

**SEE**                           Chapter 4

**PURPOSE**                    **Cancels proportional print.**

<b>CODE</b>	<ESC>	“p”	0
(decimal ASCII)	27	112	0
(hex ASCII)	1B	70	00

**REMARKS**                   This command cancels proportional printing and returns to “fixed pitch” printing. This command is ignored when the “Print Pitch Panel” mode is selected at power-on.

**NOTE:** The character “0” (decimal code 48, hexadecimal code 30) can be used instead of ASCII 0.

**SEE**                           Chapter 4

**PURPOSE**                      **Sets the printer to expanded print.**

<b>CODE</b>	⟨ESC⟩	“W”	1
(decimal ASCII)	27	87	1
(hex ASCII)	1B	57	01

**REMARKS**                      This command causes characters to be printed twice as wide as normal (half the current pitch) until expanded printing is cancelled.

**NOTE:** The character “1” (decimal code 49, hexadecimal code 31) can be used instead of ASCII 1.

**SEE**                              Chapter 4

**PURPOSE**                       **Cancels expanded print.**

<b>CODE</b>	⟨ESC⟩	“W”	0
(decimal ASCII)	27	87	0
(hex ASCII)	1B	57	00

**REMARKS**                      This command resets the character pitch to what it was before expanded printing was set.

**NOTE:** The character “0” (decimal code 48, hexadecimal code 30) can be used instead of ASCII 0.

**SEE**                              Chapter 4

**PURPOSE**                      **Sets the printer to expanded print for the remainder of the current line.**

<b>CODE</b>	⟨SO⟩
(decimal ASCII)	14
(hex ASCII)	0E

**REMARKS**                      This command causes characters to be printed twice as wide as normally until a carriage return is sent. It can also be cancelled with ⟨DC4⟩.

**SEE**                              Chapter 4

**PURPOSE**                   **Sets the printer to expanded print for the remainder of the current line.**

<b>CODE</b>	⟨ESC⟩	⟨SO⟩
(decimal ASCII)	27	14
(hex ASCII)	1B	0E

**REMARKS**                   Same as ⟨SO⟩, above.

**SEE**                         Chapter 4

**PURPOSE**                    **Cancels one line expanded print.**

<b>CODE</b>	⟨DC4⟩
(decimal ASCII)	20
(hex ASCII)	14

**REMARKS**                   This command cancels one line expanded print set with ⟨SO⟩ or ⟨ESC⟩ ⟨SO⟩.

**SEE**                         Chapter 4

■ Special print modes

**PURPOSE**                   **Sets the master print mode.**

<b>CODE</b>	⟨ESC⟩	“?”	<i>n</i>
(decimal ASCII)	27	33	<i>n</i>
(hex ASCII)	1B	21	<i>n</i>

**REMARKS**                   This is a powerful command that allows the user to set several printing characteristics at one time: print pitch, condensed print, expanded print, boldface, italics, underlining, or any combination of these, as determined by *n*, a number from 0 to 255. (See Table 4-10 for details.)

**SEE**                         Chapter 4

**PURPOSE**                    **Selects emphasized printing.**

**CODE**                        <ESC>    "E"  
(decimal ASCII)            27        69  
(hex ASCII)                1B        45

**REMARKS**                 This command causes characters to be printed in emphasized until cancelled.

**SEE**                        Chapter 4

**PURPOSE**                     **Cancels emphasized printing.**

**CODE**                        <ESC>    "F"  
(decimal ASCII)            27        70  
(hex ASCII)                1B        46

**REMARKS**                 This command cancels emphasized printing and returns the printer to normal printing.

**SEE**                        Chapter 4

**PURPOSE**                    **Selects boldface printing.**

**CODE**                        <ESC>    "G"  
(decimal ASCII)            27        71  
(hex ASCII)                1B        47

**REMARKS**                 This command causes characters to be printed in boldface until cancelled.

**SEE**                        Chapter 4

**PURPOSE**                     **Cancels boldface printing.**

**CODE**                        <ESC>    "H"  
(decimal ASCII)            27        72  
(hex ASCII)                1B        48

**REMARKS**                 This command turns off boldface printing and returns the printer to normal printing.

**SEE**                        Chapter 4

<b>PURPOSE</b>	<b>Selects underlining.</b>		
<b>CODE</b>	<ESC>	“—”	1
(decimal ASCII)	27	45	1
(hex ASCII)	1B	2D	01
<b>REMARKS</b>	This command underlines the following characters until cancelled. <b>NOTE:</b> The character “1” (decimal code 49, hexadecimal code 31) can be used instead of ASCII 1.		
<b>SEE</b>	Chapter 4		
<b>PURPOSE</b>	<b> Cancels underlining.</b>		
<b>CODE</b>	<ESC>	“—”	0
(decimal ASCII)	27	45	0
(hex ASCII)	1B	2D	00
<b>REMARKS</b>	This command stops underlining. <b>NOTE:</b> The character “0” (decimal code 48, hexadecimal code 30) can be used instead of ASCII 0.		
<b>SEE</b>	Chapter 4		
<b>PURPOSE</b>	<b>Selects superscripts.</b>		
<b>CODE</b>	<ESC>	“S”	0
(decimal ASCII)	27	83	0
(hex ASCII)	1B	53	00
<b>REMARKS</b>	This command raises the following characters and prints them as superscripts until cancelled. Superscripts are printed from left to right only and in boldface. <b>NOTE:</b> The character “0” (decimal code 48, hexadecimal code 30) can be used instead of ASCII 0.		
<b>SEE</b>	Chapter 4		

<b>PURPOSE</b>	<b>Selects subscripts.</b>		
<b>CODE</b>	<ESC>	“S”	1
(decimal ASCII)	27	83	1
(hex ASCII)	1B	53	01
<b>REMARKS</b>	This command lowers the following characters and prints them as subscripts until cancelled. All conditions applicable to superscripts also apply to subscripts. <b>NOTE:</b> The character “1” (decimal code 49, hexadecimal code 31) can be used instead of ASCII 1.		
<b>SEE</b>	Chapter 4		
<b>PURPOSE</b>	<b> Cancels a superscript or subscript.</b>		
<b>CODE</b>	<ESC>	“T”	
(decimal ASCII)	27	84	
(hex ASCII)	1B	54	
<b>REMARKS</b>	This command stops printing of superscripts or subscripts and returns to the normal printing previously set. It also cancels uni-directional printing and boldface, which are set automatically for superscripts and subscripts.		
<b>SEE</b>	Chapter 4		



## CONTROLLING THE VERTICAL PRINT POSITION

These commands are used to move the paper relative to the print head. By moving the paper up or down, the print head, in effect, moves the opposite direction (down or up) on the page.

### ■ Line feed and reverse line feed controls

**PURPOSE**                      **Advances the paper one line (line feed).**

**CODE**                              **<LF>**  
 (decimal ASCII)                  10  
 (hex ASCII)                      0A

**REMARKS**                      The actual distance advanced of the line feed is set through various codes (see below). When the DIP switch 1-8 is off, a line feed is automatically generated whenever the printer receives a carriage return.

**SEE**                                Chapter 5

**PURPOSE**                      **Reverses the paper one line .**

**CODE**                              **<ESC>**    **<LF>**  
 (decimal ASCII)                  27        10  
 (hex ASCII)                      1B        0A

**REMARKS**                      This command causes the printer to reverse the paper (in effect moving the print head up on the sheet) one line. The actual distance travelled is set through various codes (see below).

You cannot reverse the paper more than one inch when the optional automatic sheet feeder is installed.

**SEE**                                Chapter 5

**PURPOSE**                    **Sets line spacing to 1/8 inch.**

**CODE**                        <ESC>      "0"  
 (decimal ASCII)            27            48  
 (hex ASCII)                1B            30

**REMARKS**                This command sets the actual distance the paper advances or reverses during all subsequent line feeds to 1/8 inch.

**SEE**                        Chapter 5

**PURPOSE**                    **Sets line spacing to 7/72 inch.**

**CODE**                        <ESC>      "1"  
 (decimal ASCII)            27            49  
 (hex ASCII)                1B            31

**REMARKS**                This command sets the actual distance the paper advances or reverses during all subsequent line feeds to 7/72 inch.

**SEE**                        Chapter 5

**PURPOSE**                    **Sets line spacing to  $n/216$  inch.**

**CODE**                        <ESC>      "3"             $n$   
 (decimal ASCII)            27            51             $n$   
 (hex ASCII)                1B            33             $n$

**REMARKS**                This command sets the actual distance the paper advances or reverses during all subsequent line feeds to  $n/216$  inch. The value of  $n$  must be between 1 and 255.

**SEE**                        Chapter 5

---

PURPOSE	<b>Sets or Defines line spacing to <math>n/72</math> inch.</b>		
CODE	<ESC>	"A"	$n$
(decimal ASCII)	27	65	$n$
(hex ASCII)	1B	41	$n$
REMARKS	<p>This command works in two different functions depending on the setting of DIP switch 2-5. When the DIP switch 2-5 is set on, this command sets the actual distance the paper advances or reverses during all subsequent line feeds to <math>n/72</math> inch immediately.</p> <p>When the DIP switch 2-5 is set off, this command defines the actual distance the paper advances or reverses during all subsequent line feeds to <math>n/72</math> inch. This command must be used in conjunction with &lt;ESC&gt; "2" which activates the &lt;ESC&gt; "A" definition. The value of <math>n</math> must be between 1 and 255.</p>		
SEE	Chapter 5		

**PURPOSE**                      **Sets line spacing to 1/6 inch, or  
Uses  $\langle$ ESC $\rangle$  "A" definition.**

<b>CODE</b>	$\langle$ ESC $\rangle$	"2"
(decimal ASCII)	27	50
(hex ASCII)	1B	32

**REMARKS**                      This command works in two different functions depending on the setting of DIP switch 2-5. When the DIP switch 2-5 is set on, this command sets the actual distance the paper advances or reverses during all subsequent line feeds to 1/6 inch.

When the DIP switch 2-5 is set off, this command activates the line spacing defined in the  $\langle$ ESC $\rangle$  "A" command. If the  $\langle$ ESC $\rangle$  "A" command has not been defined, the line spacing is changed to 1/6 inch.

**SEE**                              Chapter 5

**PURPOSE**                      **Sends a one-time paper feed of  
 $n/216$  inch.**

<b>CODE</b>	$\langle$ ESC $\rangle$	"J"	$n$
(decimal ASCII)	27	74	$n$
(hex ASCII)	1B	4A	$n$

**REMARKS**                      This command causes the printer to advance the paper  $n/216$  inch. It does not change the current value of line spacing and it does not cause a carriage return. The value of  $n$  must be between 1 and 255.

**SEE**                              Chapter 5

**PURPOSE**                    **Sends a one-time reverse feed of  $n/216$  inch.**

CODE	<ESC>	“j”	$n$
(decimal ASCII)	27	106	$n$
(hex ASCII)	1B	6A	$n$

**REMARKS**                    This command causes the printer to reverse the paper  $n/216$  inch. It does not change the current value of line spacing and it does not cause a carriage return. The value of  $n$  must be between 0 and 255.

**SEE**                            Chapter 5

**PURPOSE**                    **Sets print position to  $n$  lines.**

CODE	<ESC>	“f”	1	$n$
(decimal ASCII)	27	102	1	$n$
(hex ASCII)	1B	66	01	$n$

**REMARKS**                    This command sets the next print position to the  $n$ th line from the top of the current page.

**NOTE:** The character “1” (decimal code 49, hexadecimal code 31) can be used instead of ASCII 1.

**SEE**                            Chapter 5

#### ■ Form feed and related commands

**PURPOSE**                    **Advances the paper to the top of the next page (form feed).**

CODE	<FF>
(decimal ASCII)	12
(hex ASCII)	0C

**REMARKS**                    The actual length of a page ejected by a form feed is set either by setting of the DIP switch 1-1 or through various codes (see below). This command works as the paper eject command when the optional automatic sheet feeder is installed.

**SEE**                            Chapter 5

**PURPOSE**                    **Reverses the paper to the top of the current page.**

<b>CODE</b>	⟨ESC⟩	⟨FF⟩
(decimal ASCII)	27	12
(hex ASCII)	1B	0C

**REMARKS**                    This command causes the printer to reverse the paper to the top of the current printing page (or form). This command is ignored when the optional automatic sheet feeder is installed.

**SEE**                            Chapter 5

**PURPOSE**                    **Sets page length to *n* inches.**

<b>CODE</b>	⟨ESC⟩	“C”	0	<i>n</i>
(decimal ASCII)	27	67	0	<i>n</i>
(hex ASCII)	1B	43	00	<i>n</i>

**REMARKS**                    This command sets the length of all subsequent pages to *n* inches. The value of *n* must be between 1 and 22. You can select a power-on default form length of 11 inches or 12 inches by setting DIP switch 1-1. This command is ignored when the optional automatic sheet feeder is installed.

**SEE**                            Chapter 5

**PURPOSE**                    **Sets page length to *n* lines.**

<b>CODE</b>	⟨ESC⟩	“C”	<i>n</i>
(decimal ASCII)	27	67	<i>n</i>
(hex ASCII)	1B	43	<i>n</i>

**REMARKS**                    This command sets the length of all subsequent pages to *n* lines. The value of *n* must be between 1 and 255. This command is ignored when the optional automatic sheet feeder is installed.

**SEE**                            Chapter 5

■ Top/Bottom margins and vertical tabs

**PURPOSE**                      **Sets the top margin.**

CODE	<ESC>	"r"	<i>n</i>
(decimal ASCII)	27	114	<i>n</i>
(hex ASCII)	1B	72	<i>n</i>

**REMARKS**                      This command sets the top margin to *n* lines. Printing begins on the (*n* + 1)th line on the page. This command is ignored when the optional automatic sheet feeder is installed. The value of *n* must be between 1 and 255.

**SEE**                              Chapter 5

**PURPOSE**                      **Sets the bottom margin.**

CODE	<ESC>	"N"	<i>n</i>
(decimal ASCII)	27	78	<i>n</i>
(hex ASCII)	1B	4E	<i>n</i>

**REMARKS**                      This command sets the bottom margin to *n* lines. The printer will generate a form feed whenever there are *n* lines left on the page. This command is ignored when the optional automatic sheet feeder is installed. The value of *n* must be between 1 and 127.

**SEE**                              Chapter 5

**PURPOSE**                       **Cancels top and bottom margins.**

CODE	<ESC>	"O"
(decimal ASCII)	27	79
(hex ASCII)	1B	4F

**REMARKS**                      This command cancels both the top margin and the bottom margin.

**SEE**                              Chapter 5

**PURPOSE**                    **Advances paper to the next vertical tab position.**

**CODE**                        <VT>  
 (decimal ASCII)            11  
 (hex ASCII)                0B

**REMARKS**                This command causes the paper to be advanced to the next vertical tab position, or the top of the next page, whichever is first. If the vertical tab positions are not set, this command works as a line feed command.

**SEE**                        Chapter 5

**PURPOSE**                    **Sets vertical tab positions.**

<b>CODE</b>	<ESC>	"B"	<i>n1 n2 n3 ...</i>	0
(decimal ASCII)	27	66	<i>n1 n2 n3 ...</i>	0
(hex ASCII)	1B	42	<i>n1 n2 n3 ...</i>	00

**REMARKS**                This command cancels all current vertical tab positions and sets those defined at lines *n1*, *n2*, *n3*, etc. The maximum number of vertical tab positions allowed is 16. The ASCII 0 character is used as a command terminator. Each vertical tab position must be specified in ascending order.

**SEE**                        Chapter 5

**PURPOSE**                    **Selects vertical channels.**

<b>CODE</b>	<ESC>	"f"	<i>n0</i>
(decimal ASCII)	27	47	<i>n0</i>
(hex ASCII)	1B	2F	<i>n0</i>

**REMARKS**                This command selects one of the multiple vertical channels determined by the value of *n0*. The value of *n0* must be between 0 and 7.

**SEE**                        Chapter 5



**PURPOSE**                      **Sets vertical tab positions in a channel.**

CODE	<ESC>	"b"	<i>n0</i>	<i>n1</i>	<i>n2</i>	<i>n3</i>	...	0
(decimal ASCII)	27	98	<i>n0</i>	<i>n1</i>	<i>n2</i>	<i>n3</i>	...	0
(hex ASCII)	1B	62	<i>n0</i>	<i>n1</i>	<i>n2</i>	<i>n3</i>	...	00

**REMARKS**                      This command cancels all current vertical tab positions in channel *n0* and sets those defined at lines *n1*, *n2*, *n3*, etc. The maximum number of vertical tab positions for each channel allowed is 16. The ASCII 0 character is used as a command terminator. Each vertical tab position must be specified in ascending order. The vertical channel *n0* must be between 0 and 7.

**SEE**                              Chapter 5

**PURPOSE**                      **Sets vertical tab positions every *n* lines.**

CODE	<ESC>	"e"	1	<i>n</i>
(decimal ASCII)	27	101	1	<i>n</i>
(hex ASCII)	1B	65	01	<i>n</i>

**REMARKS**                      This command cancels all current vertical tab positions and sets those every *n* lines.

**NOTE:** The character "1" (decimal code 49, hexadecimal code 31) can be used instead of ASCII 1.

**SEE**                              Chapter 5

## CONTROLLING THE HORIZONTAL PRINT POSITION

This section described commands that move the print head and restrict its printing range (such as setting margins and tabs).

**PURPOSE** Returns print head to the left margin (carriage return).

**CODE** <CR>  
 (decimal ASCII) 13  
 (hex ASCII) 0D

**REMARKS** This command returns the print head to the left margin. If DIP switch 1-8 has been set off, this command will also cause a line feed character to be generated after the carriage return, thereby advancing to the beginning of the next print line automatically.

**SEE** Chapter 5

**PURPOSE** Sets the left and right margins.

**CODE** <ESC> "X" *n1* *n2*  
 (decimal ASCII) 27 88 *n1* *n2*  
 (hex ASCII) 1B 58 *n1* *n2*

**REMARKS** This command sets the left margin to *n1* characters and the right margin to *n2*. The values of *n1* and *n2* must be between 1 and 255, and *n2* should be greater than *n1*. You can set the left and right margins manually on the control panel.

**NOTE:** Changing the print pitch after the margins have been set does not change the margins — they stay in exactly the same place on the page.

**SEE** Chapter 5

<b>PURPOSE</b>	<b>Sets the left margin.</b>		
<b>CODE</b>	<ESC>	"I"	<i>n</i>
(decimal ASCII)	27	108	<i>n</i>
(hex ASCII)	1B	6C	<i>n</i>
<b>REMARKS</b>	<p>This command sets the left margin to <i>n</i> characters. Each line will begin in the (<i>n</i> + 1)th character position from the left edge. The value of <i>n</i> must be between 0 and 255. You can set the left margin manually on the control panel.</p> <p><b>NOTE:</b> Changing the print pitch after the left margin has been set does not change the margin — it stays in exactly the same place on the page.</p>		
<b>SEE</b>	Chapter 5		

<b>PURPOSE</b>	<b>Sets the right margin.</b>		
<b>CODE</b>	<ESC>	"Q"	<i>n</i>
(decimal ASCII)	27	81	<i>n</i>
(hex ASCII)	1B	51	<i>n</i>
<b>REMARKS</b>	<p>This command sets the right margin to <i>n</i>, which is the last character position that will be printed in a line. After execution of this command, any attempt to print beyond print position <i>n</i> will cause the printer to automatically generate a carriage return and a line feed before printing the remainder of the line. The value of <i>n</i> must be between 2 and 255. You can set the right margin manually on the control panel.</p> <p><b>NOTE:</b> Changing the print pitch after the right margin has been set does not change the margin — it stays in exactly the same position on the page.</p>		
<b>SEE</b>	Chapter 5		

**PURPOSE** Moves the print head to the next horizontal tab position.

**CODE** <HT>  
 (decimal ASCII) 9  
 (hex ASCII) 09

**REMARKS** This command causes the print head to advance to the next horizontal tab position. The horizontal tab positions are set at power-on to print positions 8, 16, 24, etc. (to the maximum print position).

**SEE** Chapter 5

**PURPOSE** Sets horizontal tab positions.

<b>CODE</b>	<ESC>	"D"	<i>n1n2n3...</i>	0
(decimal ASCII)	27	68	<i>n1n2n3...</i>	0
(hex ASCII)	1B	44	<i>n1n2n3...</i>	00

**REMARKS** This command cancels all current horizontal tab positions and sets those defined at print positions *n1*, *n2*, *n3*, etc. The maximum number of horizontal tab positions allowed is 28. The ASCII 0 character is used as a command terminator. Each horizontal tab position must be specified in ascending order.

**SEE** Chapter 5

**PURPOSE** Sets horizontal tab positions every *n* characters.

<b>CODE</b>	<ESC>	"e"	0	<i>n</i>
(decimal ASCII)	27	101	0	<i>n</i>
(hex ASCII)	1B	65	00	<i>n</i>

**REMARKS** This command cancels all current horizontal tab positions and sets those every *n* characters  
**NOTE:** The character "0" (decimal code 48, hexadecimal code 30) can be used instead of ASCII 0.

**SEE** Chapter 5

**PURPOSE** Moves the print head to an absolute horizontal position.

<b>CODE</b>	<ESC>	“\$”	<i>n1</i>	<i>n2</i>
(decimal ASCII)	27	36	<i>n1</i>	<i>n2</i>
(hex ASCII)	1B	24	<i>n1</i>	<i>n2</i>

**REMARKS** This command causes the printer to move the print head to an absolute horizontal position. The position, in inches, is determined by the formula  $(n1 + n2 \times 256)/60$ . The maximum distance is 13.6 inches.

**SEE** Chapter 5

**PURPOSE** Moves the print head to a specified horizontal position.

<b>CODE</b>	<ESC>	“\”	<i>n1</i>	<i>n2</i>
(decimal ASCII)	27	92	<i>n1</i>	<i>n2</i>
(hex ASCII)	1B	5C	<i>n1</i>	<i>n2</i>

**REMARKS** This command causes the printer to move the print head to a specified horizontal position when the NLQ character mode is selected. It can move the print head either left or right. The distance, in inches, is determined by the formula  $(n1 + n2 \times 256)/120$ . To move to the left, add 64 to the calculated value of *n2*. The maximum distance is 13.6 inches. The command will be ignored if you try to move to a position outside the current margins.

**SEE** Chapter 5

**PURPOSE** Adds *n* dot spaces between characters.

CODE	<ESC>	"space"	<i>n</i>
(decimal ASCII)	27	32	<i>n</i>
(hex ASCII)	1B	20	<i>n</i>

**REMARKS** This command increases the space between characters by *n* dots when the DIP switch 2-5 is set on.

**SEE** Chapter 6

**PURPOSE** Sets the print position to *n* characters.

CODE	<ESC>	"f"	0	<i>n</i>
(decimal ASCII)	27	102	0	<i>n</i>
(hex ASCII)	1B	66	00	<i>n</i>

**REMARKS** This command sets the next print position to *n* columns from the left margin. The value of *n* must be between 0 and 127.

**NOTE:** The character "0" (decimal code 48, hexadecimal code 30) can be used instead of ASCII 0.

**SEE** Chapter 5

**PURPOSE** Sets alignment, or centering.

CODE	<ESC>	"a"	<i>n</i>
(decimal ASCII)	27	97	<i>n</i>
(hex ASCII)	1B	61	<i>n</i>

**REMARKS** This command causes the printer to format text as follows:

<i>n</i>	Text formatting
0	Left justified (ragged right margin)
1	Centered
2	Right justified

**SEE** Chapter 5

**DOWNLOAD CHARACTER COMMANDS**

PURPOSE	<b>Defines download characters into RAM.</b>			
CODE	<ESC>	"&"	0	<i>n1 n2 m0 m1 ... m11</i> [ <i>m12 ... m46</i> ]
(decimal ASCII)	27	38	0	<i>n1 n2 m0 m1 ... m11</i> [ <i>m12 ... m46</i> ]
(hex ASCII)	1B	26	00	<i>n1 n2 m0 m1 ... m11</i> [ <i>m12 ... m46</i> ]
REMARKS	<p>This command is used to define one or more user-defined characters and to store them into RAM for later use. RAM is cleared when the power is turned off. The values of <i>n1</i> and <i>n2</i> specify the range of positions in RAM that the characters are to occupy. Valid character positions are any number between 0 and 255 except the area of block graphics in the IBM mode. Following <i>n2</i> the printer expects character data bytes for each character to be defined. The first byte, <i>m0</i>, is the attribute byte, for it specifies whether the character is a descender (if the first bit is 0), and the proportional width of the draft character (starting and ending dot columns are defined by the low order seven bits). <i>m1</i> through <i>m11</i> determine which dots form the draft character. In the case of NLQ download characters, valid character positions are any number between 32 and 127, and <i>m1</i> through <i>m46</i> determine which dots form the character.</p> <p><b>NOTE:</b> This command is ignored when the DIP switch 2-1 is set on.</p>			
SEE	Chapter 7			





**DOT GRAPHICS COMMANDS**

**PURPOSE** Prints normal-density graphics.

<b>CODE</b>	<ESC>	"K"	<i>n1 n2 m1 m2 .....</i>
(decimal ASCII)	27	75	<i>n1 n2 m1 m2 .....</i>
(hex ASCII)	1B	4B	<i>n1 n2 m1 m2 .....</i>

**REMARKS** This command selects 60 dots-per-inch, column-scan, bit-image graphics mode. The values of *n1* and *n2* represent the number of graphics characters to be printed, where the total number of characters = *n2* times 256 + *n1*. The correct number of graphics data bytes (*m1*, *m2*, etc.) must follow *n2*. The ASCII values of these bytes determine which pins are fired for each character.

**SEE** Chapter 7

**PURPOSE** Prints double-density graphics.

<b>CODE</b>	<ESC>	"L"	<i>n1 n2 m1 m2 .....</i>
(decimal ASCII)	27	76	<i>n1 n2 m1 m2 .....</i>
(hex ASCII)	1B	4C	<i>n1 n2 m1 m2 .....</i>

**REMARKS** This command selects 120 dots-per-inch, column-scan, bit-image graphics mode. The values of *n1* and *n2* are the same as in normal-density graphics. The correct number of graphics data bytes (*m1*, *m2*, etc.) must follow *n2*. The ASCII values of these bytes determine which pins are fired for each character.

**SEE** Chapter 7

**PURPOSE**                    **Prints double-density graphics at double-speed.**

<b>CODE</b>	<ESC>	“Y”	<i>n1 n2 m1 m2 .....</i>
(decimal ASCII)	27	89	<i>n1 n2 m1 m2 .....</i>
(hex ASCII)	1B	59	<i>n1 n2 m1 m2 .....</i>

**REMARKS**                    This command selects 120 dots-per-inch, column-scan, bit-image graphics mode at double-speed. The values of *n1* and *n2* are the same as in normal-density graphics. The correct number of graphics data bytes (*m1*, *m2*, etc.) must follow *n2*. The ASCII values of these bytes determine which pins are fired for each character.

**SEE**                            Chapter 7

**PURPOSE**                    **Prints quadruple-density graphics.**

<b>CODE</b>	<ESC>	“Z”	<i>n1 n2 m1 m2 .....</i>
(decimal ASCII)	27	90	<i>n1 n2 m1 m2 .....</i>
(hex ASCII)	1B	5A	<i>n1 n2 m1 m2 .....</i>

**REMARKS**                    This command selects 240 dots-per-inch, column-scan, bit-image graphics mode. The values of *n1* and *n2* are the same as in normal-density graphics. The correct number of graphics data bytes (*m1*, *m2*, etc.) must follow *n2*. The ASCII values of these bytes determine which pins are fired for each character.

**SEE**                            Chapter 7

**PURPOSE****Selects graphics modes.****CODE**

(decimal ASCII)

(hex ASCII)

<ESC>	"*"	<i>n0 n1 n2 m1 m2 .....</i>
27	42	<i>n0 n1 n2 m1 m2 .....</i>
1B	2A	<i>n0 n1 n2 m1 m2 .....</i>

**REMARKS**

This command selects one seven possible graphics modes, depending on the value of *n0*. The values of *n1* and *n2* are the same as normal-density graphics mode. The correct number of graphics data bytes (*m1*, *m2*, etc.) must follow *n2*. The ASCII values of these bytes determine which pins are fired for each character. The value of *n0* and its related graphics modes are shown below.

*n* Graphics mode

- |   |  |
|---|--|
| 0 | Normal-density (60 dots per inch)                  |
| 1 | Double-density (120 dots per inch)                 |
| 2 | Double-density at double-speed (120 dots per inch) |
| 3 | Quadruple-density (240 dots per inch)              |
| 4 | Semi-double density (80 dots per inch)             |
| 5 | Plotter graphics (72 dots per inch)                |
| 6 | CRT graphics (90 dots per inch)                    |

**SEE**

Chapter 7

**PURPOSE****Selects 9-pin graphics.****CODE**

(decimal ASCII)

(hex ASCII)

<ESC> “ ^ ”	<i>n0 n1 n2 m1 m2 .....</i>
27 94	<i>n0 n1 n2 m1 m2 .....</i>
1B 5E	<i>n0 n1 n2 m1 m2 .....</i>

**REMARKS**

This command selects column-scan, 9-pin bit-image graphics mode. The value of *n0* determines the print density. The values of *n1* and *n2* are the same as normal-density graphics mode. The correct number of graphics data bytes (*m1*, *m2*, etc.) must follow *n2*. The ASCII values of these bytes determine which pins are fired for each character.

**SEE**

Chapter 7

**PURPOSE****Redefines the graphics mode.****CODE**

(decimal ASCII)

(hex ASCII)

<ESC> “?”	<i>n0 n1</i>
27 63	<i>n0 n1</i>
1B 3F	<i>n0 n1</i>

**REMARKS**

This command redefines one of the 4 alternate graphics commands — <ESC> “K”, <ESC> “L”, <ESC> “Y”, or <ESC> “Z” — as one of the seven graphics density numbers with the <ESC> “\*” command, where *n0* is “K”, “L”, “Y”, or “Z” and *n1* is 0, 1, 2, 3, 4, 5, or 6.

**SEE**

Chapter 7

**MACRO INSTRUCTION COMMANDS**

<b>PURPOSE</b>	<b>Defines macro instruction.</b>			
<b>CODE</b>	<ESC>	“+”	.....	<RS>
(decimal ASCII)	27	43	.....	30
(hex ASCII)	1B	2B	.....	1E
<b>REMARKS</b>	This command cancels any existing macro instruction, and replace it with the defined instruction. The maximum number of characters allowed in the macro instruction is 16. The <RS> character marks the end of the macro definition.			
<b>SEE</b>	Chapter 6			
<b>PURPOSE</b>	<b>Executes macro instruction.</b>			
<b>CODE</b>	<ESC>	“+”	1	
(decimal ASCII)	27	43	1	
(hex ASCII)	1B	2B	01	
<b>REMARKS</b>	This command executes a previously defined macro instruction.			
<b>SEE</b>	Chapter 6			

**OTHER COMMANDS**

**PURPOSE**                    **Sets the value of the eighth data bit to logical 1.**

<b>CODE</b>	⟨ESC⟩	“)”
(decimal ASCII)	27	62
(hex ASCII)	1B	3E

**REMARKS**                    This command forces the eighth data bit of each subsequent character sent to the printer to logical 1. This code allows users with a 7-bit interface to access those characters whose ASCII code is greater than 127. This code should not be used to transmit printer control codes.

**SEE**                            Chapter 6

**PURPOSE**                    **Sets the value of the eighth data bit to logical 0.**

<b>CODE</b>	⟨ESC⟩	“=”
(decimal ASCII)	27	61
(hex ASCII)	1B	3D

**REMARKS**                    This command forces the eighth data bit of each subsequent character sent to the printer to logical 0. This code should not be used to transmit printer control code.

**SEE**                            Chapter 6

**PURPOSE**                    **Accepts the value of the eighth data bit as is.**

<b>CODE</b>	<ESC>	"#"
(decimal ASCII)	27	35
(hex ASCII)	1B	23

**REMARKS**                    This command cancels either setting of the eighth data bit. The printer will use the value of the eighth data bit that is sent from the computer. This code allows users with a 7-bit interface to resume normal functions after accessing those characters whose ASCII code is greater than 127.

**SEE**                            Chapter 6

**PURPOSE**                    **Prints "slash zero".**

<b>CODE</b>	<ESC>	"~"	1
(decimal ASCII)	27	126	1
(hex ASCII)	1B	7E	01

**REMARKS**                    This command causes to print the zero character with a slash.  
**NOTE:** The character "1" (decimal code 49, hexadecimal code 31) can be used instead of ASCII 1.

**SEE**                            Chapter 6

**PURPOSE**                    **Prints "normal zero".**

<b>CODE</b>	<ESC>	"~"	0
(decimal ASCII)	27	126	0
(hex ASCII)	1B	7E	00

**REMARKS**                    This command cancels printing the slash zero and returns printing to the normal zero character.  
**NOTE:** The character "0" (decimal code 48, hexadecimal code 30) can be used instead of ASCII 0.

**SEE**                            Chapter 6

**PURPOSE** Moves the print head back one print position (backspace).

**CODE** <BS>  
(decimal ASCII) 8  
(hex ASCII) 08

**REMARKS** This command shifts the print head one column to the left. If the print head is at the left margin, the command is ignored. This command can be used to overstrike or combine characters.

**SEE** Chapter 6

**PURPOSE** Deletes the last character sent.

**CODE** <DEL>  
(decimal ASCII) 127  
(hex ASCII) 7F

**REMARKS** This command deletes the last character received. This command is ignored if the last character received has already been printed, or if the last character received was all or part of a function code.

**SEE** Chapter 6

**PURPOSE** Cancels a line.

**CODE** <CAN>  
(decimal ASCII) 24  
(hex ASCII) 18

**REMARKS** This command deletes the last line in the print buffer at the time the command is used.

**SEE** Chapter 6



---

<b>PURPOSE</b>	<b>Sets printer off line.</b>
<b>CODE</b>	⟨DC3⟩
(decimal ASCII)	19
(hex ASCII)	13
<b>REMARKS</b>	This command causes the printer to go off line, disregarding all subsequent characters and function codes, with the exception of ⟨DC1⟩, which will return the printer to the on line state. This is not the same as pushing the On Line key. When the On Line indicator is not lit the printer will not respond to ⟨DC1⟩.
<b>SEE</b>	Chapter 6
<b>PURPOSE</b>	<b>Sets printer on line.</b>
<b>CODE</b>	⟨DC1⟩
(decimal ASCII)	17
(hex ASCII)	11
<b>REMARKS</b>	This command resets the printer to the on line state, allowing it to receive and process all subsequent characters and function codes. This is not the same as pushing the On Line key. When the On Line indicator is not lit, the printer will not respond to ⟨DC1⟩.
<b>SEE</b>	Chapter 6
<b>PURPOSE</b>	<b>Sounds the printer bell.</b>
<b>CODE</b>	⟨BEL⟩
(decimal ASCII)	7
(hex ASCII)	07
<b>REMARKS</b>	This command causes the buzzer to sound for about a quarter of a second.
<b>SEE</b>	Chapter 6

**PURPOSE** **Disables paper-out detector.**

<b>CODE</b>	<ESC>	“8”
(decimal ASCII)	27	56
(hex ASCII)	1B	38

**REMARKS** This command causes the printer to disregard the signal sent by the paper-out detector. The paper-out signal normally sounds the printer bell and stops printing until paper is inserted and the printer is reset. DIP switch 1-5 can also set to disable the paper-out detector.

**SEE** Chapter 6

**PURPOSE** **Enables paper-out detector.**

<b>CODE</b>	<ESC>	“9”
(decimal ASCII)	27	57
(hex ASCII)	1B	39

**REMARKS** This command restores the function of the paper-out detector.

**SEE** Chapter 6

**PURPOSE** **Selects uni-directional printing.**

<b>CODE</b>	<ESC>	“U”	1
(decimal ASCII)	27	85	1
(hex ASCII)	1B	55	01

**REMARKS** This command causes all subsequent printing to be done in uni-directional printing. Uni-directional printing is useful in printing tables or charts, since it ensures that vertical columns of characters will be aligned.

**NOTE:** The character “1” (decimal code 49, hexadecimal code 31) can be used instead of ASCII 1.

**SEE** Chapter 6

---

<b>PURPOSE</b>	<b>Cancels uni-directional printing.</b>		
<b>CODE</b>	<b>&lt;ESC&gt;</b>	<b>“U”</b>	<b>0</b>
(decimal ASCII)	27	85	0
(hex ASCII)	1B	55	00
<b>REMARKS</b>	This command cancels uni-directional printing and returns to the standard bi-directional printing, which is considerably faster. <b>NOTE:</b> The character “0” (decimal code 48, hexadecimal code 30) can be used instead of ASCII 0.		
<b>SEE</b>	Chapter 6		
<b>PURPOSE</b>	<b>Selects one-line uni-directional printing.</b>		
<b>CODE</b>	<b>&lt;ESC&gt;</b>	<b>“&lt;”</b>	
(decimal ASCII)	27	60	
(hex ASCII)	1B	3C	
<b>REMARKS</b>	This command immediately returns the print head to the left margin. The remainder of the line is printed from left to right. Normal (bi-directional) printing resumes following a carriage return.		
<b>SEE</b>	Chapter 6		

**PURPOSE**                    **Enlarges characters in whole or in part; cancels same.**

CODE	⟨ESC⟩	“h”	<i>n</i>
(decimal ASCII)	27	104	<i>n</i>
(hex ASCII)	1B	68	<i>n</i>

**REMARKS**                    This special command enlarges characters following the command until the enlargement is cancelled. The values of *n* have the following effects:

<i>n</i>	Effect
0	Cancels enlargement
1	Double-high, double-wide
2	Quadruple-high, quadruple-wide
3	Double-high, double-wide (Lower half only)
4	Double-high, double-wide (Upper half only)
5	Quadruple-high, quadruple-wide (Lower half only)
6	Quadruple-high, quadruple-wide (Upper half only)

**SEE**                            Chapter 6

**PURPOSE**                    **Expands the printable area.**

CODE	⟨ESC⟩	“6”
(decimal ASCII)	27	54
(hex ASCII)	1B	36

**REMARKS**                    This command causes the printer to use the high-order control code area as a printable character area when the DIP switch 2-5 is set on.

**SEE**                            Chapter 6

**PURPOSE**                    **Cancels the expansion of printable area.**

<b>CODE</b>	<ESC>	"7"
(decimal ASCII)	27	55
(hex ASCII)	1B	37

**REMARKS**                    This command cancels the expansion of the printable character area and restores the high-order control code area when the DIP switch 2-5 is set on.

**SEE**                            Chapter 6

**PURPOSE**                    **Prints characters in the undefined control code area.**

<b>CODE</b>	<ESC>	"I"	1
(decimal ASCII)	27	73	1
(hex ASCII)	1B	49	01

**REMARKS**                    This command causes the printer to print characters in the undefined control code area.

**NOTE:** The character "1" (decimal code 49, hexadecimal code 31) can be used instead of ASCII 1.

**SEE**                            Chapter 6

**PURPOSE**                    **Selects undefined codes as control codes.**

<b>CODE</b>	<ESC>	"I"	0
(decimal ASCII)	27	73	0
(hex ASCII)	1B	49	00

**REMARKS**                    This command cancels to print the characters in the undefined control codes and restores them as the control codes.

**NOTE:** The character "0" (decimal code 48, hexadecimal code 30) can be used instead of ASCII 0.

**SEE**                            Chapter 6

**PURPOSE****Sets immediate print mode.**

CODE	<ESC>	“i”	1
(decimal ASCII)	27	105	1
(hex ASCII)	1B	69	01

**REMARKS**

This command selects the immediate print mode. In the immediate print mode the print head prints one character at a time, as you send it. The printer also moves the paper up so that you can see the current line and then down to continue printing. This kind of instant feedback can be especially helpful in telecommunications.

**NOTE:** The character “1” (decimal code 49, hexadecimal code 31) can be used instead of ASCII 1.

**SEE**

Chapter 6

**PURPOSE** **Cancels immediate print mode.**

CODE	<ESC>	“i”	0
(decimal ASCII)	27	105	0
(hex ASCII)	1B	69	00

**REMARKS**

This command cancels the immediate print mode and returns the normal print mode.

**NOTE:** The character “0” (decimal code 48, hexadecimal code 30) can be used instead of ASCII 0.

**SEE**

Chapter 6

**PURPOSE** **Resets the printer.**

<b>CODE</b>	<b>&lt;ESC&gt;</b>	<b>“@”</b>
(decimal ASCII)	27	64
(hex ASCII)	1B	40

**REMARKS** This command reinitializes the printer. The print buffer is cleared, and the form length, character set, bottom margin, and international character set are all reset to the values defined by their respective DIP switches. The main difference between the <ESC> “@” command and turning the printer off and back on again is that download characters and macro instructions are preserved with this command.

**SEE** Chapter 6

**PURPOSE** **Selects auto feed mode.**

<b>CODE</b>	<b>&lt;ESC&gt;</b>	<b>&lt;EM&gt;</b>	<b>4</b>
(decimal ASCII)	27	25	4
(hex ASCII)	1B	19	04

**REMARKS** This command causes the printer to select the auto sheet feeding mode. This command is ignored when the optional automatic sheet feeder is not mounted on the printer.

**SEE** Chapter 6

**PURPOSE** **Selects auto feed mode.**

<b>CODE</b>	<b>“(”</b>	<b>“(”</b>	<b>“4”</b>	<b>“)”</b>	<b>“)”</b>
(decimal ASCII)	40	40	52	41	41
(hex ASCII)	28	28	34	29	29

**REMARKS** Same as <ESC> <EM> 4, above.

**SEE** Chapter 6

**PURPOSE** **Cancels auto feed mode.**

<b>CODE</b>	<b>&lt;ESC&gt;</b>	<b>&lt;EM&gt;</b>	<b>0</b>
(decimal ASCII)	27	25	0
(hex ASCII)	1B	19	00

**REMARKS** This command causes the printer to cancel the auto sheet feeding mode. This command is ignored when the optional automatic sheet feeder is not mounted on the printer.

**SEE** Chapter 6

**PURPOSE** **Cancels auto feed mode.**

<b>CODE</b>	<b>“(</b>	<b>“(</b>	<b>“0”</b>	<b>“)”</b>	<b>“)”</b>
(decimal ASCII)	40	40	48	41	41
(hex ASCII)	28	28	30	29	29

**REMARKS** Same as <ESC> <EM> 0, above.

**SEE** Chapter 6

**PURPOSE** **Supplies paper .**

<b>CODE</b>	<b>&lt;ESC&gt;</b>	<b>&lt;EM&gt;</b>	<b>1</b>
(decimal ASCII)	27	25	1
(hex ASCII)	1B	19	01

**REMARKS** This command causes the printer to supply paper under non-auto sheet feeding mode. This command is ignored when the optional automatic sheet feeder is not mounted on the printer.

**SEE** Chapter 6

**PURPOSE** **Supplies paper.**

<b>CODE</b>	<b>“(</b>	<b>“(</b>	<b>“1”</b>	<b>“)”</b>	<b>“)”</b>
(decimal ASCII)	40	40	49	41	41
(hex ASCII)	28	28	31	29	29

**REMARKS** Same as <ESC> <EM> 1, above.

**SEE** Chapter 6



**PURPOSE** **Ejects paper.**

<b>CODE</b>	<b>&lt;ESC&gt;</b>	<b>&lt;EM&gt;</b>	<b>"R"</b>
(decimal ASCII)	27	25	82
(hex ASCII)	1B	19	52

**REMARKS** This command causes the printer to eject paper. This command is ignored when the optional automatic sheet feeder is not mounted on the printer.

**SEE** Chapter 6

**PURPOSE** **Ejects paper.**

<b>CODE</b>	<b>"("</b>	<b>"("</b>	<b>"R"</b>	<b>")"</b>	<b>")"</b>
(decimal ASCII)	40	40	82	41	41
(hex ASCII)	28	28	52	29	29

**REMARKS** Same as <ESC> <EM> "R", above.

**SEE** Chapter 6

**MEMO**

all-guides.com

---

---

# APPENDIX D

## COMMAND SUMMARY

### IN NUMERIC ORDER

---

---

<b>Control code</b>	<b>Function</b>
CHR\$(7)	Sounds the printer bell
CHR\$(8)	Moves the print head back one print position (backspace)
CHR\$(9)	Moves the print head to the next horizontal tab position
CHR\$(10)	Advances the paper one line (line feed)
CHR\$(11)	Advances paper to the next vertical tab position
CHR\$(12)	Advances the paper to the top of the next page (form feed)
CHR\$(13)	Returns print head to the left margin (carriage return)
CHR\$(14)	Sets the printer to expanded print for the remainder of the current line
CHR\$(15)	Sets the printer to condensed print
CHR\$(17)	Sets printer on line
CHR\$(18)	Cancels condensed print
CHR\$(19)	Sets printer off line
CHR\$(20)	Cancels one line expanded print
CHR\$(24)	Cancels a line
CHR\$(27)	Escape (indicated as <ESC> below)
CHR\$(127)	Deletes the last character sent
<ESC> CHR\$(10)	Reverses the paper one line
<ESC> CHR\$(12)	Reverses the paper to the top of the current page
<ESC> CHR\$(14)	Sets the printer to expanded print for the remainder of the current line
<ESC> CHR\$(15)	Sets the printer to condensed print
<ESC> CHR\$(25) CHR\$(0)	Cancels auto feed mode

⟨ESC⟩ CHR\$(25) CHR\$(4)	Selects auto feed mode
⟨ESC⟩ CHR\$(25) "R"	Ejects paper
⟨ESC⟩ CHR\$(32) <i>n</i>	Adds <i>n</i> dot spaces between characters
⟨ESC⟩ "!" <i>n</i>	Sets the master print mode
⟨ESC⟩ "#"	Accepts the value of the eighth data bit as is
⟨ESC⟩ "\$" <i>n1 n2</i>	Moves the print head to an absolute horizontal position
⟨ESC⟩ "%" 0	Cancels download character set
⟨ESC⟩ "%" 1	Selects download character set
⟨ESC⟩ "&" CHR\$(0) <i>n1 n2 m0 m1 ..... m11 [m12 .....m46]</i>	Defines download characters into RAM
⟨ESC⟩ "*" <i>n0 n1 n2 m1 m2 ...</i>	Selects graphics modes
⟨ESC⟩ "+" CHR\$(1)	Executes macro instruction
⟨ESC⟩ "+" ..... CHR\$(30)	Defines macro instruction
⟨ESC⟩ "-" 0	Cancels underlining
⟨ESC⟩ "-" 1	Selects underlining
⟨ESC⟩ "p" <i>n0</i>	Selects vertical channels
⟨ESC⟩ "0"	Sets line spacing to 1/8 inch
⟨ESC⟩ "1"	Sets line spacing to 7/72 inch
⟨ESC⟩ "2"	Sets line spacing to 1/6 inch, or Uses ⟨ESC⟩"A" definition
⟨ESC⟩ "3" <i>n</i>	Sets line spacing to <i>n</i> /216 inch
⟨ESC⟩ "4"	Selects italic characters
⟨ESC⟩ "5"	Cancels italic characters
⟨ESC⟩ "6"	Expands the printable area, or Selects character set #2
⟨ESC⟩ "7"	Cancels the expansion of printable area, or Selects character set #1
⟨ESC⟩ "8"	Disables paper-out detector
⟨ESC⟩ "9"	Enables paper-out detector
⟨ESC⟩ ":@" CHR\$(0) CHR\$(0) CHR\$(0)	Copies standard ROM font into RAM
⟨ESC⟩ "<"	Selects one-line uni-directional printing
⟨ESC⟩ "="	Sets the value of the eighth data bit to logical 0

⟨ESC⟩ “)”	Sets the value of the eighth data bit to logical 1
⟨ESC⟩ “?” <i>n0 n1</i>	Redefines the graphics mode
⟨ESC⟩ “@”	Resets the printer
⟨ESC⟩ “A” <i>n</i>	Sets or defines line spacing to <i>n/72</i> inch
⟨ESC⟩ “B” <i>n1 n2 n3 ... CHR\$(0)</i>	Sets vertical tab positions
⟨ESC⟩ “C” <i>CHR\$(0) n</i>	Sets page length to <i>n</i> inches
⟨ESC⟩ “C” <i>n</i>	Sets page length to <i>n</i> lines
⟨ESC⟩ “D” <i>n1 n2 n3 ... CHR\$(0)</i>	Sets horizontal tab positions
⟨ESC⟩ “E”	Selects emphasized printing
⟨ESC⟩ “F”	Cancelled emphasized printing
⟨ESC⟩ “G”	Selects boldface printing
⟨ESC⟩ “H”	Cancelled boldface printing
⟨ESC⟩ “I” 0	Selects undefined codes as control codes
⟨ESC⟩ “I” 1	Prints characters in the undefined control code area
⟨ESC⟩ “J” <i>n</i>	Sends a one-time paper feed of <i>n/216</i> inch
⟨ESC⟩ “K” <i>n1 n2 m1 m2 ...</i>	Prints normal-density graphics
⟨ESC⟩ “L” <i>n1 n2 m1 m2 ...</i>	Prints double-density graphics
⟨ESC⟩ “M”	Sets the print pitch to elite
⟨ESC⟩ “N” <i>n</i>	Sets the bottom margin
⟨ESC⟩ “O”	Cancelled the top and bottom margins
⟨ESC⟩ “P”	Sets the print pitch to pica
⟨ESC⟩ “Q” <i>n</i>	Sets the right margin
⟨ESC⟩ “R” <i>n</i>	Selects an international character set
⟨ESC⟩ “S” 0	Selects superscripts
⟨ESC⟩ “S” 1	Selects subscripts
⟨ESC⟩ “T”	Cancelled a superscript or subscript
⟨ESC⟩ “U” 0	Cancelled uni-directional printing
⟨ESC⟩ “U” 1	Selects uni-directional printing
⟨ESC⟩ “W” 0	Cancelled expanded print
⟨ESC⟩ “W” 1	Sets the printer to expanded print
⟨ESC⟩ “X” <i>n1 n2</i>	Sets the left and right margins
⟨ESC⟩ “Y” <i>n1 n2 m1 m2 ...</i>	Prints double-density graphics at double-speed

⟨ESC⟩ “Z” <i>n1 n2 m1 m2 ...</i>	Prints quadruple-density graphics
⟨ESC⟩ “\” <i>n1 n2</i>	Moves the print head to a specified horizontal position
⟨ESC⟩ “^” <i>n0 n1 n2 m1 m2 .....</i>	Selects 9-pin graphics
⟨ESC⟩ “a” <i>n</i>	Sets alignment or centering
⟨ESC⟩ “b” <i>n0 n1 n2 n3 ... CHR\$(0)</i>	Sets vertical tab positions in a channel
⟨ESC⟩ “e” <i>0 n</i>	Sets horizontal tab positions every <i>n</i> characters
⟨ESC⟩ “e” <i>1 n</i>	Sets vertical tab positions every <i>n</i> lines
⟨ESC⟩ “f” <i>0 n</i>	Sets the print position to <i>n</i> characters
⟨ESC⟩ “f” <i>1 n</i>	Sets print position to <i>n</i> lines
⟨ESC⟩ “h” <i>n</i>	Enlarges characters in whole or in part; cancels same
⟨ESC⟩ “i” <i>0</i>	Cancels immediate print mode
⟨ESC⟩ “i” <i>1</i>	Sets immediate print mode
⟨ESC⟩ “j” <i>n</i>	Sends a one-time reverse feed of <i>n/216</i> inch
⟨ESC⟩ “l” <i>n</i>	Sets the left margin
⟨ESC⟩ “p” <i>0</i>	Cancels proportional print
⟨ESC⟩ “p” <i>1</i>	Sets the printer to proportional print
⟨ESC⟩ “r” <i>n</i>	Sets the top margin
⟨ESC⟩ “x” <i>0</i>	Cancels NLQ characters
⟨ESC⟩ “x” <i>1</i>	Selects NLQ characters
⟨ESC⟩ “~” <i>0</i>	Prints “normal zero”
⟨ESC⟩ “~” <i>1</i>	Prints “slash zero”
“(0)”	Cancels auto feed mode
“(4)”	Selects auto feed mode
“(R)”	Ejects paper

---



---

# APPENDIX E

# TECHNICAL

# SPECIFICATIONS

---



---

**Printing**

Printing method	Serial impact dot matrix
Printing speed	120 characters per second (in Draft pica) 30 characters per second (in NLQ mode)
Print buffer	4 KB
Paper feed	2.7 inches/second (for form feeding) Tractor and Friction feed
Printing direction	Bi-directional, logic seeking Uni-directional in dot graphics modes
Character set	
Draft characters	96 standard ASCII characters 33 international characters [11 sets] 83 IBM special characters 50 IBM block graphics characters 96 italic ASCII characters 33 italic international characters [11 sets] 83 italic IBM special characters
NLQ characters	96 standard ASCII characters 33 international characters [11 sets] 83 IBM special characters 96 italic ASCII characters 33 italic international characters [11 sets] 83 italic IBM special characters
Other characters	128 downloadable characters
Character matrix	18 × 23 dots, NLQ characters 9 × 11 dots, Draft characters 12 × 11 dots, IBM block graphics characters 8 × 816 dots, Normal-density graphics 8 × 1632 dots, Double-density graphics 8 × 3264 dots, Quadruple-density graphics

	8 × 1088 dots, CRT graphics
	8 × 1224 dots, CRT type II graphics
	8 × 979 dots, Plotter graphics
Line spacing	1/6 inch standard
	1/8, $n/72$ or $n/216$ inch programmable
Column width	136, normal pica
	163, normal elite
	233, condensed pica
	272, condensed elite
	68, expanded pica
	81, expanded elite
	116, expanded condensed pica
	136, expanded condensed elite
	and Proportional spacing
Special features	Near Letter Quality
	Automatic single sheet insertion
	Short form tear-off
	Easy access format switches
	Self-test and hex dump
	Downloadable characters
	Ultra hi-resolution bit image graphics
	Vertical and horizontal tabs
	Skip over perforation
	15.5" carriage
	Automatic sheet feeder (option)

**Paper**

Single sheets	6 – 14.5 inches, wide
	0.07 – 0.10 mm, thickness
Sprocket-feed paper	4 – 15.5 inches, wide
	0.07 – 0.10 mm, one-part form thickness
	Max 0.28 mm, 3-part form thickness

**Printer**

Dimensions	Hight 105 mm (4.1 inches)
	Width 542 mm (21.3 inches)
	Depth 360 mm (14.1 inches)
Weight	10.7 Kg (23.6 pounds)
Power	120 VAC $\pm$ 10%, 60Hz.
	220 VAC $\pm$ 10%, 50/60Hz.
	240 VAC $\pm$ 10%, 50/60Hz.



---

Environment	Temperature: 5 to 40°C (40 to 104°F) Humidity: 10 to 80%, non condensing
Ribbon	Black cloth ribbon in special cartridge Ribbon life: 3 million draft characters
Print head life	100 million draft characters

***Parallel interface***

Interface	Centronic-compatible, 7 or 8 bit
Synchronization	By external supplied Strobe pulses
Handshaking	By ACK or BUSY signals
Logic level	TTL
Connector	57-30360 Amphenol

***Serial interface (option)***

Interface	Asynchronous RS-232C/20 mA current loop
Bit rate	150, 300, 600, 2400, 4800, 9600, 19200 baud
Word length	1 start bit 7 or 8 data bits Odd, even or no parity 1 or 2 stop bits
Handshaking	Serial BUSY, 1 byte mode Serial BUSY, 1 block mode ACK mode XON/XOFF mode

## MEMO

---

---

# APPENDIX F

# THE

# PARALLEL INTERFACE

---

---

This printer has a parallel interface to communicate with the computer. The operating specifications of the parallel interface are as follows:

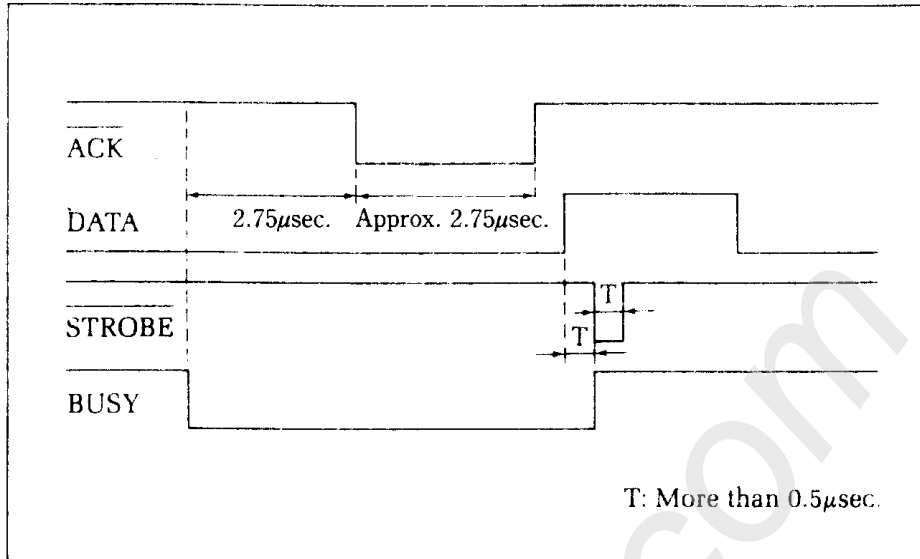
Data transfer rate:	1,000 to 6,000 characters per second
Synchronization:	Via externally supplied <u>STROBE</u> pulses
Handshaking:	ACK and BUSY signals
Logic level:	Compatible with TTL level

The parallel interface connects to the computer by a 36 pin connector on the back of the printer. This connector mates with an Amphenol 57-30360 connector. The functions of the various pins are summarized in Table F-1.

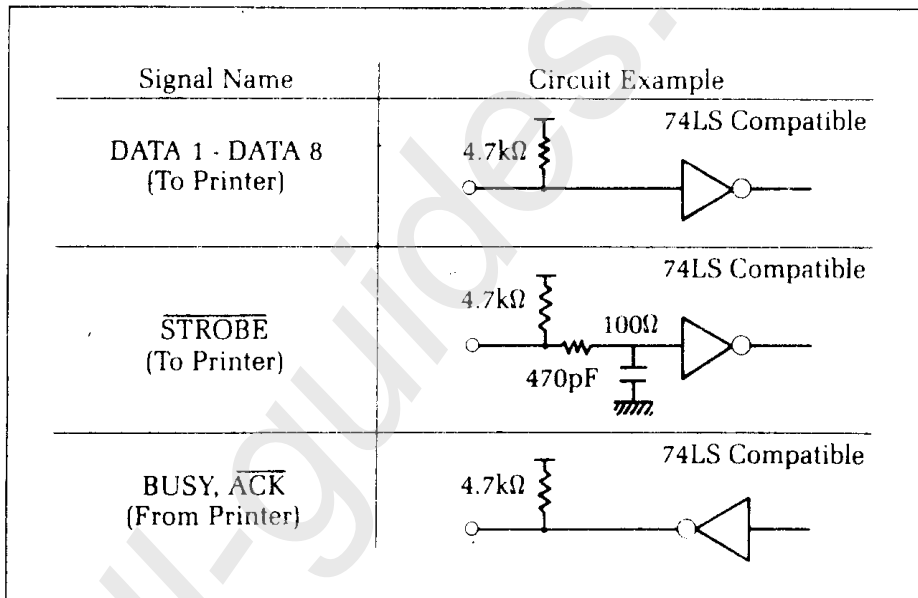
## ■ Functions of the Connector Signals

Communications between the computer and the printer use many of the pins of the connector. To understand how the system of communications works, let's look at the functions of the various signals carried by the pins of the interface connector.

Pin 1 carries the STROBE pulse signal from the computer to the printer. This signal is normally held high by the computer. When the computer has data ready for the printer it sets this signal to a low value for at least 0.5 microseconds. When the printer sees this pulse on the strobe pin, it reads the data that the computer supplies on pins 2 through 9. Each of these lines carries one bit of information. A logical "1" is represented by a high signal level, and a logical "0" is represented by a low signal level. The computer must maintain these signals for a period beginning at least 0.5 microseconds before the strobe pulse starts and continuing for at least 0.5 microseconds after the strobe pulse ends.



**Figure F-1.** The interface timing diagram.



**Figure F-2.** Typical interface circuit.

When the printer has successfully received the byte of data from the computer it sets pin 10 low for approximately 2.75 microseconds (15 microseconds when using the optional buffer board). This signal acknowledges the receipt of the data and so is called the  $\overline{\text{ACK}}$  (for "acknowledge") signal.

Pin 11 reports when the printer is not able to receive data. The signal is called BUSY. When this signal is high, the printer cannot receive data. This signal will be high during data transfer, when the printer is off-line and when an error condition exists.

The printer will report that it has run out of paper by making the PAPER OUT signal on pin 12 high. This pin can be held low by turning DIP switch 1-5 off. When the printer is in the on-line state, pin 13 is held high. This signal (SELECTED) tells the computer that the printer is ready to receive data.

**Table F-1**  
**Parallel interface pin functions**

Pin No.	Signal Name	Direction	Function
1	STROBE	IN	Signals when data is ready to be read. Signal goes from HIGH to LOW (for at least 0.5 microseconds) when data is available.
2	DATA1	IN	These signals provide the information of the first to eighth bits of parallel data. Each signal is at HIGH level for a logical 1 and at a LOW level for a logical 0.
3	DATA2	IN	
4	DATA3	IN	
5	DATA4	IN	
6	DATA5	IN	
7	DATA6	IN	
8	DATA7	IN	
9	DATA8	IN	
10	ACK	OUT	A LOW pulse acknowledges receipt of data.
11	BUSY	OUT	When this signal goes LOW the printer is ready to accept data.
12	PAPER OUT	OUT	This signal is normally LOW. It will go HIGH if the printer runs out of paper. This signal can be held LOW permanently by turning DIP switch 1-5 off.
13	SELECTED	OUT	This signal is HIGH when the printer is on-line.
14-15	N/C		Unused
16	SIGNAL GND		Signal ground.
17	CHASSIS GND		Printer's chassis ground, isolated from logic ground.
18	+ 5VDC	OUT	External supply of + 5VDC.
19-30	GND		Twisted pair return signal ground level.
31	RESET	IN	When this signal goes LOW the printer is reset to its power-on condition.
32	ERROR	OUT	This signal is normally HIGH. This signal goes LOW to signal that the printer cannot print due to an error condition.
33	EXT GND		External ground.
34, 35	N/C		Unused.
36	SELECT IN		Data entry to the printer is possible only when this level is LOW.

Pins 14, 15, 34 and 35 are not used, while pins 16, 17, 19-30 and 33 are grounded. Pin 18 is connected to the +5VDC supply in the printer.

Pin 31 can be used to reset the printer. If this signal ( $\overline{\text{RESET}}$ ) goes low the printer will reinitialize. Pin 32 is used to report error conditions in the printer. This signal ( $\overline{\text{ERROR}}$ ) is high during normal operation and goes low to report that the printer cannot print due to an error condition.

---

---

# APPENDIX G

## SERIAL INTERFACE

### SPECIFICATIONS

---

---

This printer provides a very flexible RS232C serial interface as an option. It can communicate at rates from 150 to 19,200 baud (bits per second) and supports four different kinds of *handshaking*. This interface can also function as a 20mA current loop interface. The operating specifications of the interface are as follows:

Data transfer rate:	150-19200
Word length:	1 start bit 7 or 8 data bits Odd, even or no parity 1 or 2 stop bits
Signal levels:	Mark or logical 1, -3 to -15 volts or current ON Space or logical 0, +3 to +15 volts or current OFF
Handshaking:	Serial BUSY, 1 byte mode Serial BUSY, 1 block mode ACK mode XON/XOFF mode

**Note:** 19200 baud can be used only with an RS232C interface; it cannot be used with a 20mA current loop interface.

The optional board has a DB-25 female connector to connect to a computer. The functions of the pins are summarized in Table G-1.

#### CONFIGURING THE SERIAL INTERFACE

The DIP switch on the serial interface board controls the configuration of the serial interface. Table G-2 describes the functions of the individual switches in DIP switch.

**Table G-1**  
**Serial interface pin functions**

Pin No.	Signal Name	Direction	Function
1	GND	—	Printer's chassis ground.
2	TXD	OUT	This pin carries data from the printer.
3	RXD	IN	This pin carries data to the printer.
4	RTS	OUT	This is ON when the printer is ready to receive data.
5	CTS	IN	This pin is ON when the computer is ready to send data.
6	DSR	IN	This pin is ON when the computer is ready to send data. This printer does not check this pin.
7	GND	—	Signal ground.
8	DCD	IN	This pin is ON when the computer is ready to send data. This printer does not check this pin.
9	TTY TXDR	—	This pin is the return path for data transmitted from the printer on the 20mA current loop.
10	TTY TXD	OUT	This pin carries data from the printer on the 20mA current loop.
11	RCH	OUT	This is the signal line for the serial busy protocols. This pin goes OFF when printer's buffer fills, and ON when the printer is ready to receive data. In the busy protocols this line carries the same signal as pin 20.
12	N/C		Unused.
13	GND	—	Signal ground.
14-16	N/C		Unused.
17	TTY TXDR	—	This pin is the return path for data transmitted from the printer on the 20mA current loop.
18	TTY RXDR	—	This pin is the return path for data transmitted to the printer on the 20mA current loop.
19	TTY RXD	IN	This pin carries data to the printer on the 20mA current loop.
20	DTR	OUT	The printer turns this pin ON when it is ready to receive data.
21-22	N/C		Unused.
23	TTY RXDR	—	This pin is the return path for data transmitted to the printer on the 20mA current loop.
24	TTY TXD	OUT	This pin carries data from the printer on the 20mA current loop.
25	TTY RXD	IN	This pin carries data to the printer on the 20mA current loop.



**Table G-2**  
**DIP switch on serial board**

Switch	ON	OFF
1	7 data bits	8 data bits
2	Parity checked	No parity
3	Handshaking protocols—see Table G-3	
4		
5	Odd parity	Even parity
6	Data transfer rate—see Table G-4	
7		
8		

**Table G-3**  
**Handshaking protocols**

Protocol	Switch 3	Switch 4
Serial busy, 1 byte mode	OFF	OFF
Serial busy, 1 block mode	ON	OFF
ACK mode	OFF	ON
XON/XOFF mode	ON	ON

**Table G-4**  
**Data transfer rates**

Baud rate	Switch 6	Switch 7	Switch 8
150	OFF	OFF	OFF
300	OFF	OFF	ON
600	OFF	ON	OFF
1200	OFF	ON	ON
2400	ON	OFF	OFF
4800	ON	OFF	ON
9600	ON	ON	OFF
19200	ON	ON	ON

## THE SERIAL PROTOCOLS

This printer has four serial protocols selected by DIP switches 3 and 4. Figure G-1 shows a typical byte of serial data and Figure G-2 shows timing charts for the 4 protocols.

### ■ Serial busy protocols

In the serial busy protocols, this printer uses DTR (pin 20) and RCH (pin 11) to signal to the computer when it is able to accept

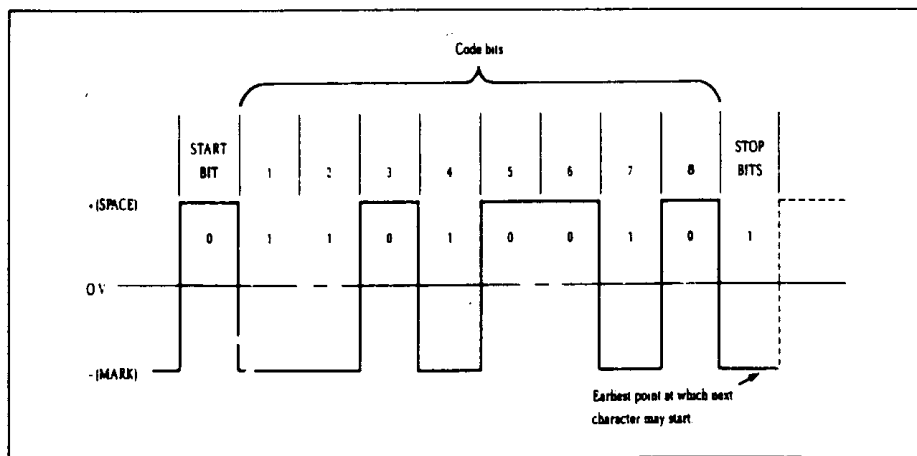
data. These two pins go ON when the printer is ready to accept data. In the 1 byte mode they go OFF after each character is received. In the 1 block mode they only go OFF when the printer's buffer approaches capacity. In both cases they will stay OFF if the buffer is too full to accept more data.

#### ■ XON/XOFF protocol

The XON/XOFF protocol uses the ASCII characters <DC1> and <DC3> (sometimes called XON and XOFF, respectively) to communicate with the computer. When the printer's buffer approaches capacity this printer will send a DC3 (ASCII 19) on TXD (pin 2) to tell the computer that it must stop sending data. When the printer is able to receive more data it sends a DC1 (ASCII 17) on TXD. The computer can then send more data until the printer sends another DC3.

#### ■ ACK protocol

In the ACK protocol, this printer sends an ACK (ASCII 6) on TXD (pin 2) each time that it is prepared to receive a byte of data.



**Figure G-1.** Typical data byte on the serial interface.

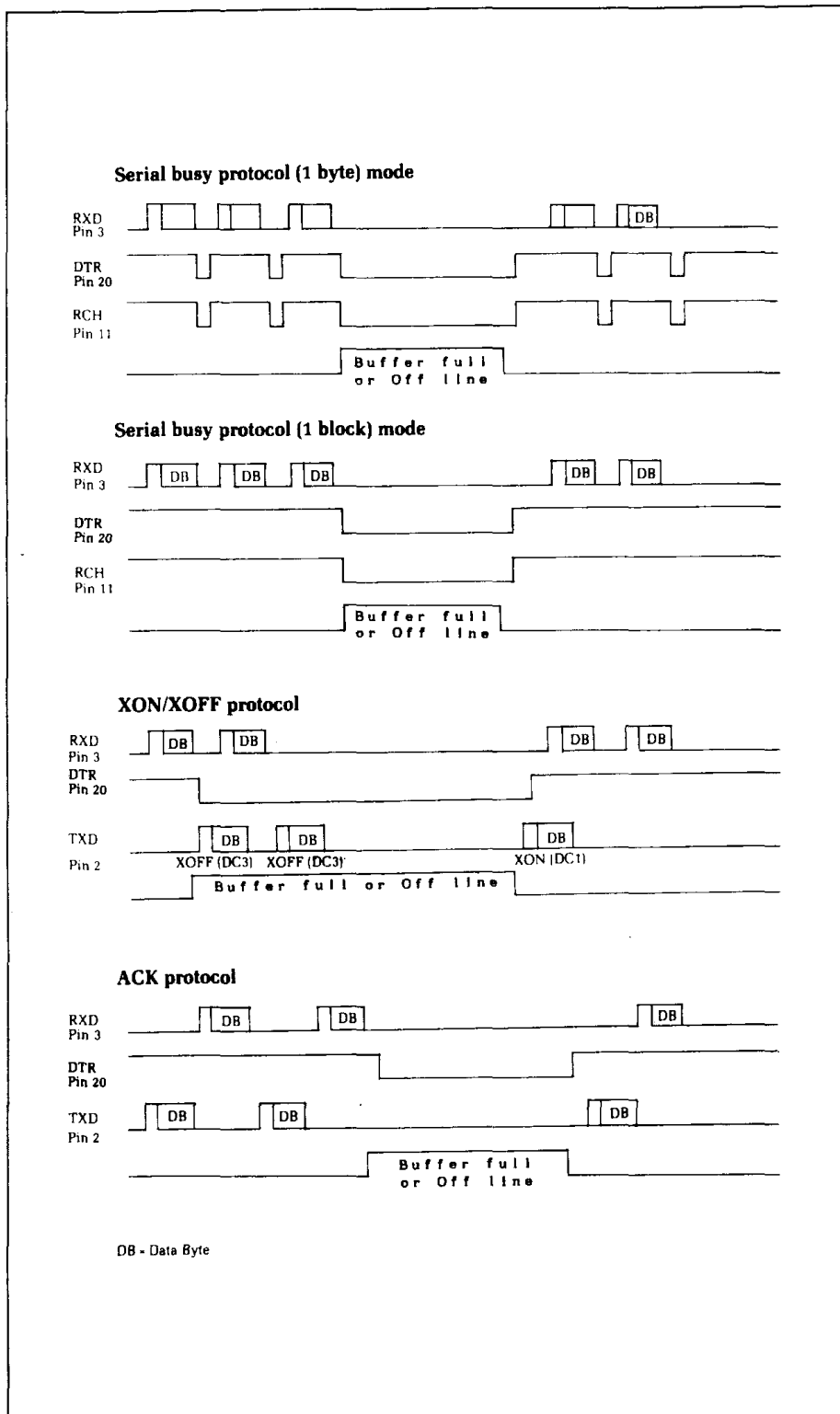


Figure G-2. Serial protocol timing charts.

# INDEX

- 9-pin graphics, *112, 164*
- Absolute tab, *69, 157*
- ACK protocol, *194*
- Adjusting paper gap, *16*
- Adjusting width of space, *81*
- Advance paper, *55, 145, 146, 147, 148, 149*
- Aligning text, *74, 158*
- Alternate graphics codes, *111*
- American Standard Code for Information Interchange, *39*
- ASCII code conversion chart, *125*
- ASCII codes, *39, 94*
- Attribute byte, *99*
- Auto feed mode, *175*
- Automatic sheet feeder, *92, 175*
  
- Backspace, *79, 168*
- BASIC, *37, 38*
- <BEL>, *77, 169*
- Bell, *77, 169*
- Bi-directional print, *82, 171*
- Big characters, *90, 172*
- Bit image graphics, *108*
- Block graphics, *84*
- Boldface print, *28, 31, 51, 53, 142*
- Bottom margin, *122, 151*
- <BS>, *79, 168*
  
- <CAN>, *79, 168*
- Cancel, auto feed mode, *176*
  - boldface print, *51, 142*
  - emphasized print, *51, 142*
  - expanded print, *47, 140*
  - italics, *43, 134*
  - margins, *63, 151*
  - NLQ, *43, 136*
  - proportional print, *50, 139*
  - superscripts and subscripts, *45, 144*
  - text, *79, 168*
  - underlining, *44, 143*
- Carriage return, *55, 154*
- Centering text, *74, 158*
- Changing line spacing, *56, 146*
  - page length, *62, 150*
- Channels, vertical tab, *73, 153*
- Character graphics, *84*
- Character set #1, *84, 122, 135*
- Character set #2, *84, 122, 135*
- Character space, *158*
- Character width, *26, 46*
- Characters in the control code area, *88*
- Chart, ASCII code, *125*
- Chart, character set #2, *85*
- CHR\$ function, *38*
- CHR\$(7), *169*
- CHR\$(8), *168*
- CHR\$(9), *67, 156*
- CHR\$(10), *55, 145*
- CHR\$(11), *70, 152*
- CHR\$(12), *61, 149*
- CHR\$(13), *55, 154*
- CHR\$(14), *47, 140*
- CHR\$(15), *49, 138*
- CHR\$(17), *78, 169*
- CHR\$(18), *49, 138*
- CHR\$(19), *78, 169*
- CHR\$(20), *47, 141*
- CHR\$(24), *79, 168*
- CHR\$(127), *79, 168*
- Clamp lever, *11, 14*
- Cleaning, *115*
- Clearing margins, *63*
- Combining print modes, *53*
- Command syntax, *41*
- Commands, dot graphics, *161*
  - download characters, *159*
  - font pitch, *137*
  - font style, *133*
  - form feed, *149*
  - horizontal position, *154*
  - line feed, *145*
  - macro instruction, *165*
  - print style, *133*
  - vertical position, *145*
- Commercial software, *21*
- Computer paper, *13*
- Condensed pitch, *26, 33, 48, 53, 138*
- Connecting the printer, *18*
- Control code area, *88*
- Control codes, *39*
- Control key, *39*
- Control panel, *9*
- Copying characters to download RAM, *102, 160*
- Cord, power, *7*
- Cover open detector, *5*
- Cover, printer, *2, 7, 12*
- Covers, sprocket, *14*
- <CR>, *55, 154*
  
- <DC1>, *78, 169*
- <DC2>, *138*
- <DC3>, *78, 169*
- <DC4>, *141*

- Defining characters, 98, 159
  - macro instruction, 93, 165
- <DEL>, 79, 168
- Delete, 79, 168
- Deselect printer, 78, 170
- Detector, cover open, 5
  - paper-out, 78, 169
- DIP switches, 10, 24, 56, 58, 81, 84, 92, 121, 134, 145, 147, 149, 154, 158, 170, 172, 175, 191
- Dot graphics, 108, 163
- Dot graphics commands, 161
- Dot matrix, 97
- Double density graphics, 110, 111, 161
- Double-strike, 31
- Download characters, 78, 97, 122, 159, 175
- Draft characters, 122
- Draft indicator, 9
  
- EasyWriter II, 22, 25
- Eighth bit controls, 83, 166, 167
- Ejects paper, 177
- Elite pitch, 26, 33, 46, 53, 137
- Emphasized printing, 28, 51, 53, 142
- Enlarged characters, 90, 172
- Environment, 1
- Escape code, 23, 31, 40
  - <ESC> "!" n, 141
  - <ESC> "#", 83, 167
  - <ESC> "\$", 157
  - <ESC> "%" n, 102, 160
  - <ESC> "&" CHR\$(0), 101, 159
  - <ESC> "\*" n, 109, 163
  - <ESC> "+", 93, 165
  - <ESC> "-" 0, 44, 143
  - <ESC> "-" 1, 44, 143
  - <ESC> "/", 73, 152
  - <ESC> "0", 59, 146
  - <ESC> "1", 59, 146
  - <ESC> "2", 58, 148
  - <ESC> "3" n, 58, 146
  - <ESC> "4", 43, 133
  - <ESC> "5", 43, 134
  - <ESC> "6", 84, 88, 135, 172
  - <ESC> "7", 84, 88, 135, 173
  - <ESC> "8", 170
  - <ESC> "9", 170
  - <ESC> ":", 102, 160
  - <ESC> "<", 82, 171
  - <ESC> "=", 84, 166
  - <ESC> ">", 84, 166
  - <ESC> "?", 111, 164
  - <ESC> "@", 23, 78, 175
  - <ESC> "A" n, 58, 147
  - <ESC> "a" n, 75, 158
  - <ESC> "B", 71, 152
  - <ESC> "b", 73, 153
  - <ESC> "C", 62, 150
  - <ESC> CHR\$(14), 47
  - <ESC> CHR\$(15), 49
  - <ESC> CHR\$(32), 158
  - <ESC> "D", 68, 156
  - <ESC> "E", 51, 142
  - <ESC> "e0", 156
  - <ESC> "e1", 153
  - <ESC> <EM> 0, 92, 176
  - <ESC> <EM> 1, 92, 176
  - <ESC> <EM> 4, 92, 175
  - <ESC> <EM> "R", 92, 177
  - <ESC> "F", 51, 142
  - <ESC> "f0", 158
  - <ESC> "f1", 149
  - <ESC> <FF>, 61, 150
  - <ESC> "G", 51, 142
  - <ESC> "H", 51, 142
  - <ESC> "h" n, 90, 172
  - <ESC> "I" n, 89, 173
  - <ESC> "i" n, 81, 174
  - <ESC> "J" n, 59, 148
  - <ESC> "j" n, 59, 148
  - <ESC> "K", 111, 161
  - <ESC> "L", 111, 161
  - <ESC> <LF>, 56, 145
  - <ESC> "l" n, 66, 155
  - <ESC> "M", 46, 137
  - <ESC> "N" n, 63, 151
  - <ESC> "O", 63, 151
  - <ESC> "P", 46, 137
  - <ESC> "p" 0, 50, 139
  - <ESC> "p" 1, 50, 139
  - <ESC> "Q" n, 66, 155
  - <ESC> "R" n, 134
  - <ESC> "r" n, 63, 151
  - <ESC> "S" 0, 45, 143
  - <ESC> "S" 1, 45, 144
  - <ESC> <SI>, 138
  - <ESC> <SO>, 141
  - <ESC> "T", 45, 144
  - <ESC> "U" n, 82, 170
  - <ESC> "W" n, 48, 140
  - <ESC> "X" n1 n2, 66, 154
  - <ESC> "x" 0, 24, 43, 136
  - <ESC> "x" 1, 24, 43, 136
  - <ESC> "Y", 111, 162
  - <ESC> "Z", 111, 162
  - <ESC> "\", 157
  - <ESC> "~", 111, 164
  - <ESC> "~" n, 167
- Execute macro instruction, 165

- Expanded print, 27, 33, 47, 53, 140
- Extra functions, 10, 33
- Feeding paper, 10, 13
  - <FF>, 61, 149
- Font pitch commands, 137
- Font style commands, 133
- Foreign language characters, 87, 122, 134
- Form feed, 61, 149
- Form feed commands, 149
- Form feed, reverse, 61
- Forward micro-feed, 35
- Gap, adjusting, 16
- Graphics, 84
  - CRT, 110, 111
  - CRT type II, 110, 111
  - data, 109
  - double density, 110, 111
  - normal density, 110, 111
  - plotter, 110, 111
  - quadruple density, 110, 111
- Grid for download characters, 100, 105
- Hex dump, 94
- Hexadecimal, 39, 95
- High resolution graphics, 110
- Horizontal position commands, 154
- Horizontal tabs, 67, 156, 157
  - <HT>, 67, 156
- IBM mode, 42, 58, 84, 122, 135, 135, 147
- Immediate print, 80, 174, 175
- Indicator, draft, 9
  - mode, 9
  - NLQ, 9
  - on line, 9, 169
  - paper empty, 9
  - pitch, 9
  - power, 9
- Initialize printer, 23, 26, 78, 175
- Ink ribbon cartridge, 4, 115
- Installation programs, 21
- Interface board, 2, 5, 8
- Interface, parallel, 187
  - serial, 191
- International characters, 87, 122, 134
- Italic panel mode, 34
- Italics, 28, 43, 53, 133
- Key, mode, 9, 34, 94
  - on line, 9, 18, 169
  - paper feed, 9, 18, 94
  - print pitch, 9, 34
  - TOF, 9, 34
- Left and right margins, 35
- Lever, clamp, 12, 14
  - release, 10, 11, 14
- <LF>, 55, 145
- Line feed, 55, 145, 148
- Line feed commands, 145
- Line feed, reverse, 56, 145
- Line spacing, 56, 147, 148
- Listing programs, 38
- LLIST, 38
- Loading paper, 10, 11, 13
- Location, 1
- Lotus 1-2-3, 22, 31
- LPRINT, 38
- Macro instruction, 78, 93, 165
- Macro instruction commands, 165
- Maintenance, 115
- Margins, left and right, 35, 66, 154
  - top and bottom, 63, 92, 151
- Master print mode, 141
- Master reset code, 23, 26, 78, 175
- Micro-feed, forward, 35
  - reverse, 35
- Mixing print modes, 53
- Mode indicators, 9
- Mode key, 9, 34, 94
- NLQ characters, 122
- NLQ download characters, 104
- NLQ indicator, 9
- Near Letter Quality (NLQ) characters, 24, 26, 33, 42, 136
- Normal density graphics, 110, 111, 161
- Normal zero, 80, 167
- Off line, 78, 169
- On line, 78
- On line indicator, 9
- On line key, 9, 18, 169
- One line expanded print, 48, 140
- One-time tab, 68
- One-time uni-directional print, 82, 171
- Packing tube, 3
- Page length, 62, 92, 122
- Panel mode, 33, 78
  - italic, 34
  - print pitch, 34
  - print quality, 34, 136
- Paper bail, 10, 12
- Paper empty indicator, 9
- Paper feed key, 9, 18, 94
- Paper feeding, 10, 13
- Paper gap, adjusting, 16

- Paper separator, 7, 14
- Paper thickness, adjustment, 16
- Paper-out, 122
- Paper-out detector, 78
- Parallel interface, 187
- Pica pitch, 26, 33, 46, 137
- Pitch, 26, 46, 137
- Pitch indicators, 9
- Platen, 7
- Platen knob, 10
- Plotter graphics, 110, 111
- Power cord, 7
- Power indicator, 9
- Power switch, 10
- Print head, 7, 118
- Print pitch, 26
- Print pitch key, 9, 34
- Print pitch panel mode, 34
- Print position, 149, 157
- Print quality panel mode, 34, 136
- Print start position, 35
- Print style commands, 133
- Printable area, 172
- Printer cover, 2, 7, 12
- Printer initialization, 23, 26, 78, 175
- Printing download characters, 102, 106, 160
- Programs, listing, 38
- Proportional print, 33, 50, 53, 139
- Protective tube, 3
  
- Quadruple density graphics, 110, 111, 162
  
- RAM characters, 98
- Redefine dot graphics, 164
- Relative tab, 69, 157
- Release lever, 10, 11, 14
- Reset code, 23, 26, 78, 175
- Reverse form feed, 61, 150
- Reverse line feed, 56, 145
- Reverse micro-feed, 35
- Reverse paper, 56, 61, 145, 149, 150
- Ribbon cartridge, 4, 115
- ROM characters, 98
  
- Select printer, 169
- Self-test, 17
- Serial busy protocol, 193
- Serial interface, 191
- Setting margins, 63, 66, 151, 154
- Setting tabs, 67, 71, 156
- Setup, 1
- Seven bit interface, 83, 166
- Sheet feeder, 92
  
- <SI>, 138
- Single sheets, 11
- Skip over perforation, 63
- Slash zero, 80, 167
- <SO>, 140
- Software mode, 41
- Software, commercial, 21
- Space, adjusting, 81
  - character, 158
- Special symbols, 84
- Specifications, 183
- Sprocket covers, 14
- Sprocket feed paper, 7, 13
- Standard mode, 42, 81, 122, 147, 158, 172, 173
- Starting new line, 55
- Subscripts, 28, 31, 45, 144
- Superscripts, 28, 31, 45, 143
- Switch, power, 10
- Switches, DIP, 10, 24, 56, 58, 81, 84, 92, 121, 147, 150, 154, 170, 191
- Syntax, command, 41
  
- Tab channel, 73
- Tab, absolute, 69, 157
  - relative, 69, 157
- Tabs, horizontal, 67, 156, 157
  - vertical, 70, 92, 152
- Testing printer, 17
- Thickness, adjusting gap, 16
- TOF key, 9, 34
- Top and bottom margins, 92
- Tractor feed unit, 7
  
- Underlining, 28, 31, 44, 53, 143
- Uni-directional print, 82, 170
- Unpacking, 1
- User-defined characters, 78, 97
  
- Vertical channels, 153
- Vertical positions commands, 145
- Vertical tab channels, 73
- Vertical tabs, 70, 92, 152
- <VT>, 70, 152
  
- Word processing, 22
- WordStar, 22, 30
  
- XON/XOFF protocol, 194
  
- Zero, normal, 80, 167
  - slash, 80, 167



## ***Consumer Response***

Star Micronics Co., Ltd. invites your suggestions and comments on your printer and this manual. Please address your correspondence to:

*Worldwide Headquarters:*

STAR MICRONICS CO., LTD.  
194 Nakayoshida  
Shizuoka, JAPAN 422-91  
Attn: Product Manager

*American Market:*

STAR MICRONICS AMERICA INC.  
Pan Am Bldg., Suite 3510  
200 Park Avenue  
New York, NY 10166  
Attn: Product Manager

*European Market:*

STAR MICRONICS DEUTSCHLAND GMBH  
Mergenthalerallee 1-3.  
D-6236 Eschborn/Ts., WEST GERMANY  
Attn: Product Manager

*U.K Market:*

STAR MICRONICS U.K., LTD.  
Craven House, 4th Floor  
40 Uxbridge Road, Ealing W-5 2BS London, ENGLAND  
Attn: Product Manager

*Asian Market:*

STAR MICRONICS (S.E.A.) LTD.  
Room 2409-10, Sincere Building  
173 Des Voeux Road Central, HONG KONG  
Attn: Product Manager





PRINTED IN JAPAN